

CONJUNTO PUERTA
(Esc. 1:1)

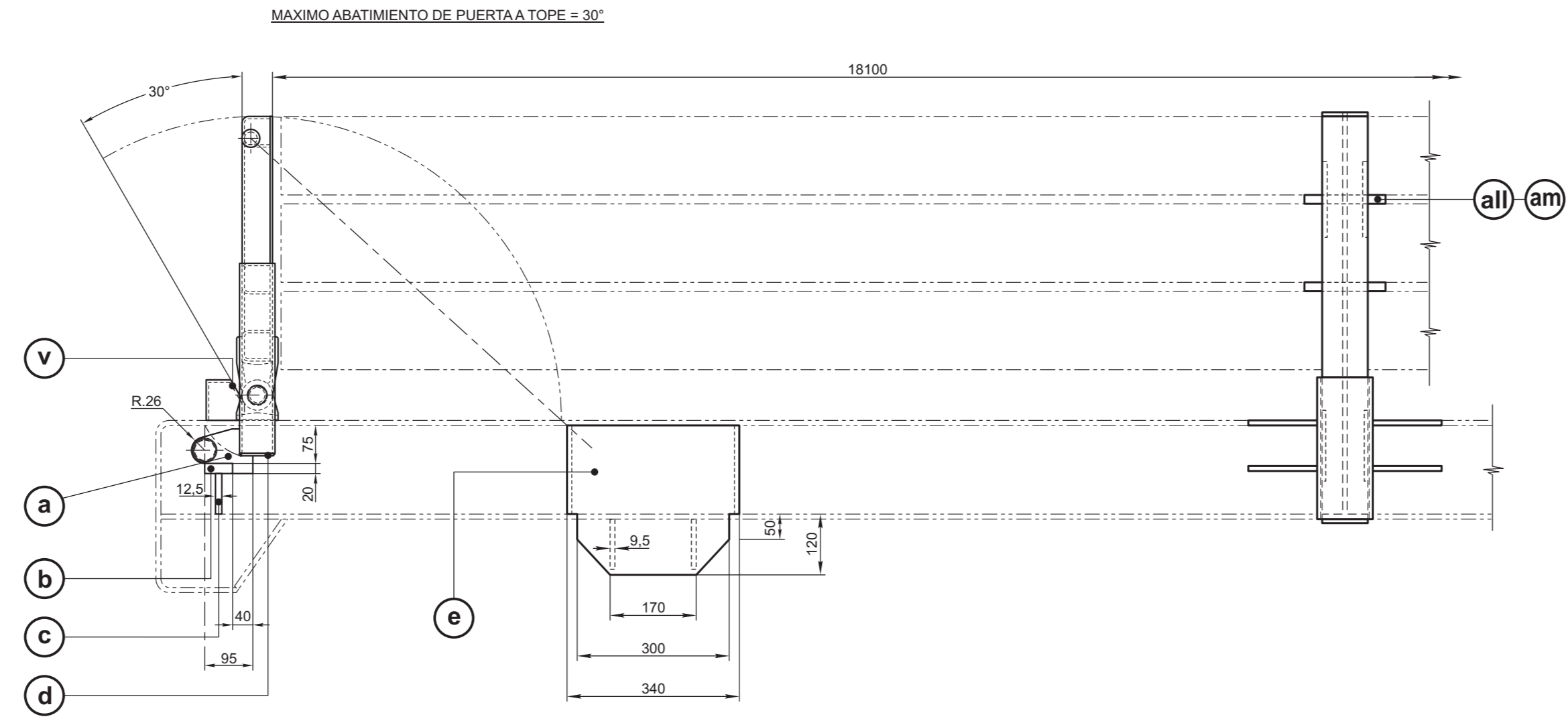

Esc. 1:10

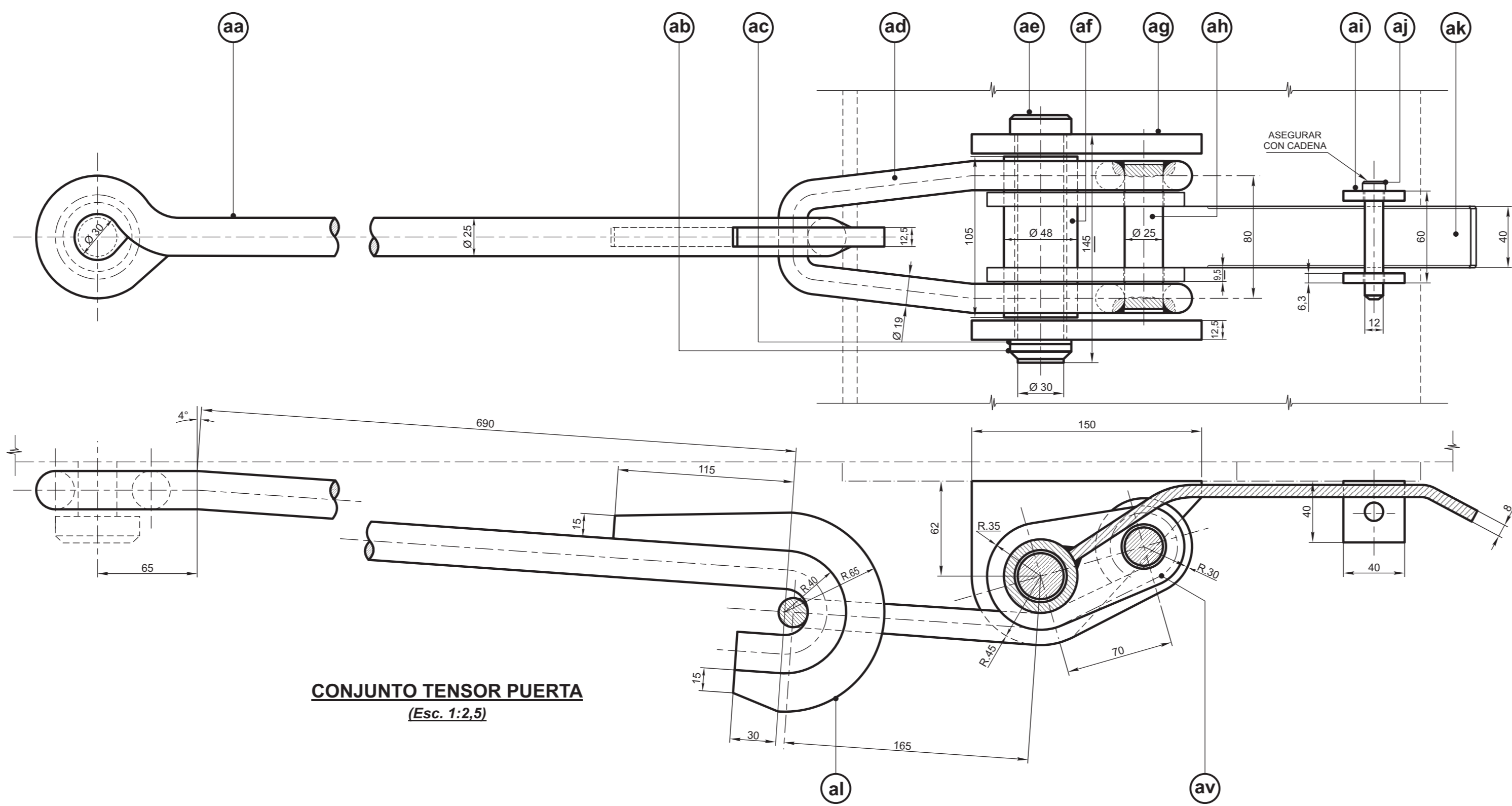
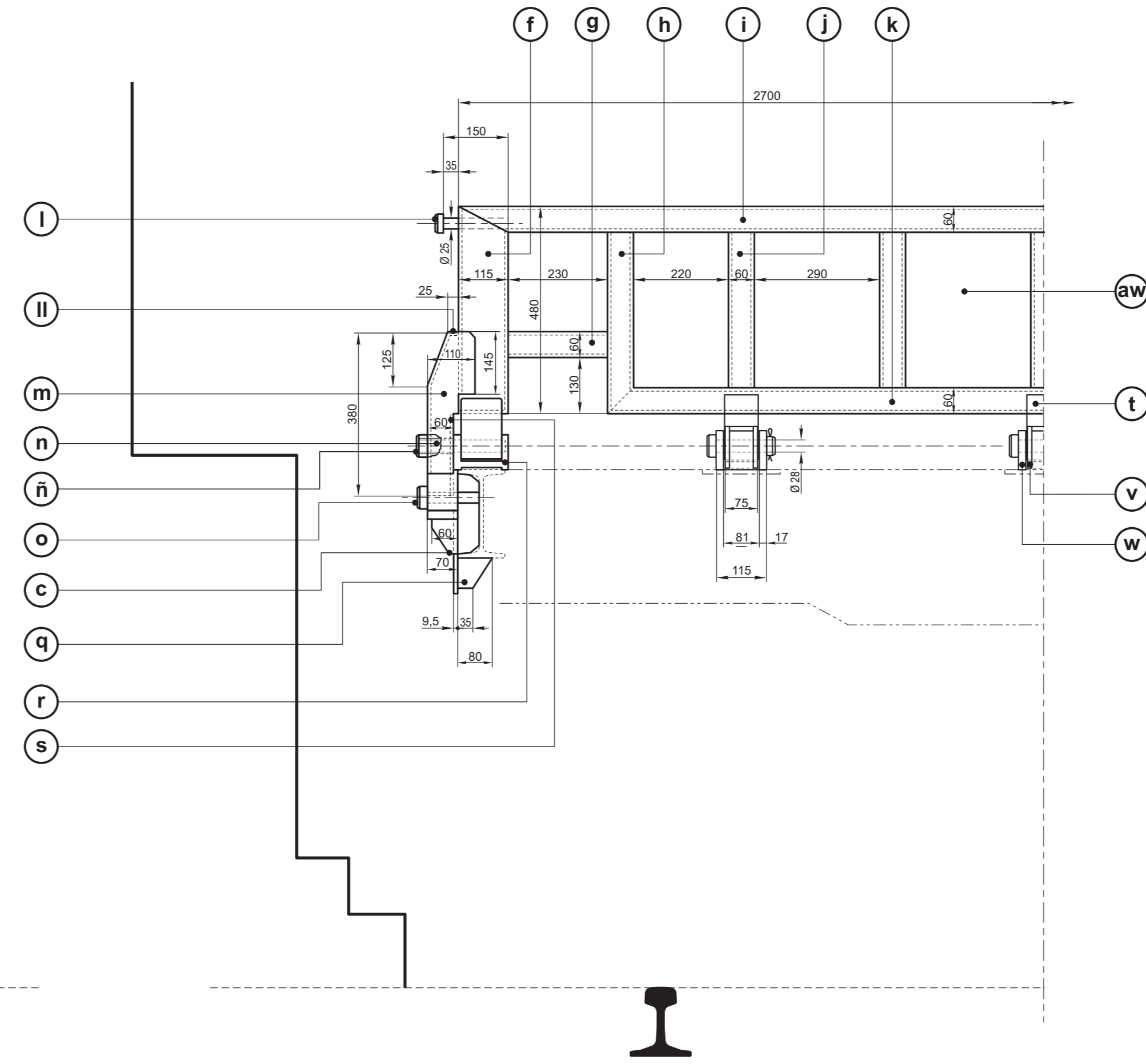

CONJUNTO TENSOR PUERTA
(Esc. 1:2.5)

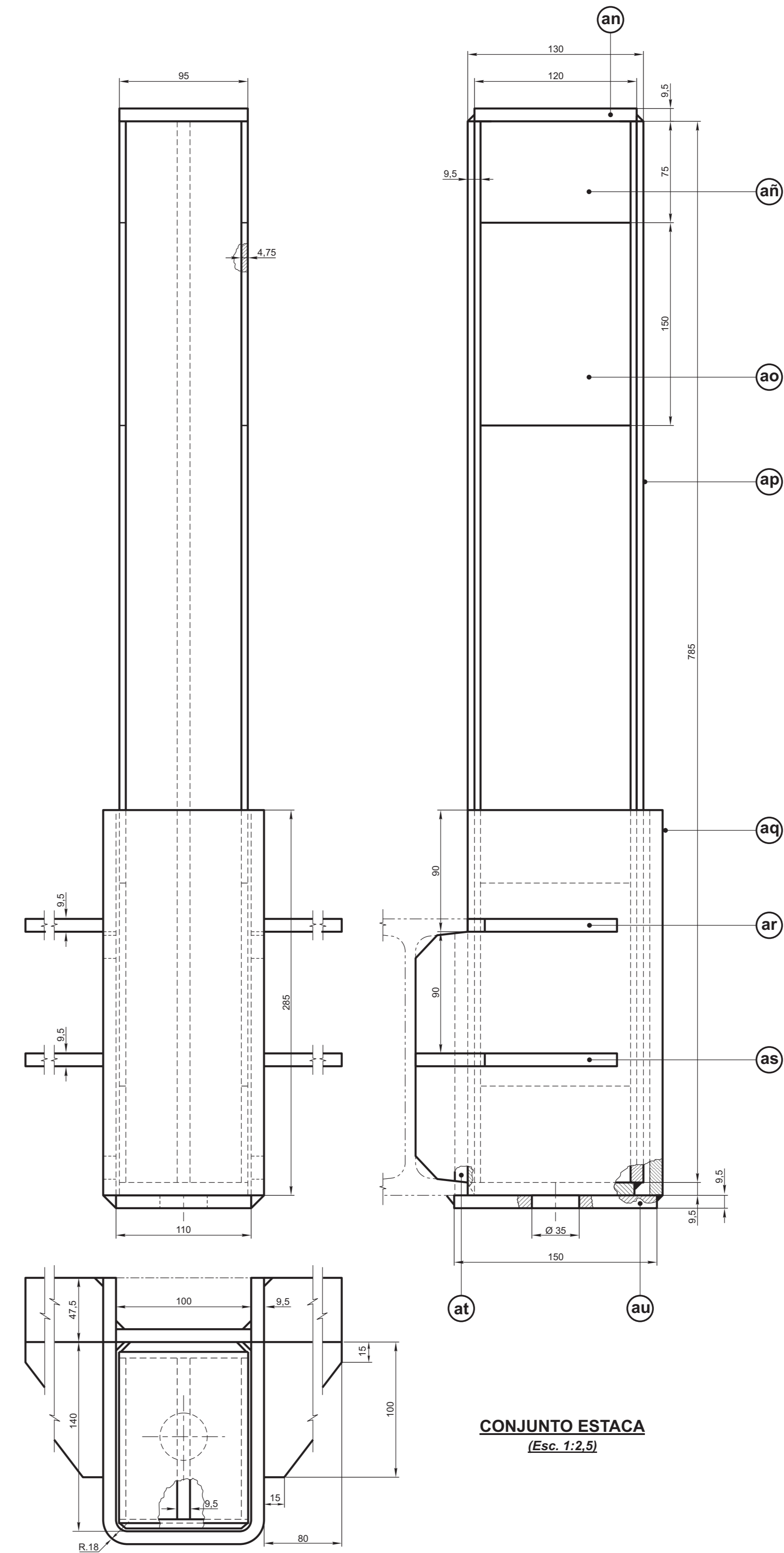

CONJUNTO ESTACA
(Esc. 1:2.5)

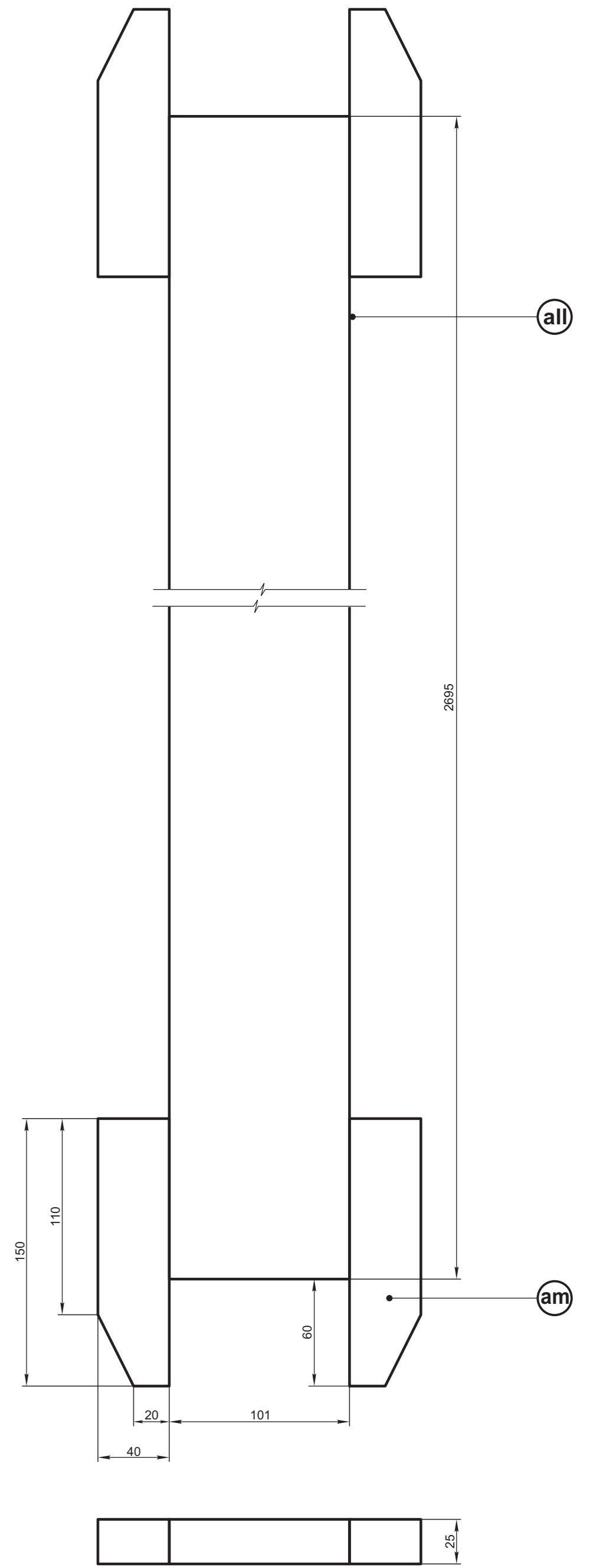

SEPARADOR RIELES
(Esc. 1:2.5)

ITEM	DESCRIPCION	CANT.	ESPECIFICACIONES	OBSERVACIONES	CATALOGO
ax	Chapa de puerta	2	4.75 F 20 - IRAM 503		
aw	Armadura palanca	8	9.5 F 20 - IRAM 503		
av	Fondo estacera	8	9.5 F 20 - IRAM 503		
aa	Complemento estacera	8	9.5 F 20 - IRAM 503		
ab	Nervio largo	16	9.5 F 20 - IRAM 503		
af	Nervio corto	16	9.5 F 20 - IRAM 503		
aq	Estacera	8	9.5 F 20 - IRAM 503		
ap	Ala	16	9.5 F 20 - IRAM 503		
ao	Refuerzo	32	4.75 F 20 - IRAM 503		
ah	Alma	8	9.5 F 20 - IRAM 503		
ai	Extremo estaca	16	9.5 F 20 - IRAM 503		
am	Columna separador	32	25 F 20 - IRAM 503		
aj	Separador nervio	8	25 F 20 - IRAM 503		
al	Refuerzo barra	4	12.5 F 20 - IRAM 503		
ak	Palanca	4	8 F 20 - IRAM 503		
aj	Pasador	4	Ø 12 F 20 - IRAM 503		
al	Soporte pasador	8	6.35 F 20 - IRAM 503		
ah	Eje traba	4	Ø 25 F 20 - IRAM 503		
aj	Soporte tensor	8	12.5 F 20 - IRAM 503		
af	Soje	4	Ø 20 - SAE 1045		
ah	Eje palanca	4	Ø 30 - SAE 1045		
aj	Traba barra	4	Ø 19 F 20 - IRAM 503		
ac	Arandela de ajuste	4	Ø 19 F 20 - IRAM 503		
ab	Arandela tope	4	30 E - IRAM 5107 TABLA I		
aa	Barras tensores	4	Ø 25 F 20 - IRAM 503		
z	Pasador de alata	6	TIPO A-F 20-8-40 - IRAM 5146		
y	Arandela	6	30 E - IRAM 5107 TABLA I		
x	Perno	6	Ø 26 - SAE 1045		
w	Articulacion faja	10	ACERO FUNDIDO SAE 1020-1030		
v	Tope 30° Complemento	6	9.5 F 20 - IRAM 503		
l	Articulacion movil	10	ACERO FUNDIDO SAE 1020-1030		
s	Costado interior	4	4.75 F 20 - IRAM 503		
f	Anillo seguridad eje	4	DIN 471-280		
q	Escuadra para placa	8	9.5 F 20 - IRAM 503		
p					
o	Perno tope	4	Ø 28 - SAE 1045		
n	Perno extremo	4	Ø 28 - SAE 1045		
m	Soje	4	E 102.38 - IRAM 2092 TABLA II		
l	Tope puerta	4	4.75 F 20 - IRAM 503		
k	Cierre superior tope puerta	4	4.75 F 20 - IRAM 503		
j	Perno	4	Ø 25 - SAE 1045		
i	Misero (inferior largo)	2	4.75 F 20 - IRAM 503		
h	Misero (superior)	2	4.75 F 20 - IRAM 503		
g	Misero (Complemento)	4	4.75 F 20 - IRAM 503		
f	Misero (inferior corto)	4	4.75 F 20 - IRAM 503		
e	Misero (latera)	4	4.75 F 20 - IRAM 503		
d	Placa soporte tensor	4	9.5 F 20 - IRAM 503		
c	Fondo	4	4.75 F 20 - IRAM 503		
b	Escuadra de traba	4	12.5 F 20 - IRAM 503		
a	Traba faja	4	20 F 20 - IRAM 503		
s	Tope en bastidor	4	70 F 20 - IRAM 503		

DETALLE ESTACAS, PUERTAS FRONTALES SEPARADORES RIELES Y TENSORES				
ITEM	DESCRIPCION	CANT.	ESPECIFICACIONES	OBSERVACIONES
FEACORRILES ARGENTINOS AREA MECANICA				
ESCALA	1:2.5	TROCHA	1676	LINEAS
WFLDQ200	TRANSPORTE	RELES	12.28 x 11.1	CONTENEDORES S.I.C.
FIRMA Y FECHA APROB.	Nº DE PLANO		1	
NEFA 40.501				