

CORTE A-A

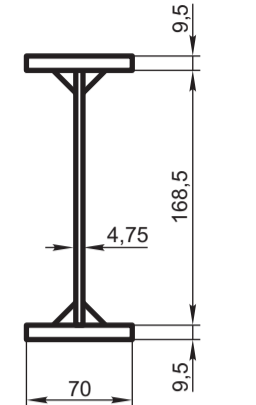

COTA	CANT.	4	4
a		47	42
b		1185	1180

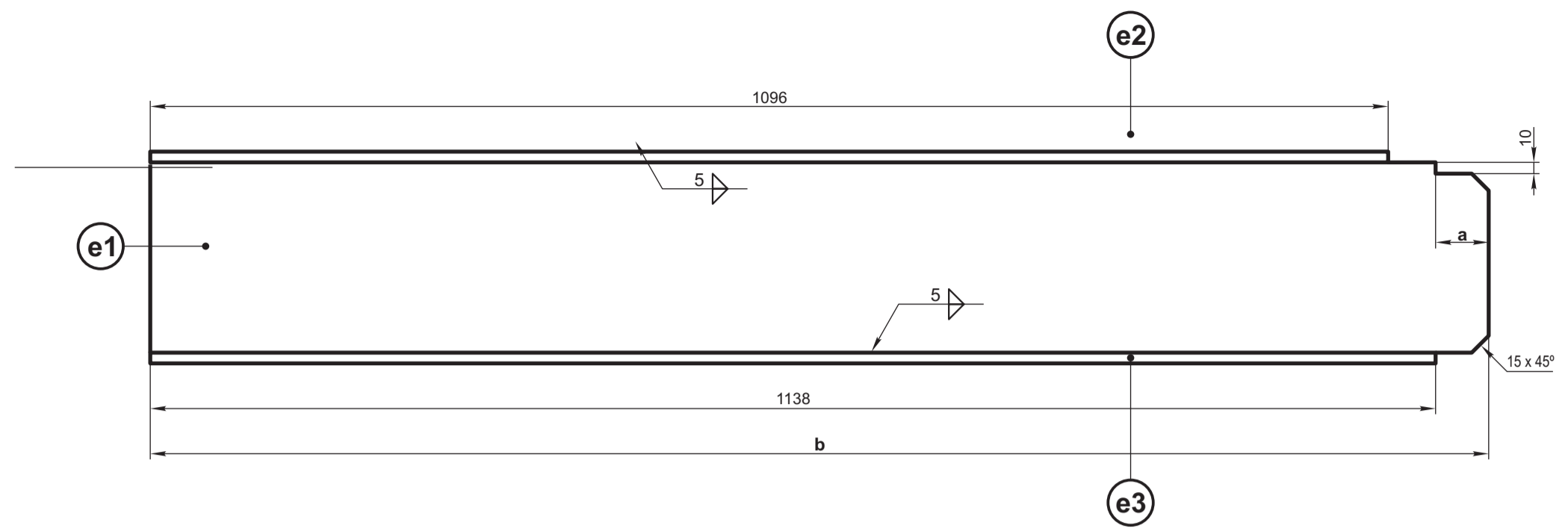
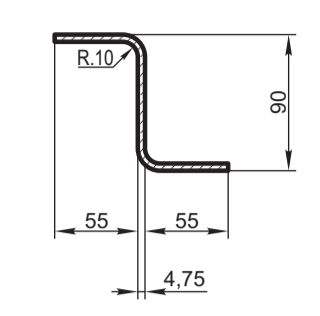
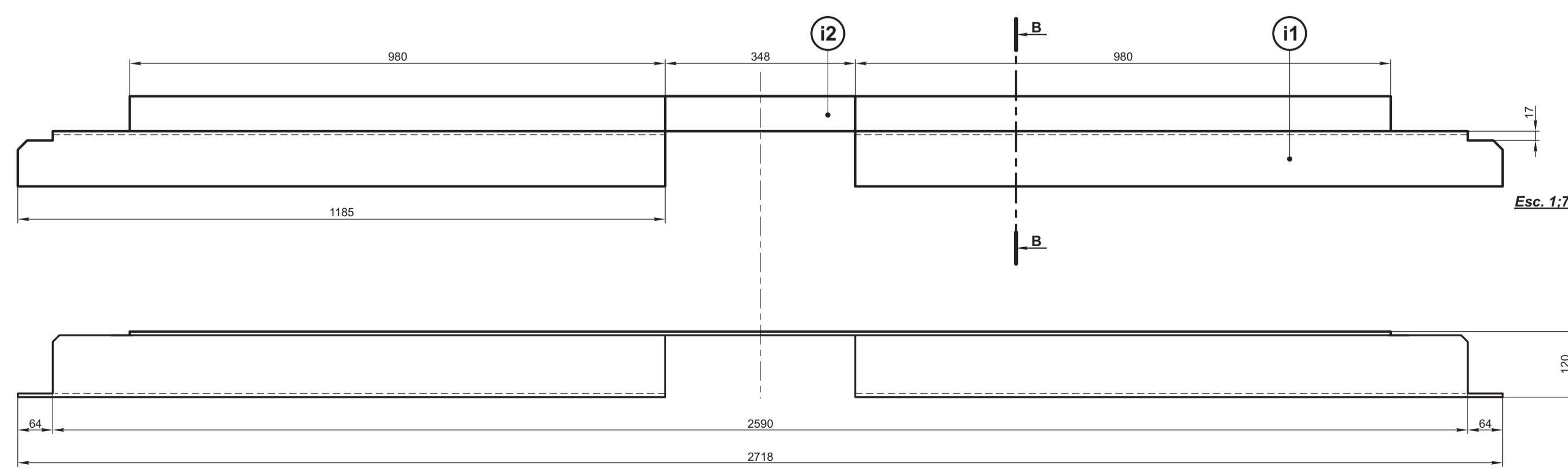
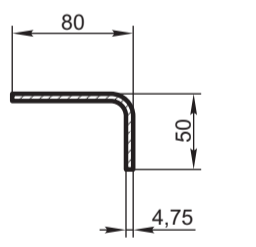
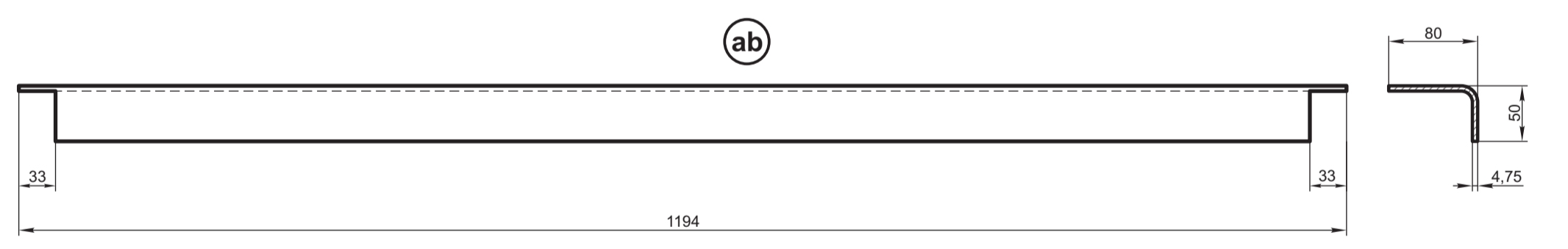
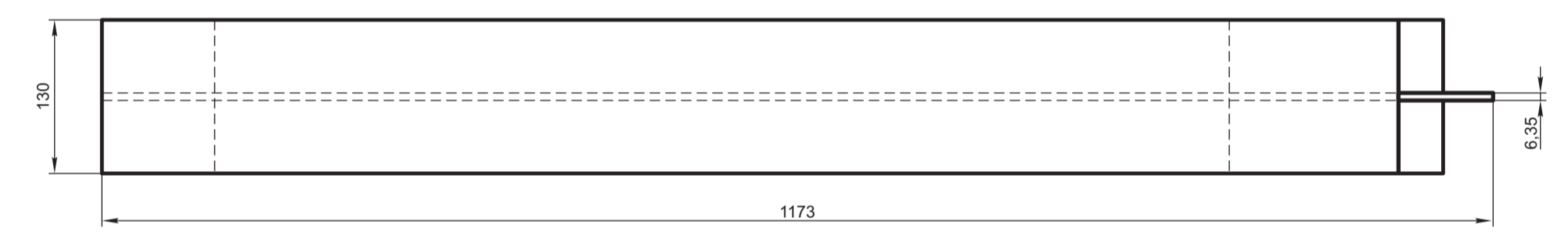
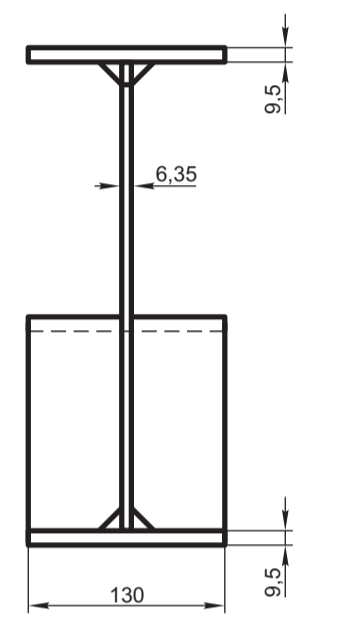
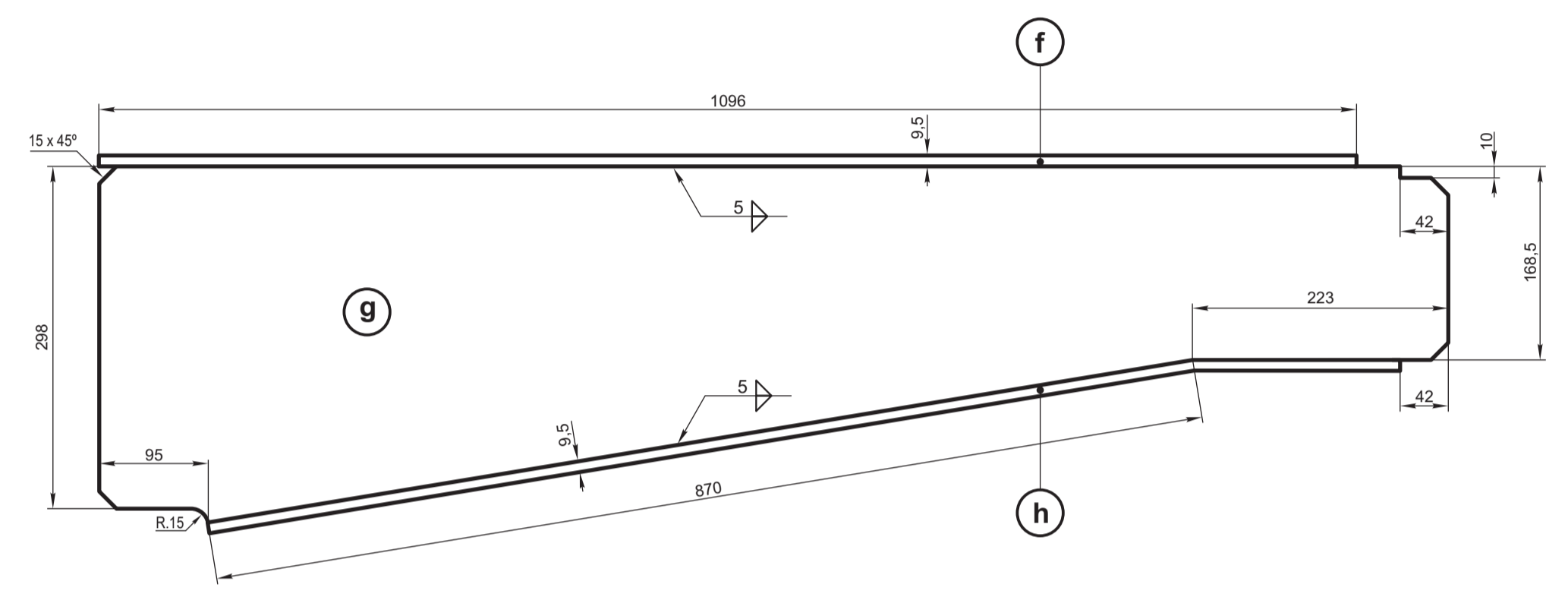

CORTE B-B

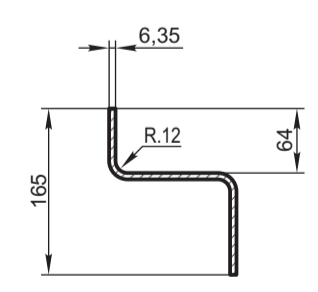

Esc. 1:7.5



ITEM	DESCRIPCION	Cant.	ESCUADRIA, ESPECIFICAC. Y OBSERVACIONES	CATAL-NOMEN.
ab	Angulo refuerzo tanque	1	≠ 4,75 IRAM 503 - F24	
u	Longarina	4	≠ 4,75 IRAM 503 - F24	
t	Longarina	4	≠ 4,75 IRAM 503 - F24	
s	Longarina	4	≠ 4,75 IRAM 503 - F24	
r	Longarina	3	≠ 4,75 IRAM 503 - F24	
q	Longarina	4	≠ 4,75 IRAM 503 - F24	
i2	Chapa unión frente	2	≠ 6,35 IRAM 503 - F24	
i1	Chapa unión frente	4	≠ 6,35 IRAM 503 - F24	
h	Travesaño platabanda	4	≠ 9,5 IRAM 503 - F24	
g	Alma travesaño principal	4	≠ 6,35 IRAM 503 - F24	
f	Travesaño platabanda	4	≠ 9,5 IRAM 503 - F24	
e3	Alma travesaño secundario	8	≠ 9,5 IRAM 503 - F24	
e2	Alma travesaño secundario	8	≠ 9,5 IRAM 503 - F24	
e1	Alma travesaño secundario	8	≠ 4,75 IRAM 503 - F24	

VAGON TOLVA CUBIERTO MULTIUSO
LONGARINAS, TRAVESAÑOS Y
CHAPA UNION FRENTE

FERROCARRILES ARGENTINOS

AREA
MECANICA

ESCALA 1:5 TROCHA 1000 LINEAS UTILIZACION EMISION

FIRMA Y FECHA APROB. N° DE PLANO **1**

NEFA 37.006