

**CORTE A-A**

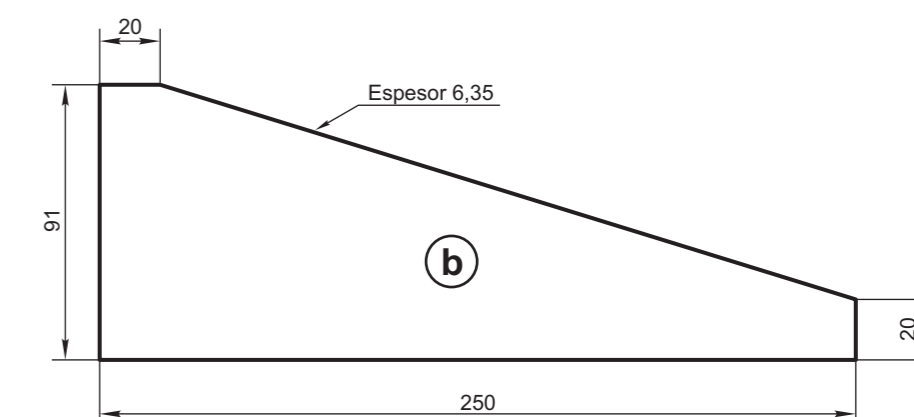

**(E. 1:2,5)**

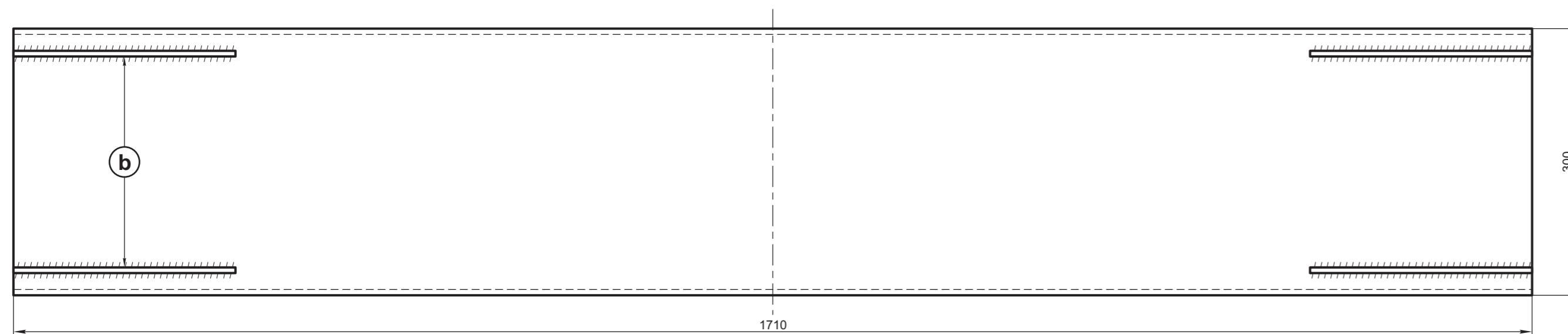
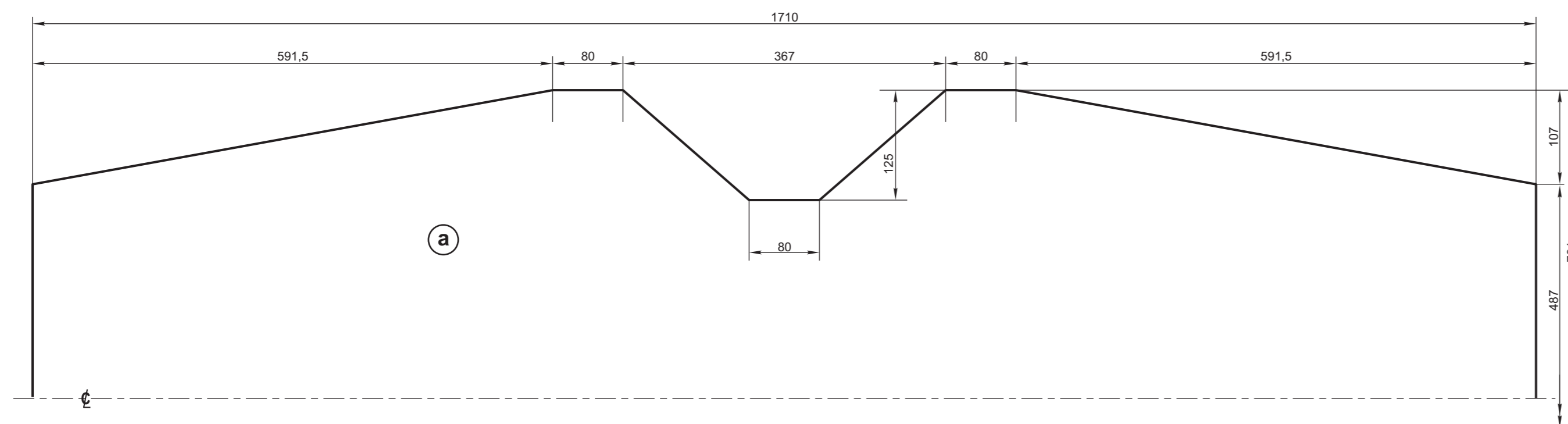

**Media vista desarrollo**

**Cant/Vagón: 4**

**TOLERANCIAS GENERALES**

PIEZAS USINADAS	: ± 0,25 mm
PIEZAS FORJADAS	: ± 0,8 mm
PIEZAS EN CHAPAS	: ± 0,5 mm
ANGULOS	: ± 0,30°
MATAR CANTOS VIVOS	

<b>b</b>	Escuadra refuerzo	16	≠ 6,35 IRAM 503 F24	
<b>a</b>	Travesaño	4	≠ 6,35 IRAM 503 F24	
ITEM	DESCRIPCION	Cant.x Coche	ESCUADRIA, ESPECIFICAC. Y OBSERVACIONES	CATAL-NOMEN.

Fecha:	R. MAZZOLA	Ing. R. CARRIO	Ing. R. CARRIO	<b>VAGON TOLVA ABIERTO PARA PIEDRA</b>		<b>FERROCARRILES ARGENTINOS</b>
	Dibujo			Proyecto	<b>TRAVESAÑO PRINCIPAL</b>	
ESCALA		TROCHA	LINEAS:	UTILIZACION	EMISION	
		1676			<b>1</b>	
FIRMA Y FECHA APROB.			N° DE PLANO			
			<b>NEFA 32.057</b>			