

2 Derechos - 2 Izquierdos

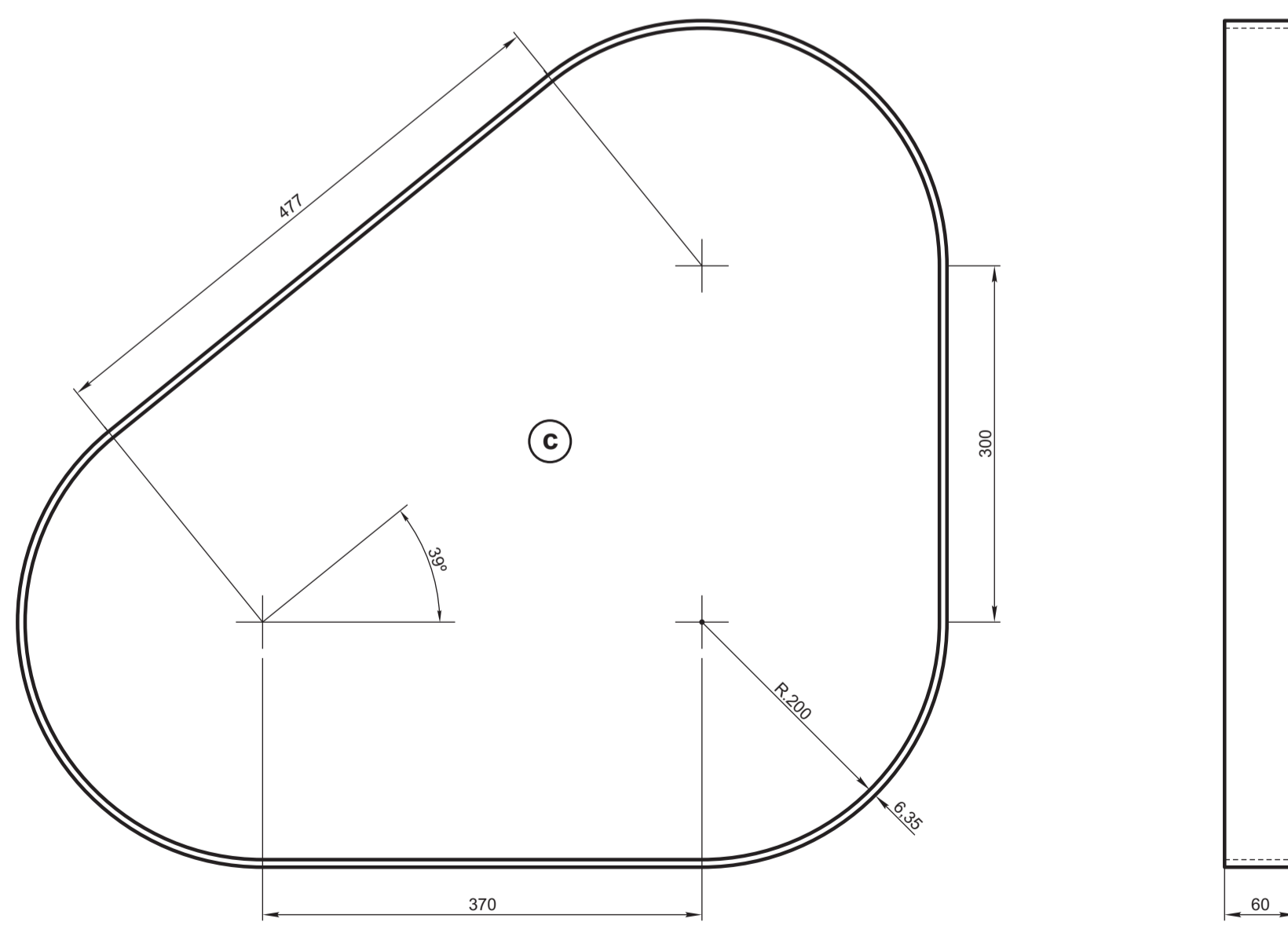

Esc. 1:5

Desarrollo: 6,35 x 60 x 1975

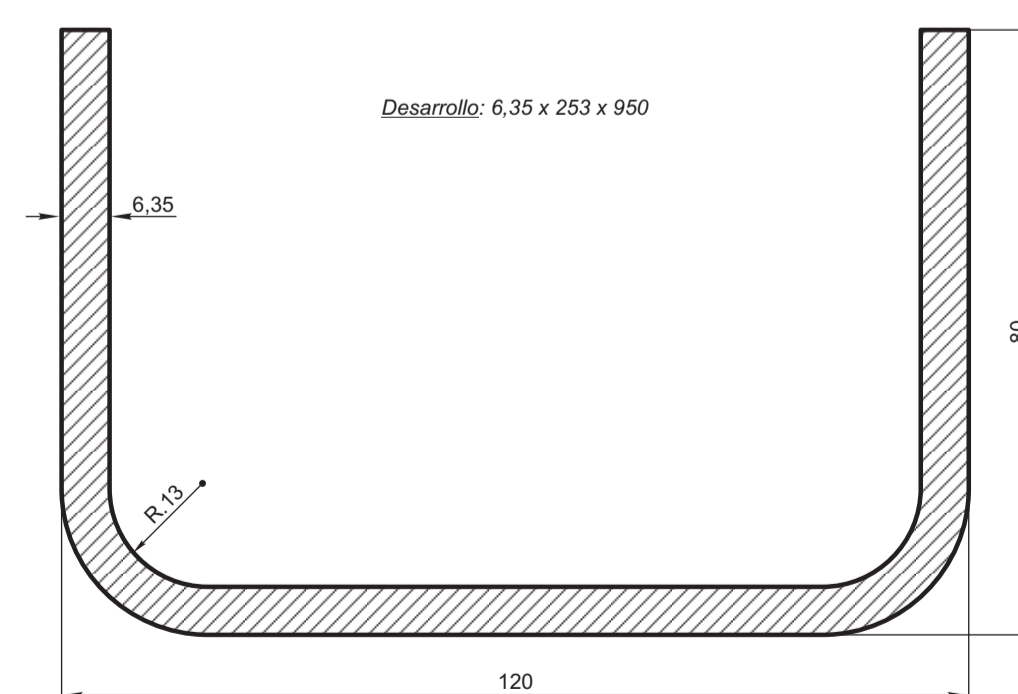
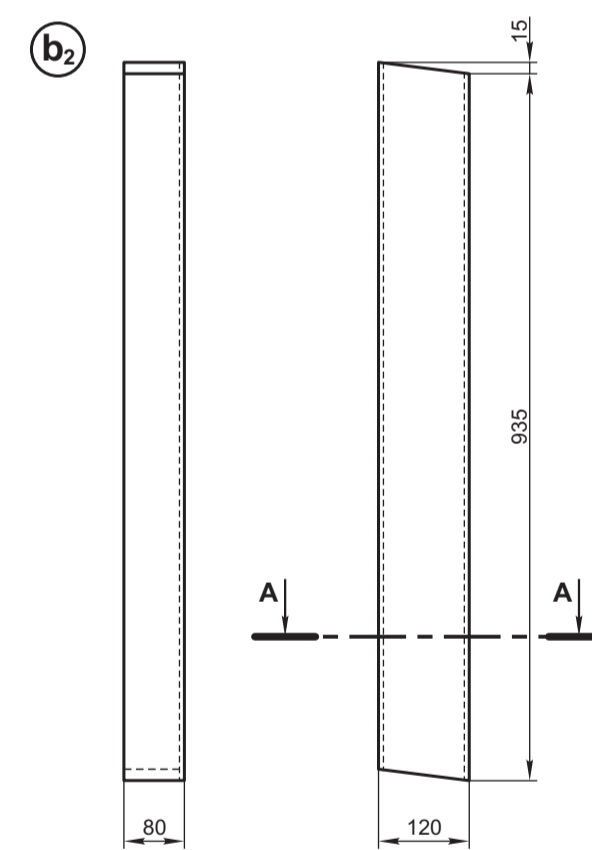

CORTE A-A
Esc. 1:1

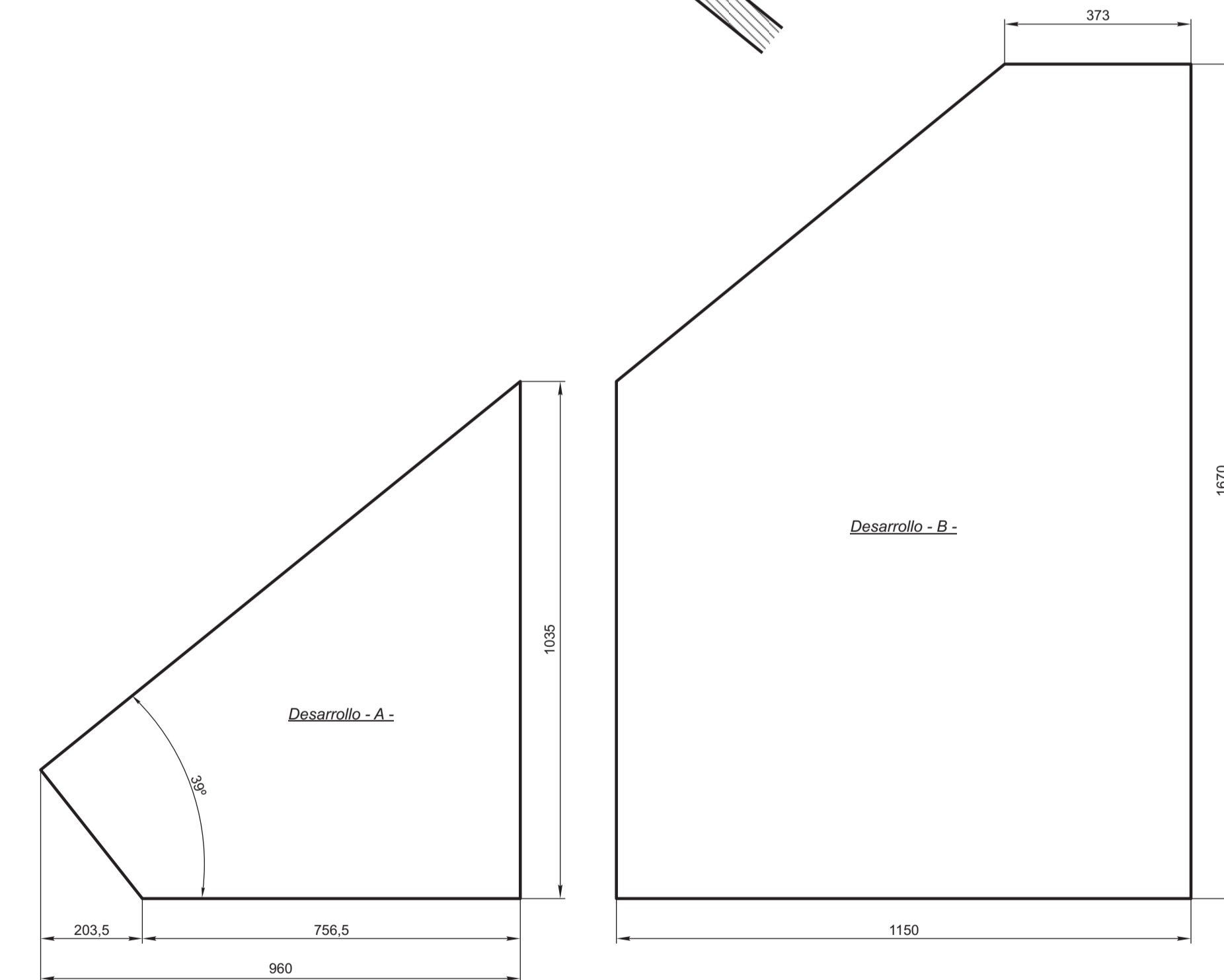

TOLERANCIAS GENERALES

PIEZAS USINADAS	: ± 0,25 mm
PIEZAS FORJADAS	: ± 0,8 mm
PIEZAS EN CHAPAS	: ± 0,5 mm
ANGULOS	: ± 0,30°
MATAR CANTOS VIVOS	

c	Refuerzo escuadra	4	≠ 6,35 IRAM 503 - F.22	13-03-007
b1	Escuadra superior	4	≠ 6,35 IRAM 503 - F.22	13-03-006
b2	Escuadra inferior	4	≠ 6,35 IRAM 503 - F.22	13-03-004/005
ITEM	DESCRIPCION	Cant.	ESCUADRIA, ESPECIFICACION, OBSERVAC.	CATAL. NOM.

**VAGON TOLVA GRANERO
ESCUADRA EXTERIOR
- FRENTE -**

**FERROCARILES
ARGENTINOS**
AREA
MECANICA

ESCALA	1:10	TROCHA	1676	LINEAS		UTILIZACION		EMISION	
--------	------	--------	------	--------	--	-------------	--	---------	--

FIRMA Y FECHA APROB.		N° DE PLANO	NEFA 24.027	1	2
----------------------	--	-------------	-------------	---	---

2	Modificación pieza b1	FECHA - FIRMA	
EMISION	COTA	ALTERACIONES	