

CORTE A-A

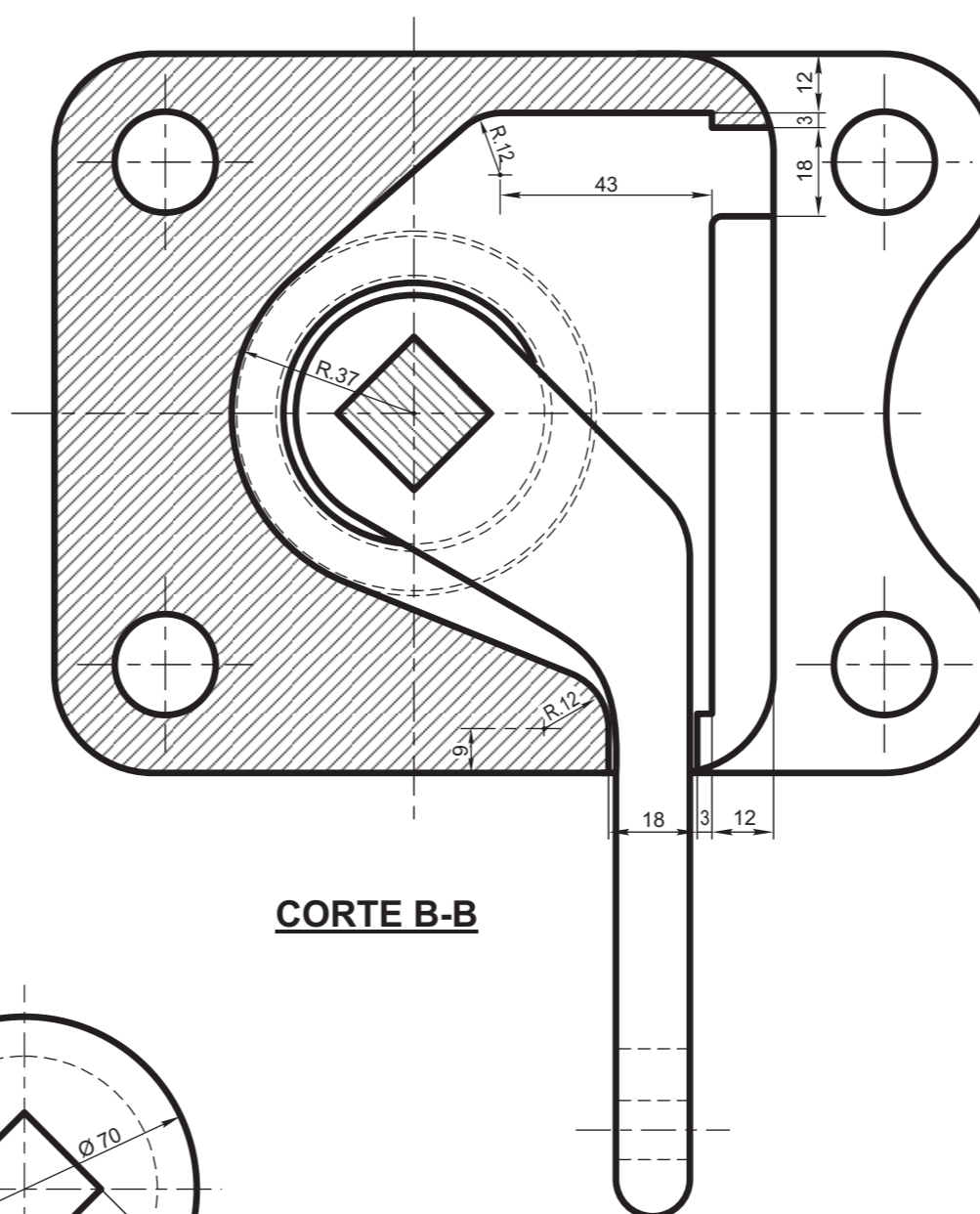

CORTE B-B

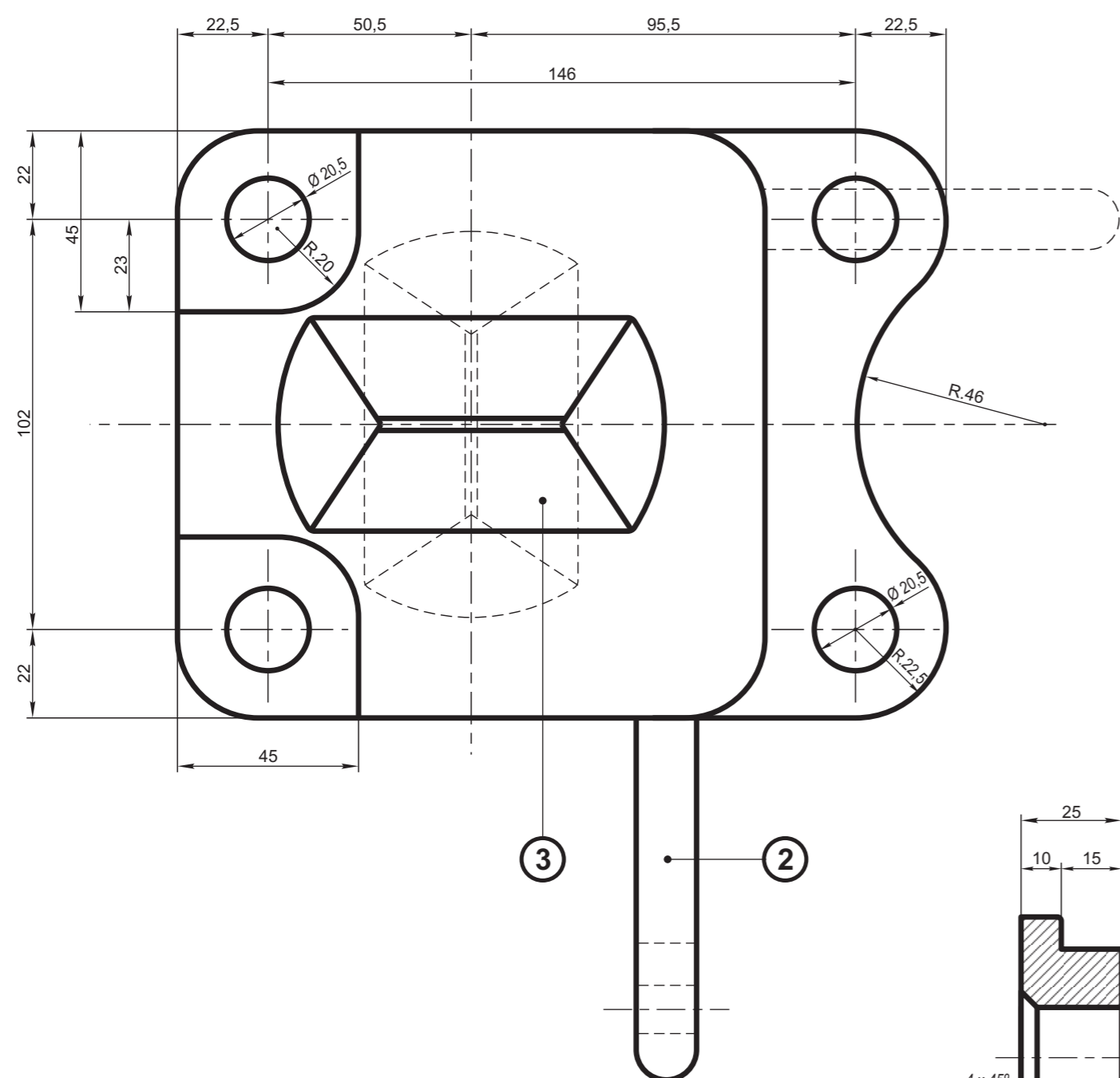
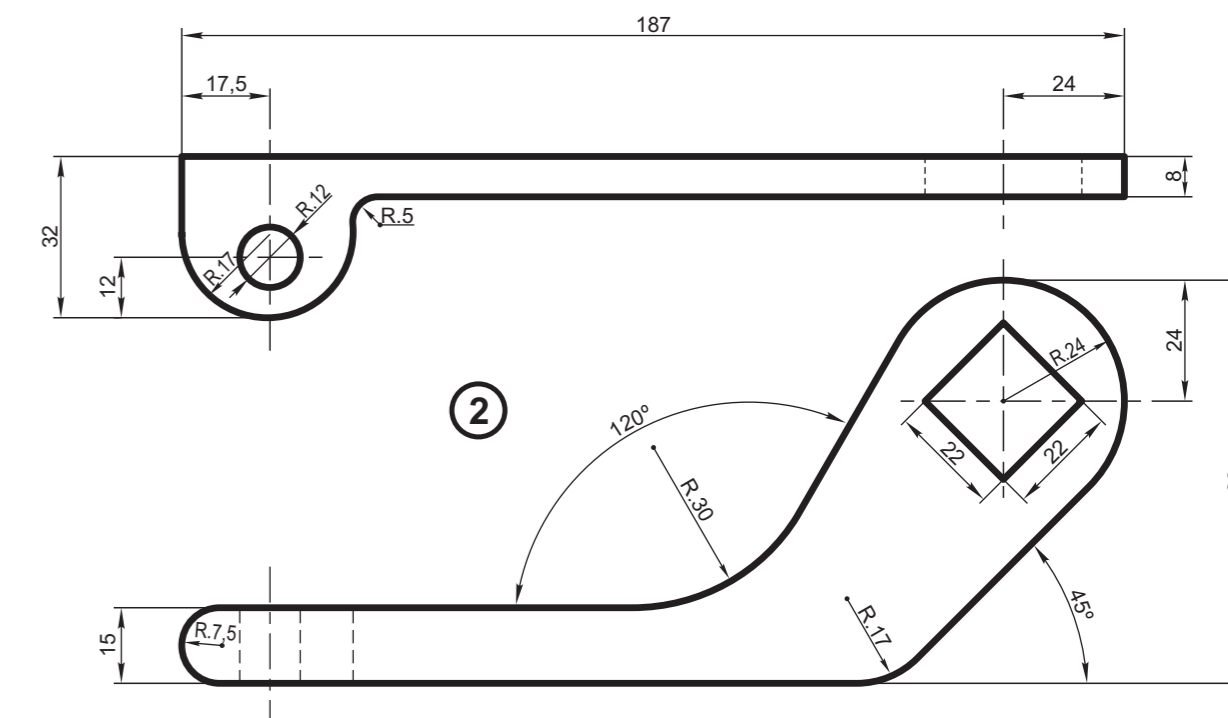
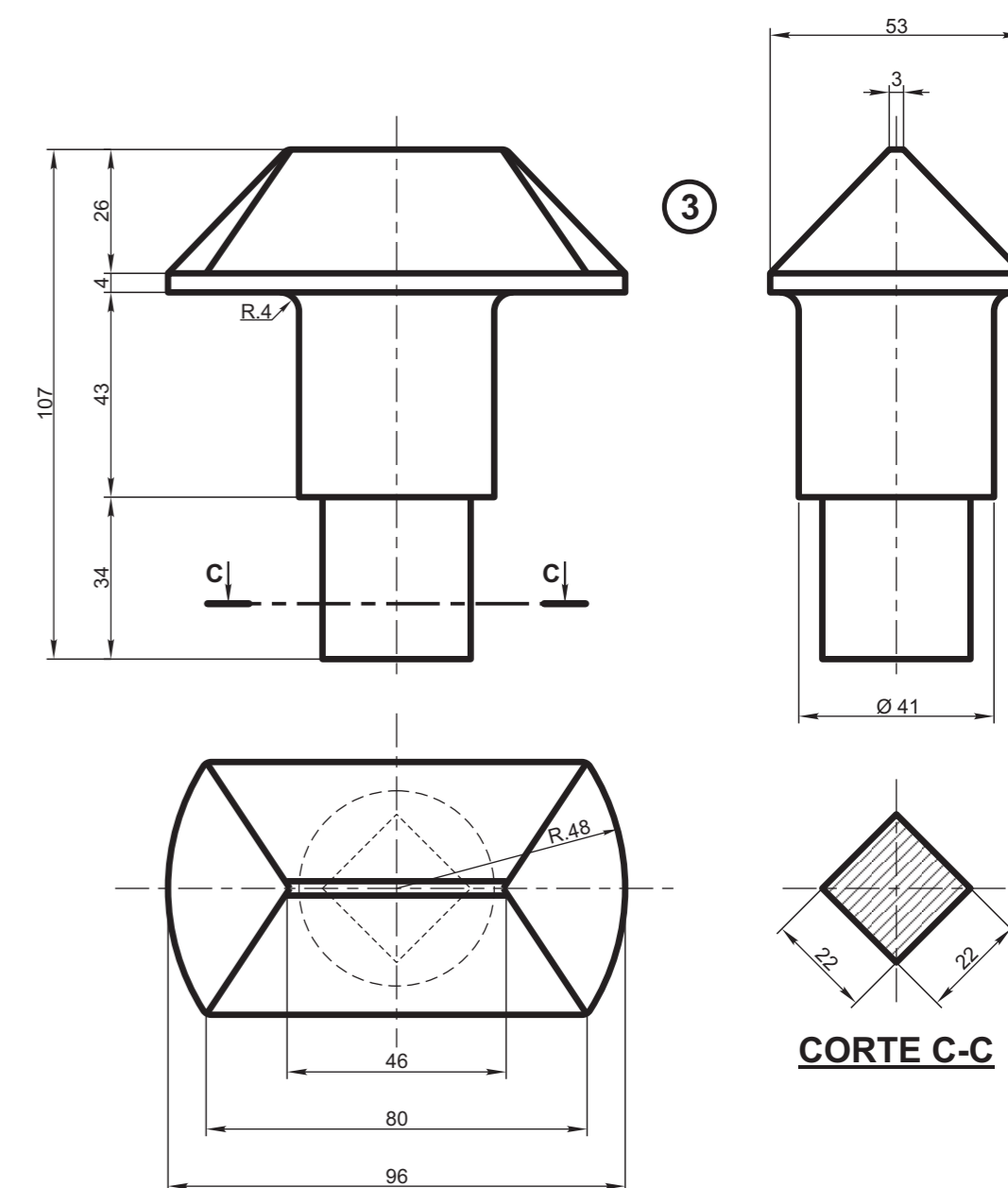

CORTE C-C

NOTA: Cantidad por vagón: 4 der. y 4 izq.

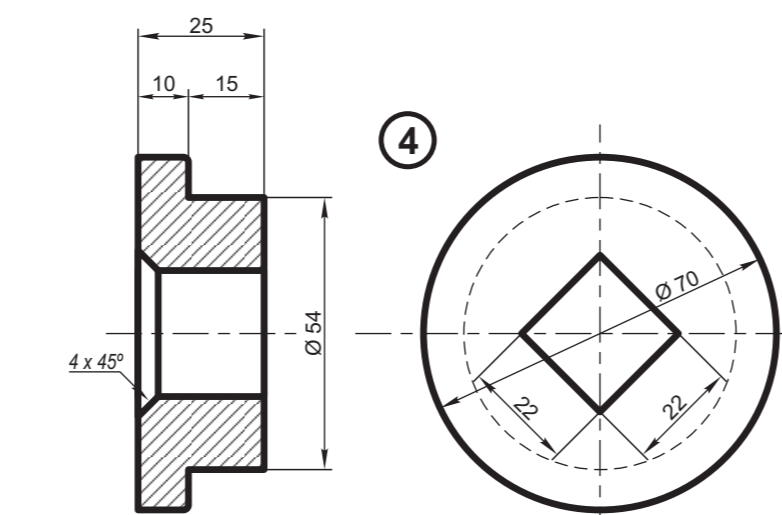

2	Cambio de material (Anterior: F.A. 8 715 - Grado FMNP 3512)	
EMISION	COTA	ALTERACIONES
		FECHA - FIRMA

4	BUJE TOPE	8 p.v.	
3	TRABA	8 p.v.	
2	PALANCA ACCIONAMIENTO	4 der. 4 izq.	
1	CUBO	4 der. 4 izq.	F.A. 8 701 - Grado B
ITEM	DESCRIPCION	CANT.	ESCUADRIA, ESPECIF. Y OBSERVACIONES
			CATAL. - NOMENC.

VAGON PARA TRANSPORTE DE CONTENEDORES TIPO 1 C DISPOSITIVO SUJECION			FERROCARRILES ARGENTINOS	
			AREA MECANICA	
ESCALA 1:1,5	TROCHA 1000	LINEAS:	UTILIZACION VAGONES	EMISION 1 2
FIRMA Y FECHA APROB.			N° DE PLANO NEFA 21.001	