

Sin Escala

**NOTA**  
Se deberán proveer 3 (tres) separadores por vagón

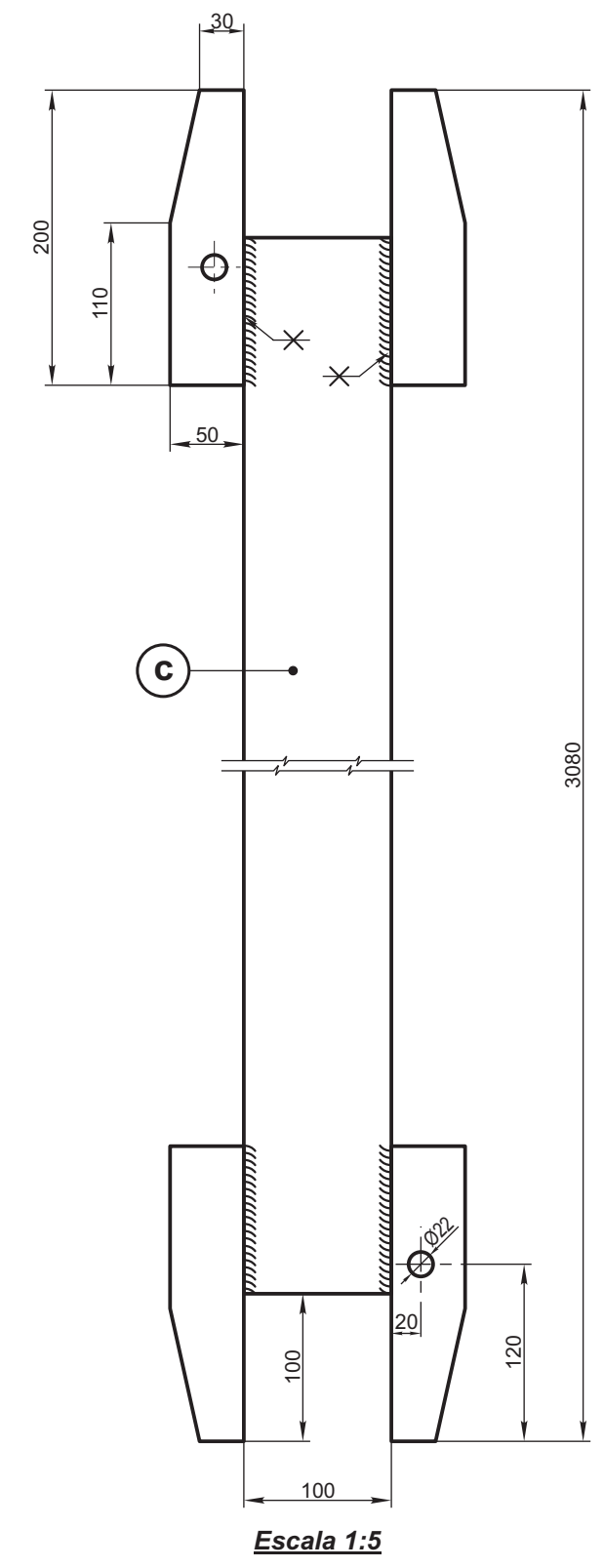

Escala 1:5

Las cantidades son por vagón

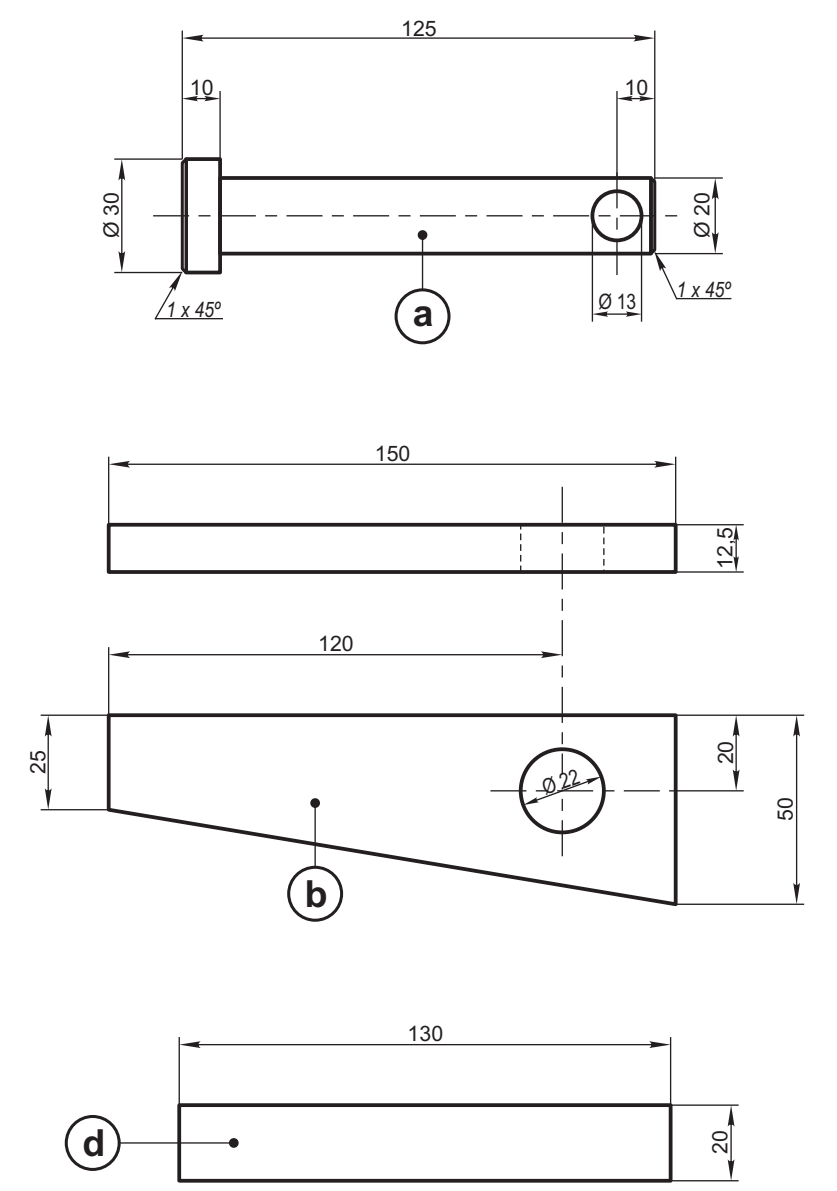

Escala 1:2

ITEM	DESCRIPCION	CANT.	ESCUADRIA, ESPECIFICACION, OBSERVAC.	Kg.	CATAL.NOM.
d	Traba separador	2	IRAM 503 - F.20 $\neq$ 9,5		
c	Separador	3	IRAM 503 - F.20 $\neq$ 25		
b	Base separador	1	IRAM 503 - F.20		
a	Perno p/precinto	1	IRAM 503 - F.20		

**CONVERSION VAGON C19 A TRANSPORTE RIEL  
SEPARADOR DE RIELES**

**FERROCARRILES ARGENTINOS**  
AREA  
**MECANICA**

ESCALA 1:2 - 1:5	TROCHA 1676	LINEAS:	UTILIZACION	EMISION
FIRMA Y FECHA APROB.			N° DE PLANO <b>NEFA 1269</b>	<b>1</b>