

QUITAR REBABAS
ELIMINAR CANTOS VICOS
0.5 x 45!

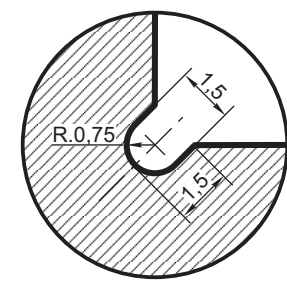

DETALLE 1
(Esc. 5:1)

| ITEM | EJE | DIMENSIONES | | | | | |
|------|--------------|-------------|-----|-----|------|-----|-----|
| | | U | Ø V | Ø W | R | Ø S | Ø T |
| B | 4 1/4" x 8" | 260 | 115 | 102 | 19,1 | 115 | 102 |
| C | 5" x 9" | 290 | 135 | 120 | 19,1 | 135 | 120 |
| D | 5 1/2" x 10" | 290 | 145 | 132 | 19,1 | 145 | 132 |
| E | 6" x 11" | 315 | 160 | 145 | 19,1 | 160 | 145 |
| F | 6 1/2" x 12" | 335 | 172 | 158 | 25,4 | 172 | 158 |

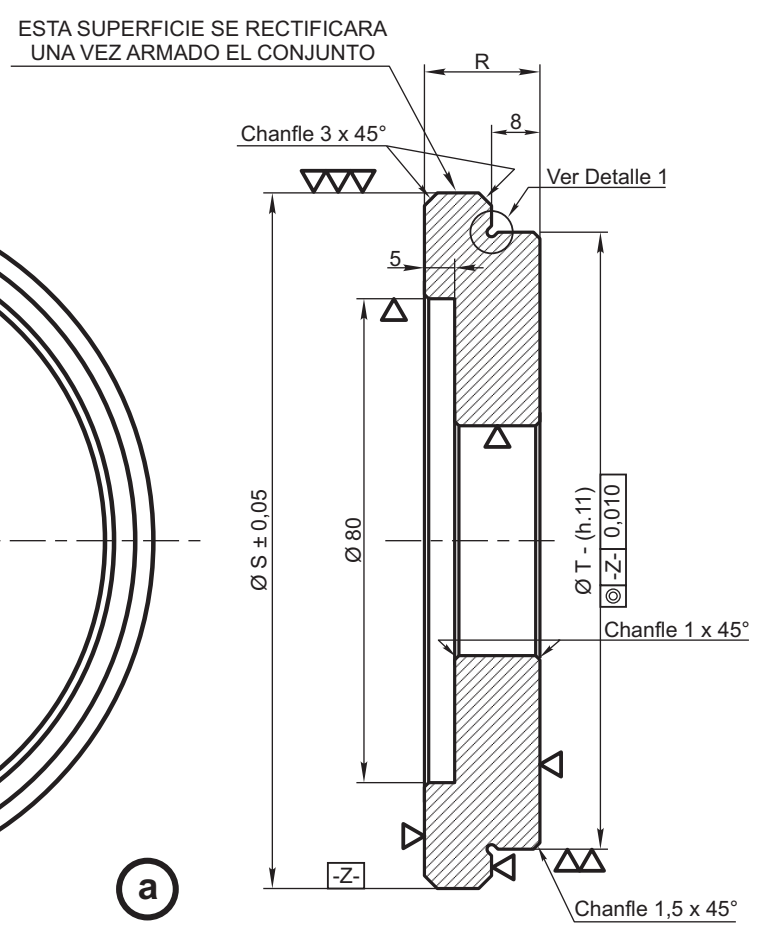
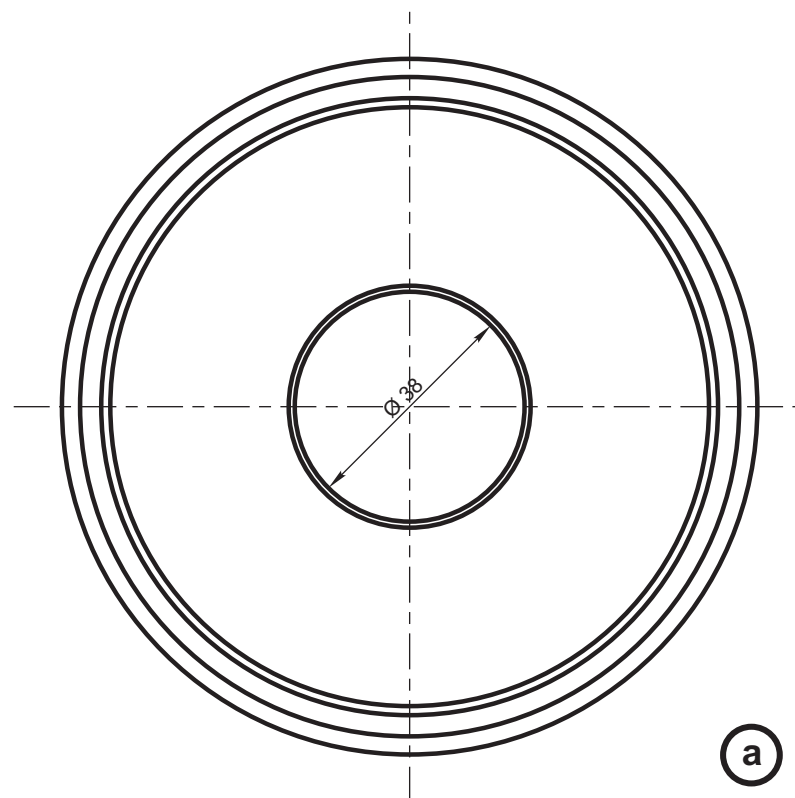

(Esc. 1:1,25)

| | | | | |
|-----------------------------------------|---------------|--------------|-----------------------------------------|--------------|
| b | Manga | | ACERO IRAM 600 - CLASE 1045 | |
| a | Guía de Manga | | ACERO IRAM 600 - CLASE 1045 | |
| ITEM | DESCRIPCION | Cant.x Coche | ESCUADRIA, ESPECIFICAC. Y OBSERVACIONES | CATAL-NOMEN. |
| MANGA PARA CALADO DE RODAMIENTOS | | | FERROCARRILES ARGENTINOS | |
| | | | AREA MECANICA | |
| ESCALA | TROCHA | LINEAS: | UTILIZACION | EMISION |
| | TODAS | TODAS | VAGONES | 1 |
| FIRMA Y FECHA APROB. | | N° DE PLANO | | |
| | | NEFA 950 | | |