

b TERMINACION LAMINADO EN VAGONES
Y MECANIZADO RUSTICO EN COCHES

ITEM	PARA EJE	s	t	u
B	4 1/4" x 8"	290	152	255
C	5" x 9"	290	178	255
D	5 1/2" x 10"	290	190	255
TOLERANCIAS	+			
	-			

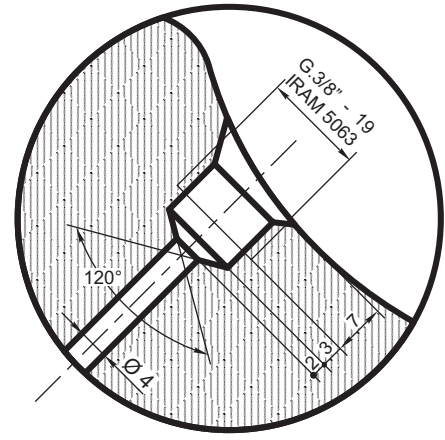

DETALLE "1"

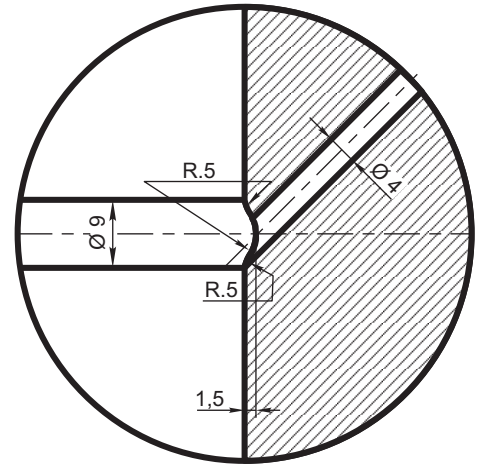

DETALLE "2"

○ ⊕ Ⓢ — Norma ISO TC 10

ITEM	DESCRIPCION	Cant.x Coche	ESCUADRIA, ESPECIFICAC. Y OBSERVACIONES	CATAL-NOMEN.
<p align="center">RUEDAS ENTERIZAS LAMINADAS DE Ø 953 mm</p>			<p>FERROCARRILES ARGENTINOS</p>	<p>AREA MECANICA</p>
ESCALA	TROCHA	LINEAS:	UTILIZACION	EMISION
1:2,5 1:1	1435 - 1676		MATERIAL REMOLCADO	1
FIRMA Y FECHA APROB.		N° DE PLANO		
		NEFA 937		