

ITEM	EJE	DIMENSIONES										
		C	C.1	Ø D	Ø D.1	H	H.1	L	R	R.1	R.2	R.3
B	4 1/4" x 8"	188	118	19,1	22	160	45	230	65 ± 0,5	73 ± 0,5	21	19
C	5" X 9"	209	139	19,1	22	180	55	250	76 ± 0,5	84 ± 0,5	20,5	19
D	5 1/2" X 10"	220	150	19,1	22	190	60	260	82 ± 0,5	90 ± 0,5	20	19
E	6" X 11"	238	168	22,2	26	210	70	280	90 ± 0,5	98 ± 0,5	21	19
F	6 1/2" X 12"	254	184	22,2	26	230	80	300	96 ± 0,5	104 ± 0,5	23	19

CORTE D-D

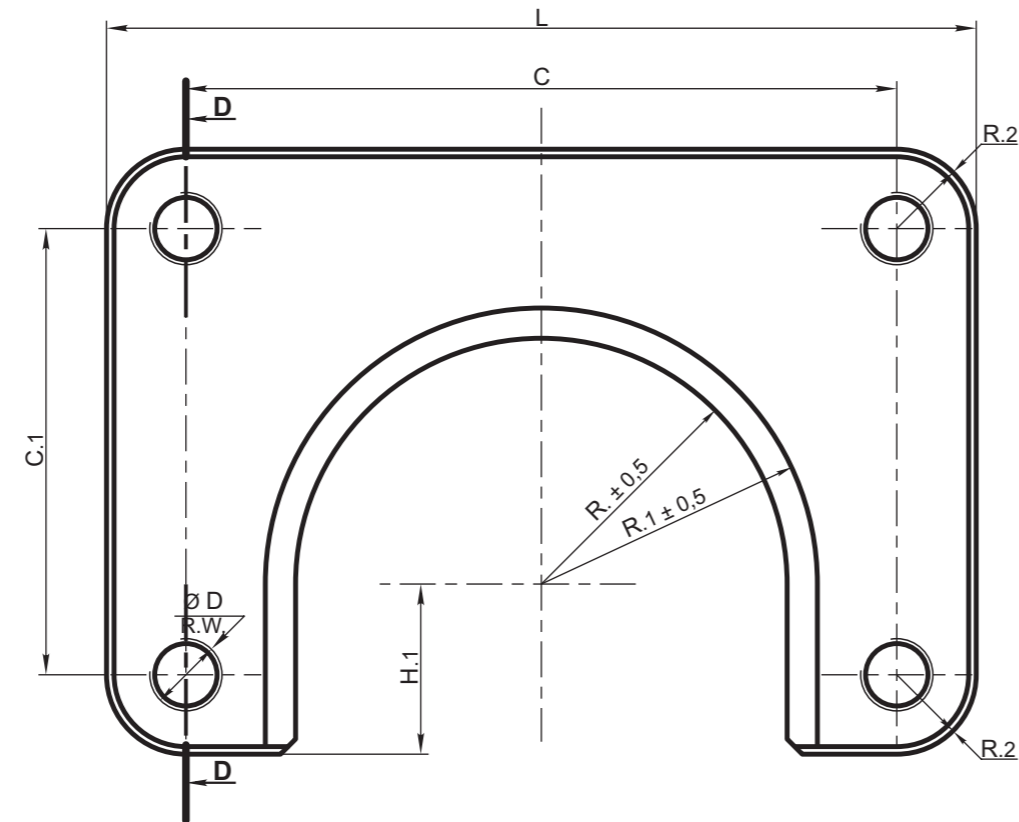
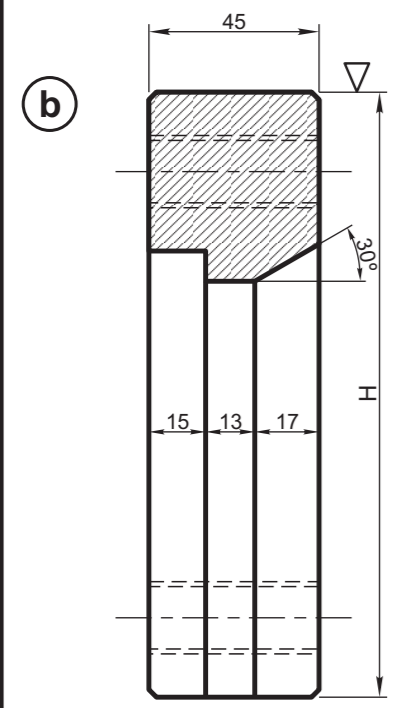

QUITAR REBABAS
ELIMINAR CANTOS VIVOS 2 x 45°

b	Patin extractor		Acero IRAM 600 - Clase 1045	
a	Patin de apoyo		Acero IRAM 600 - Clase 1045	
ITEM	DESCRIPCION	CANT.	OBSERVACIONES	CATAL-NOMEN.
PATIN DE APOYO Y PATIN EXTRACTOR DISPOSITIVO PARA DECALADO DE RODAMIENTOS				FERROCARRILES ARGENTINOS
				AREA MECANICA
ESCALA 1:2	TROCHA TODAS	LINEAS: TODAS	UTILIZACION VAGONES	EMISION
FIRMA Y FECHA APROB.			N° DE PLANO NEFA 901	1