

OFFICE OF ORIGIN F.C.	DRAWN F.C.	CHECKED F.C.
REVISED F.C.S. & F.C.O.	REVISED .C.C.A.	REVISED F.C.P.

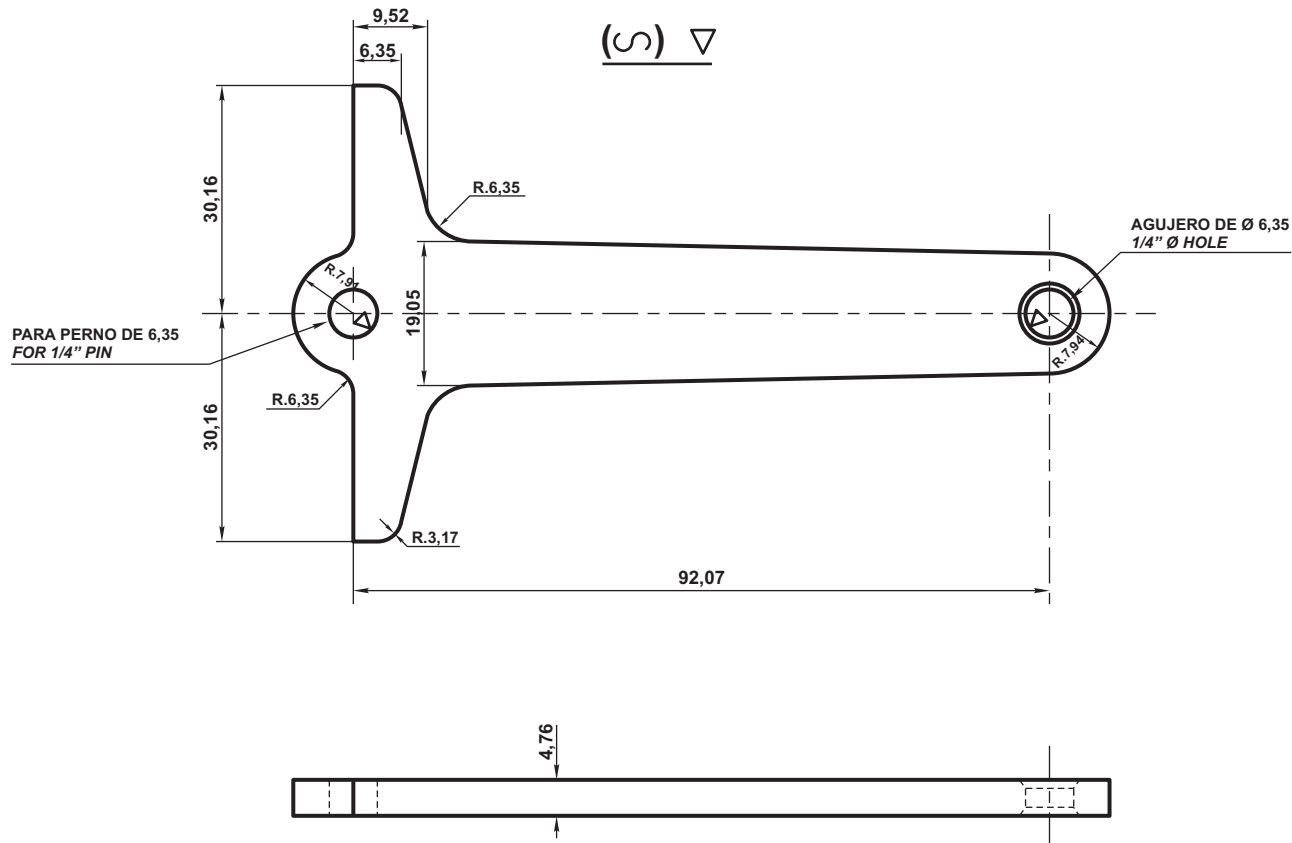

CADA PIEZA SE MARCARA SEGUN A.B.G.S. DIB. N° 707
EACH PIECE TO BE MARKED IN ACCORDANCE WITH A.B.G.S. DWG N° 707

REFERENCE PLANS		MATERIAL	N° PER SET	OBSERVATIONS & SPECIFICATION	CHIEF MECHANICAL ENGINEERS	ARGENTINE BOARD GAUGE STANDARD		
PLANOS DE REFERENCIA		MATERIAL	N° POR JUEGO	OBSERVACIONES & ESPECIFICACION	INGENIEROS JEFES MECANICOS	VALVULA DE AFLOJAMIENTO DE CILINDRO F.V. - LEVA TIPO TE		
TITLE - TITULO	N°	ACERO DULCE MILD STEEL		IRAM A.37 - 525 I	F.C.S.	RELEASE VALVE FOR V.B. CYLINDERS - TEE TYPE LEVER		
VALVULA PARA COLOCAR AL COSTADO VALVE FOR SIDE FITTING	742				F.C.O.	DATE: FECHA: 28/7/37	SCALE: ESCALA:	
VALVULA PARA COLOCAR ABAJO VALVE FOR BOTTOM FITTING	760				F.C.C.A.	COPY N° - COPIA N°	DRAWING N° DIBUJO N°	A.B.G.S. 766
		F.C.P.						