

TOLERANCIAS NO ESPECIFICADAS
 JS.13 = js.13
 IRAM 5002

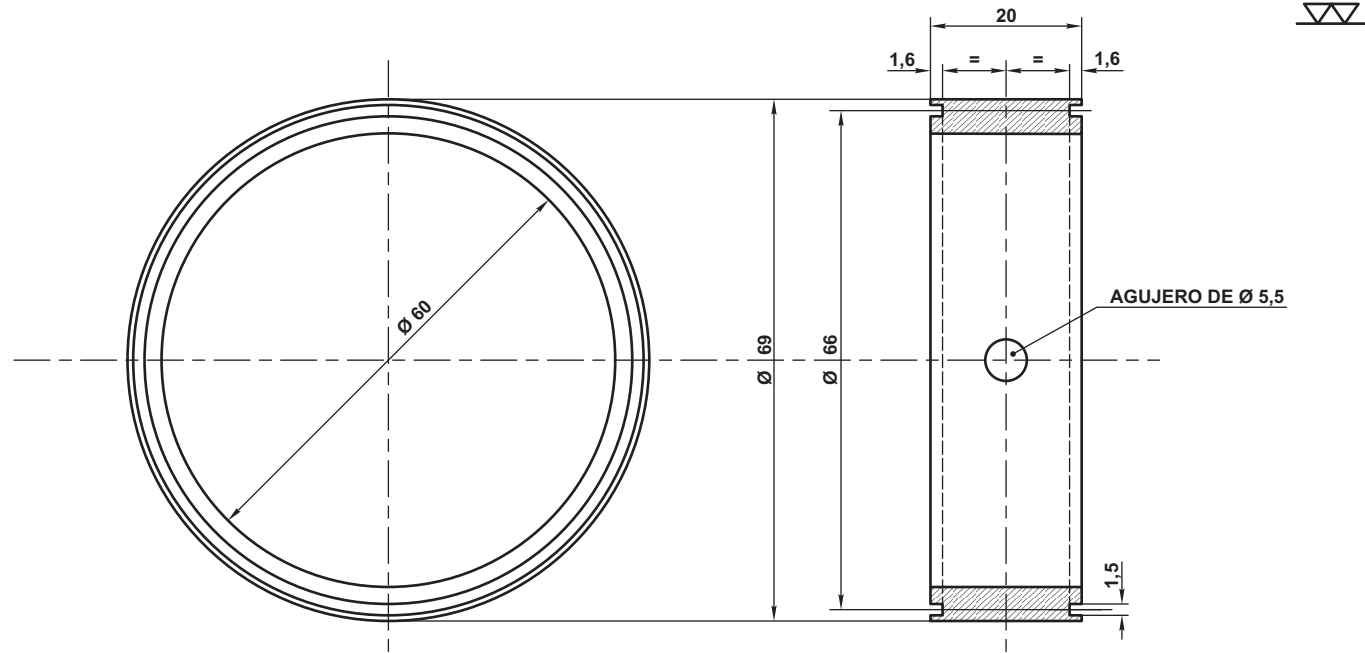

PIECE N° 732
 PIEZA

N.U.M. 9050502

CAT. ROCA FV 15014

EACH RING TO BE MARKED IN ACCORDANCE WITH A.B.G.S. DRG. N° 707. (WITH PAINT, NO MARKS TO BE STAMPED).
 CADA ANILLO SE MARCARA SEGUN A.B.G.S. DIB. N° 707 (CON PINTURA, SIN ESTAMPAR)

NOTE: MARCHINE ALL OVER
 NOTA: TODO TERMINADO A MAQUINA

| | | |
|--|---------|----------|
| OFFICE OF ORIGIN REVISED | DRAWN | CHECKED |
| | REVISED | REVISADO |
| | TRACED | |
| | REVISED | |
| 2) Se modificó. Especificación - 20/10/71 3) Se ajustaron dimensiones - 29/7/81 | | |

| PREFERENCE PLANS | | MATERIAL | N° PER SET | OBSERVATIONS & SPECIFICATION | CHIEF MECHANICAL ENGINEERS | | ARGENTINE BROAD GAUGE STANDARD | | |
|----------------------|----|-----------------------------|--------------|---|----------------------------|-------------------------|--|--------|---------|
| PLANOS DE REFERENCIA | | MATERIAL | N° POR JUEGO | OBSERVACIONES Y ESPECIFICACION | INGENIEROS JEFES MECANICOS | | RETAINING RING FOR V.B. PISTON ROD GLAND (8FOR 1 3/4" DIAM. PISTONS) ANILLO DE RETENCION PARA GUARNICION DE VASTAGO DE FRENO A VACIO (1 3/4" DIAM- VASTAGO) | | |
| TITLE - TITULO | N° | BRASS LATON LAMINADO | | FA 8 714 (COPANT 16:2-025) Desig Cobre-Zinc 61-36, Plomo 3, semiduro | F.C.S. | | DATE | SCALE | |
| | | | | | F.C.O. | | | 1/7/36 | ESCALA: |
| | | | | | F.C.C.A. | | | FECHA: | EMISION |
| | | F.C.P. | | | COPY N° - COPIA N° | DRAWING N° DIBUJO N° | A.B.G.S. 732 | 3 | |

ES COPIA DEL DIBUJO NEFA 732
 M. BELLOCHIO - AREA INGENIERIA - C.N.R.T.
 E. 1:1