

OFFICE OF ORIGIN F.C. ....	DRAWN F.C. ....	TRACED F.C. ....	CHECKED F.C. ....
REVISED F.C.S. & F.C.O.	REVISED .C.C.A.		REVISED F.C.P.

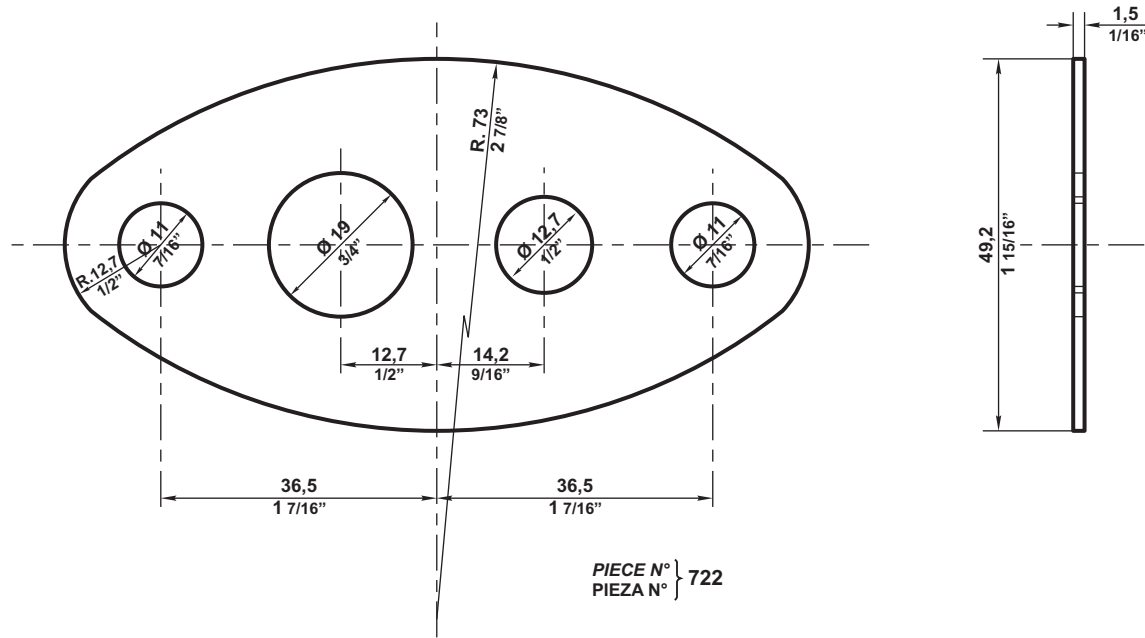

CADA JUNTA SE MARCARA SEGUN A.B.G.S. DIB. N° 707  
 EACH JOINT TO BE MARKED IN ACCORDANCE WITH A.B.G.S. DWG. N° 707

H.9/050/497/000/0

CAT. FV.75

EMISION 3: Se modificó especificación	REFERENCE PLANS		MATERIAL	N° PER SET	OBSERVATIONS & SPECIFICATION	CHIEF MECHANICAL ENGINEERS	ARGENTINE BOARD GAUGE STANDARD			
	PLANOS DE REFERENCIA		MATERIAL	N° POR JUEGO	OBSERVACIONES & ESPECIFICACION	INGENIEROS JEFES MECANICOS	JUNTA PARA VAL. DE AFLOJAMIENTO DE F.VACIO (CILINDROS TIPO ARO ROLLANTE)			
	TITLE - TITULO	N°	GOMA TIPO CLOROPRENO		FA. 8 403 (IRAM 113.001) 3 BC 7140 A.14 E.14	F.C.S.	DATE: 11/3/36 FECHA: 11/3/36		SCALE: ESCALA:	
						F.C.O.			DRAWING N° A.B.G.S. 722	
						F.C.C.A.			ISSUE EMISION 3	
		F.C.P.				DIBUJO N°				
						COPY N° - COPIA N°				

ES COPIA DEL PLANO NEFA 722  
 M. BELLOCHIO - GERENCIA DE SEGURIDAD - C.N.R.T.  
 E.1:1