

TOLERANCIAS NO ESPECIFICADAS
JS.15 = js.15

SIMBOLOS DE LABRADO
NO ESPECIFICADOS
S

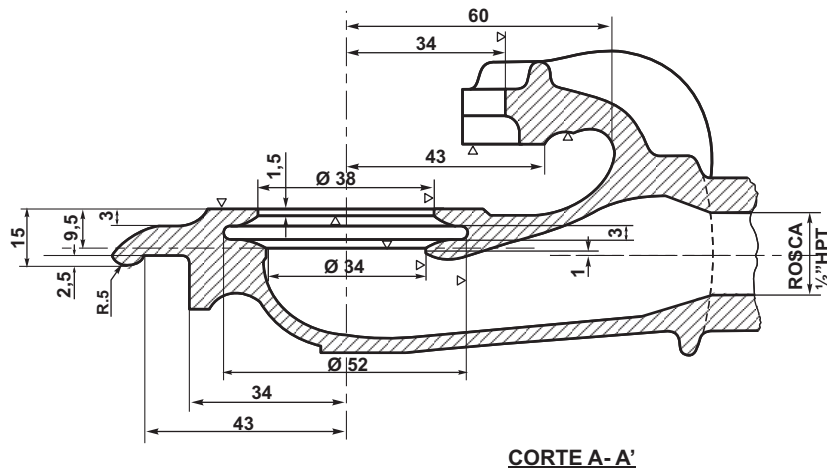
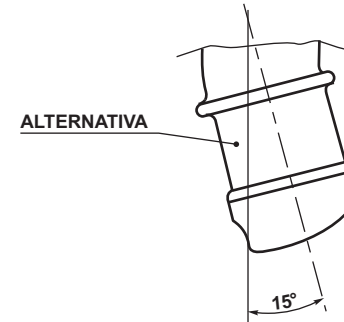
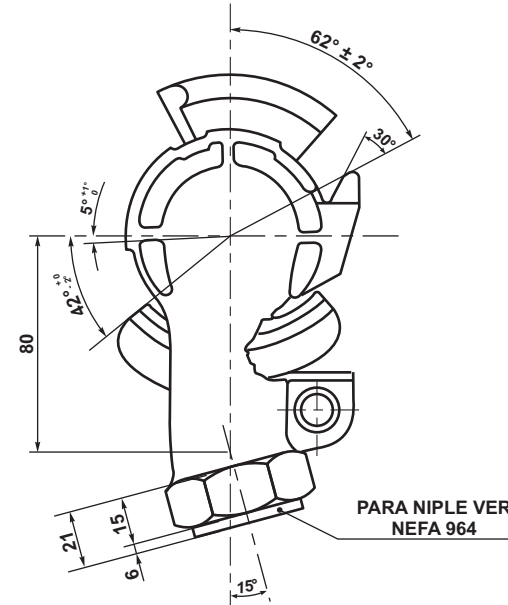
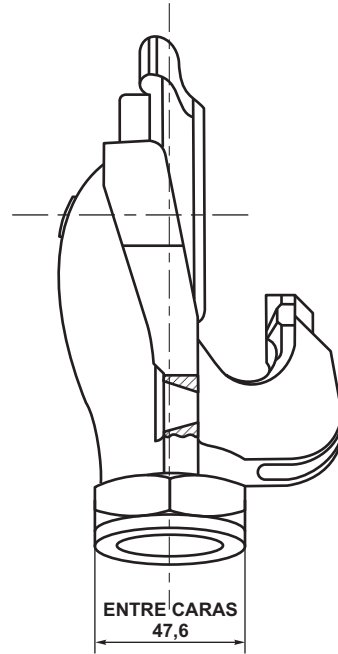
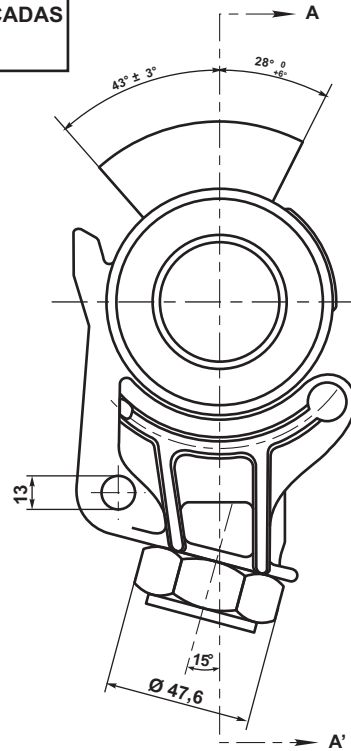

CORTE A-A'

EMISION	COTA	ALTERACIONES	FECHA - FIRMA
---------	------	--------------	---------------

FECHA: DIBUJO DIV. ESPECIFICACIONES DEPTO. TECNICA GERENTE MECANICA	FA. CAMBIASSO Ing. CRISTOBAL Ing. BATTAGLIA Ing. MARTINEZ	ITEM	DESCRIPCION	CANT.	ESCUADRIA, ESPECIFICAC. Y OBSERVACIONES	CATAL-NOMEN.
		EQUIPO DE ACCIONAMIENTO AUTOMATICO DE FRENO MANGA ECUALIZADORA DE CILINDRO DE FRENO Y COMANDO DE CILINDROS CABEZA DE ACOPLE				
ESCALA		TROCHA	LINEAS:		UTILIZACION	EMISION
FIRMA Y FECHA APROB.		N° DE PLANO		NEFA 653		1

ES COPIA DEL PLANO NEFA 653
M. BELLOCHIO - AREA INGENIERIA - C.N.R.T.