

Esc. 1:1

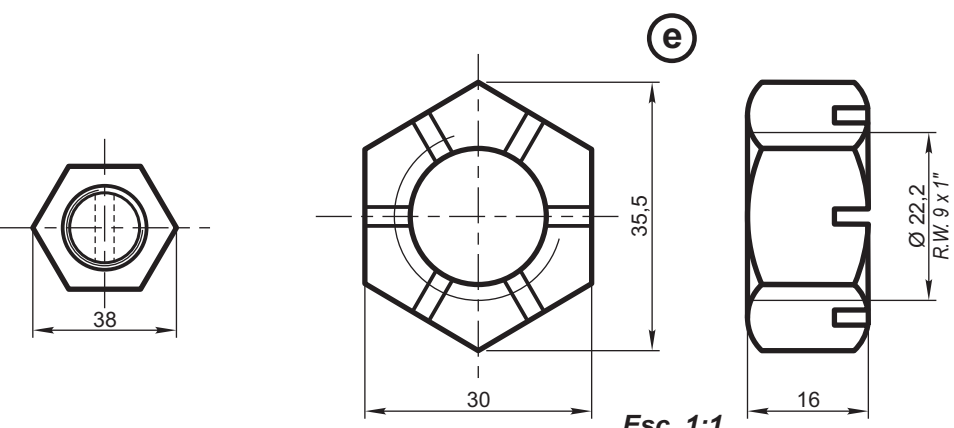

Esc. 1:1

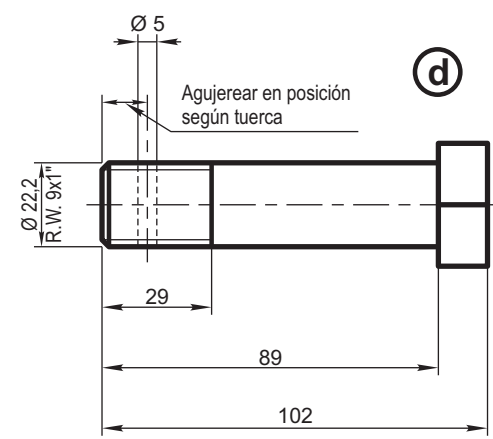
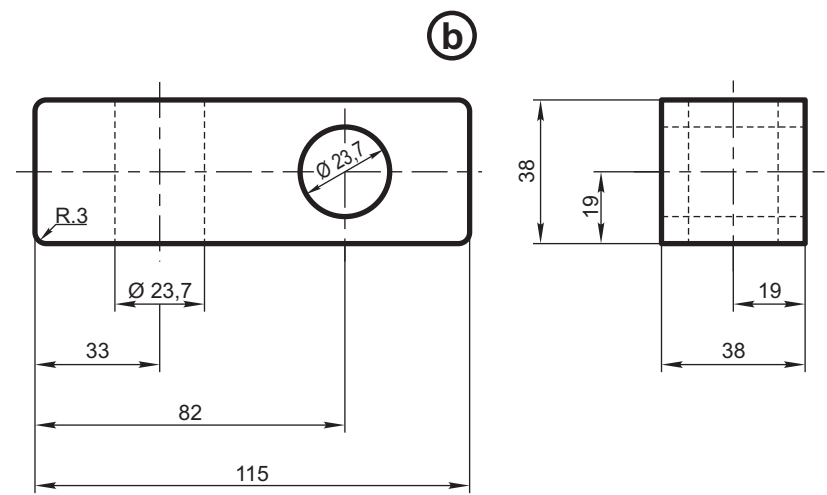
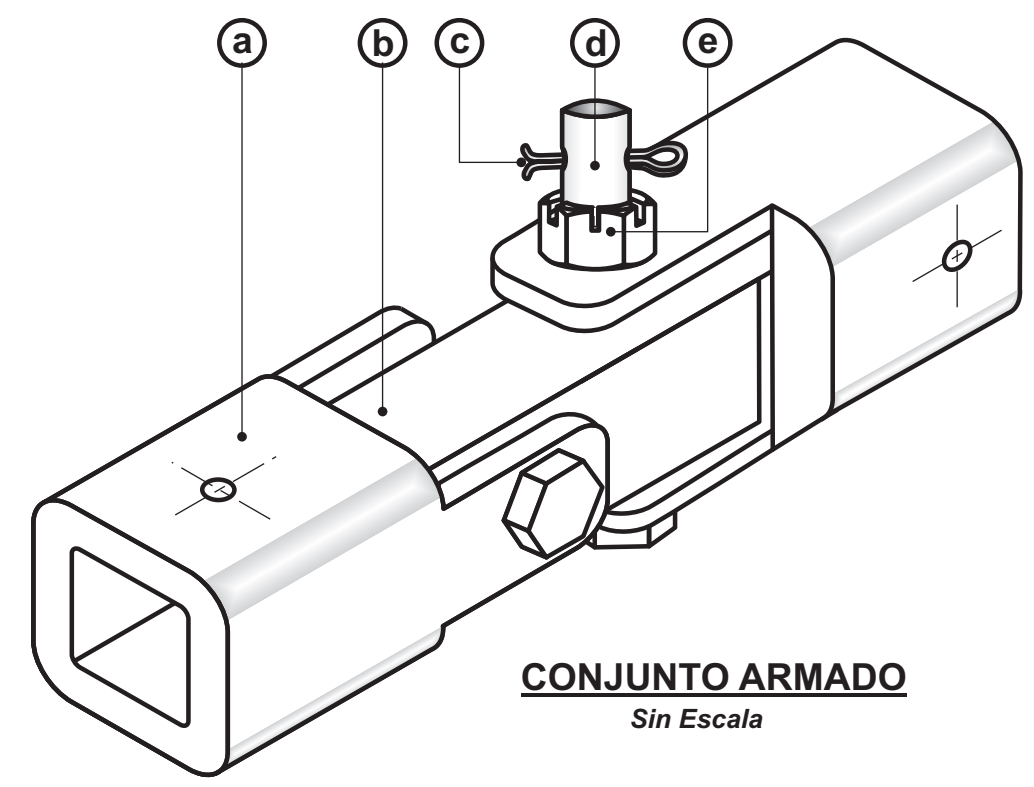

CONJUNTO ARMADO
Sin Escala

NOTAS:

LA MODIFICACION DEL ACOPLE CARDANICO SE REALIZARA EN LOS VAGONES TOLVAS PEDRERO SERIE 97.777 - 98.196 CONTRATO N° 1218.

PLANO NEFA N° 638/1, REALIZADO SEGUN CROQUIS T.A. N° 2189/1 DE TALLERES ALIANZA, F.C. SAN MARTIN

e	Tuerca Castillo	2	A.37 - IRAM 503	
d	Bulón de acople	2	A.37 - IRAM 503	
c	Pasador de aleta	2	A.37 - IRAM 503	
b	Barra Transmisión	1	A.37 - IRAM 503	
a	Cuerpo	2	A.37 - IRAM 503	
ITEM	DESCRIPCION	CANT.	ESCUADRIA, ESPECIFICACION Y OBSERVACIONES	CODIGO

ACOPLE CARDANICO MECANISMO DESCARGA			FERROCARRILES ARGENTINOS	
			AREA MECANICA	
ESCALA 1:1 - 1:2	TROCHA 1676	REGION: CENTRAL	UTILIZACION VAGONES TOLVA PEDREDO	EMISION 1
FIRMA Y FECHA APROB.		N° DE PLANO NEFA 638		