

OFFICE OF ORIGIN	F.C.S.	DRAWN	F.C.S.	TRACED	F.C.S.	CHECKED	F.C.S.
REVISED	FCS & FCC	REVISED	FCCA			REVISED	FCP

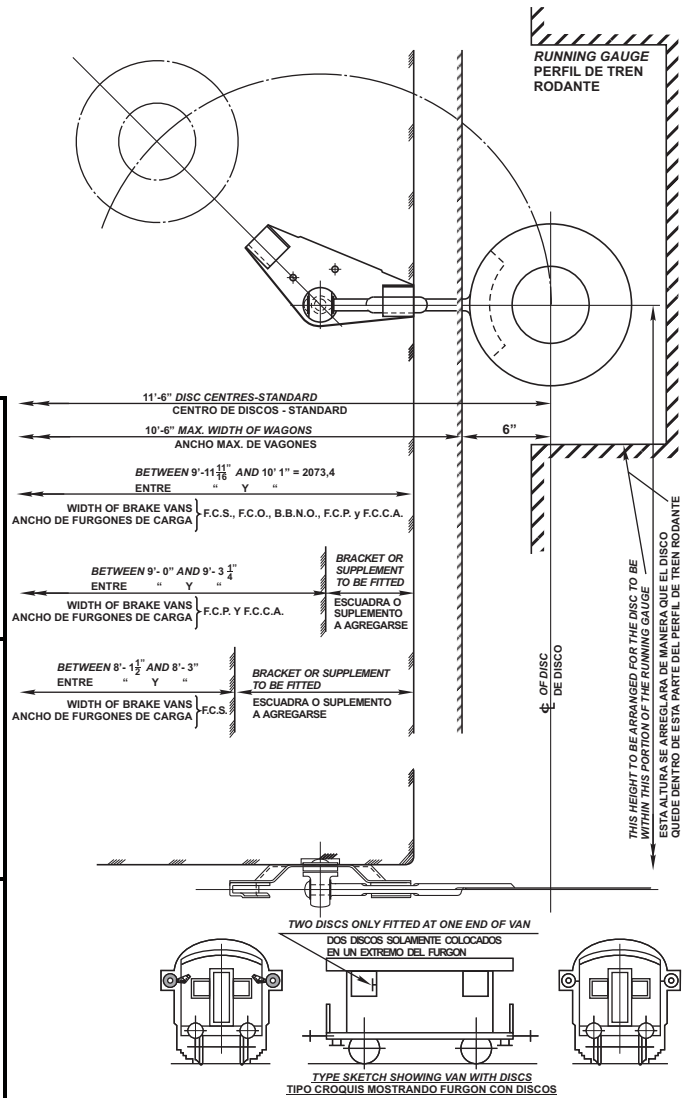

DETAIL OF WASHER
DETALLE DE LA ARANDELA
PIECE N° 426/B
PIEZA N° 426/B

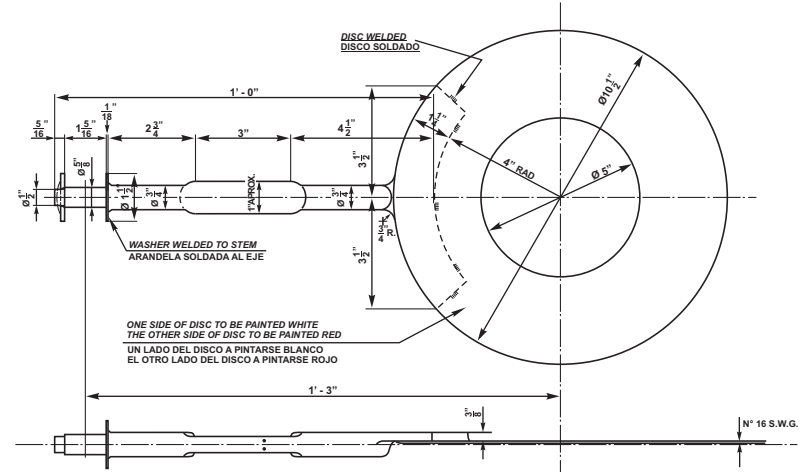

DETAIL OF DISC WITH STEM
DETALLE DEL DISCO CON EJE
PIECE N° 426/A
PIEZA N° 426/A

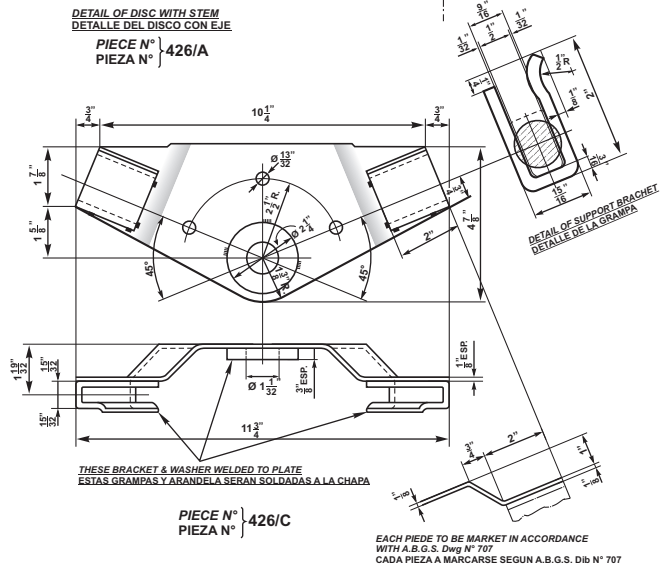
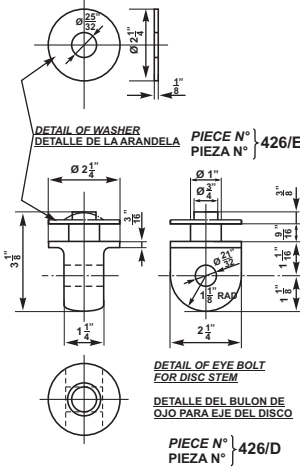

PREFERENCE PLANS		MATERIAL	N° PER SET	OBSERVATIONS & SPECIFICATION	CHIEF MECHANICAL ENGINEERS		ARGENTINE BROAD GAUGE STANDARD				
PLANOS DE REFERENCIA		MATERIAL	N° POR JUEGO	OBSERVACIONES Y ESPECIFICACION	INGENIEROS JEFES MECANICOS		TRAIN DISCS FOR CARGO BRAKE VANS DISCOS DE TREN PARA FURGONES DE CARGA				
TITLE - TITULO	N°	426 A 426 B 426 C 426 D 426 E			F.C.S. F.C.O.		DATE: FECHA:	SCALE: ESCALA:	COPY N° - COPIA N°	DRAWING N° DIBUJO N°	ISSUE. EMISION
		MILD STEEL ACERO DULCE			F.C.C.A.					426	1

ES COPIA DEL PLANO NEFA 426
M. BELOCHIO - AREA INGENIERIA - C.N.R.T.