

SIMBOLOS DE LABRADO NO
ESPECIFICADO ∇∇
IRAM 4517

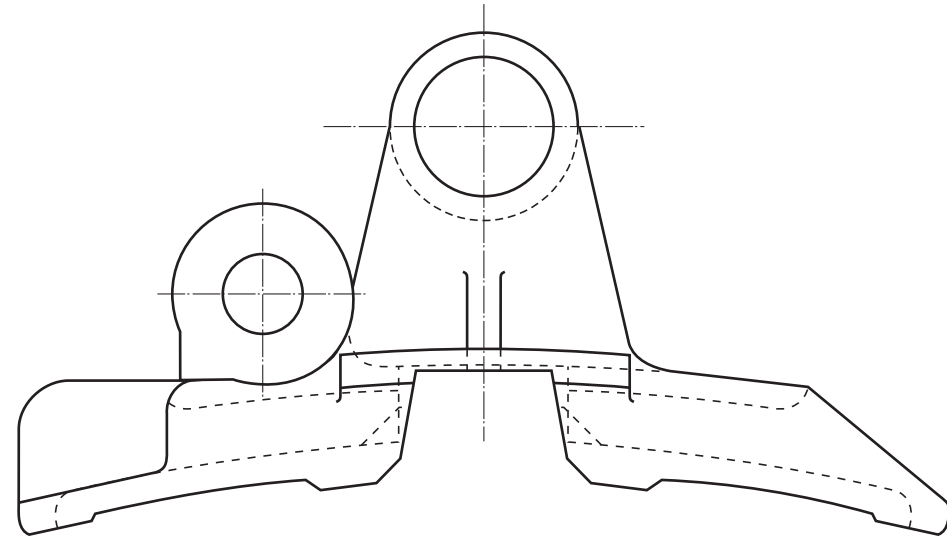

MATERIAL BUJE:
IRAM 600 - CLASE 1030/1040
NORMALIZADO

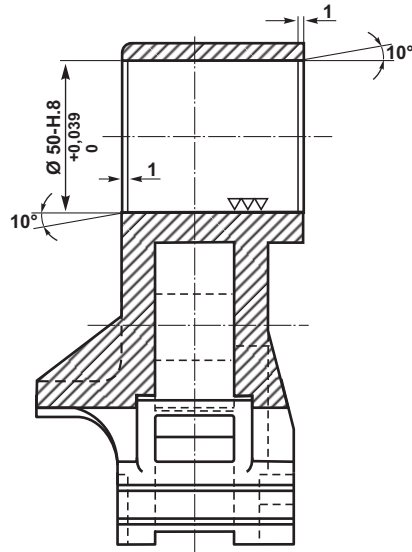
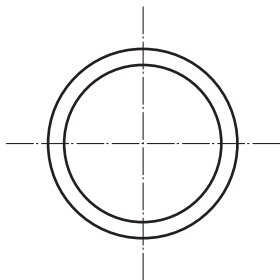
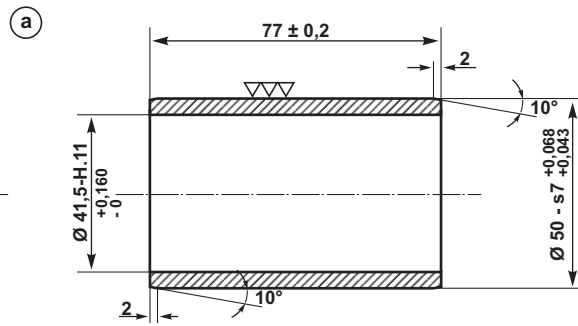

DISPOSICION GENERAL DE PORTA-ZAPATA
VER PLANO N° XF1.-16316/1 (F.C.MITRE)

EMISION	COTA	ALTERACIONES	FECHA-FIRMA
---------	------	--------------	-------------

F.A. CAMBIASSO	DIBUJO	Fch: 20/8/88	DIV. ESPECIFICAC.	DEPTO. TECNICA	GERENTE MECANICA	a	BUJE	1				
						ITEM	DESCRIPCION	CANT.	ESCUAD.ESP.OBSERVAC.	CATAL-NOMEN		
						BUJE PARA PORTA-ZAPATA DE FRENO - BOGIE LIBRE Y ACOPLADO					 AREA: MECANICA	
						ESCALA	TROCHA: 1676	LINEAS: MITRE	UTILIZACION COCHES ELECT. INGLESES	EMISION		
FIRMA Y FECHA APROB.						N° DE PLANO: NEFA 423		1				

ES COPIA DEL PLANO NEFA 423
 M. BELLOCHIO - AREA INGENIERIA - C.N.R.T.