

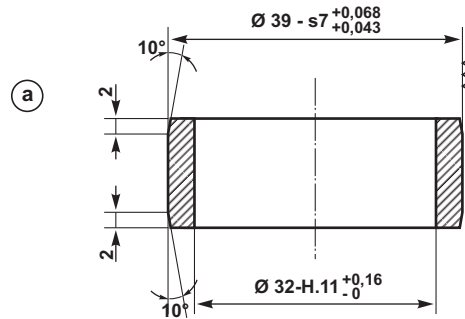

SIMBOLOS DE LABRADO NO  
ESPECIFICADO ∇∇  
IRAM 4517

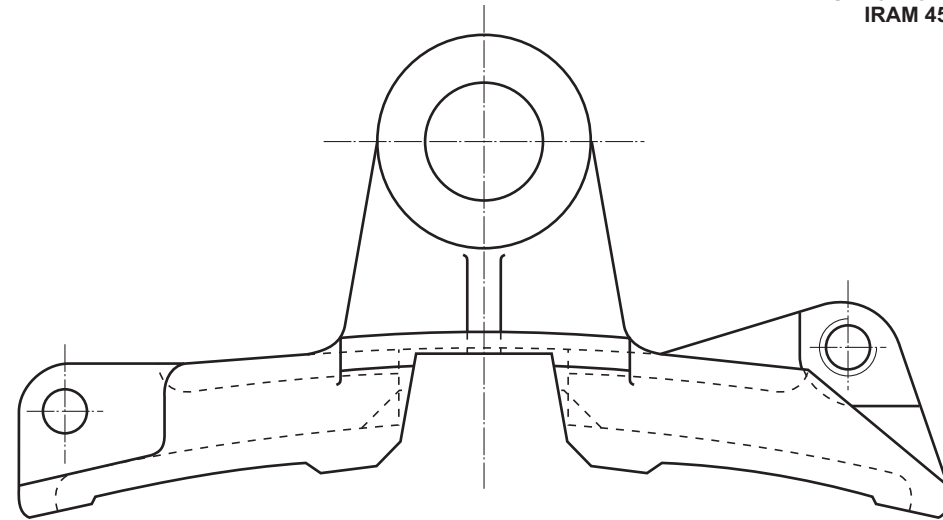
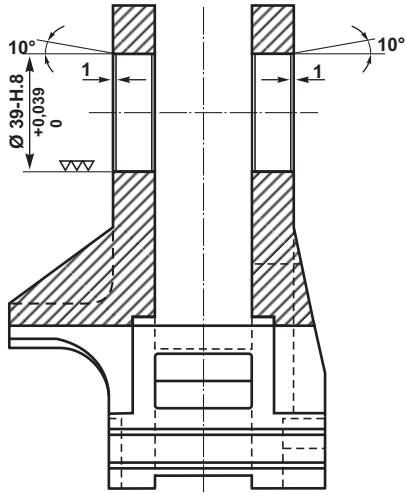

**MATERIAL BUJES:**  
**IRAM 600 - CLASE 1030/1040**  
**NORMALIZADO**

**DISPOSICION GENERAL DE PORTA-ZAPATA**  
**VER PLANO N° XF1.-15690/1 /F.C.MITRE)**

EMISION	COTA	ALTERACIONES	FECHA-FIRMA
---------	------	--------------	-------------

F.A. CAMBIASSO	DIBUJO	FECHA: 19/8/88	DIV. ESPECIFICAC.	DEPTO. TECNICA	GERENTE MECANICA	a	BUJE	2				
						ITEM	DESCRIPCION	CANT.	ESCUAD.ESP.OBSERVAC.	CATAL-NOMEN		
						BUJES PARA PORTA-ZAPATA DE FRENO BOGIE MOTOR					 AREA: MECANICA	
						ESCALA	TROCHA: 1676	LINEAS: MITRE	UTILIZACION COCHES ELECT. INGLESES	EMISION		
FIRMA Y FECHA APROB.						N° DE PLANO: NEFA 422		1				

**ES COPIA DEL PLANO NEFA 422**  
M. BELLOCHIO - AREA INGENIERIA - C.N.R.T.