

CORTE A-A

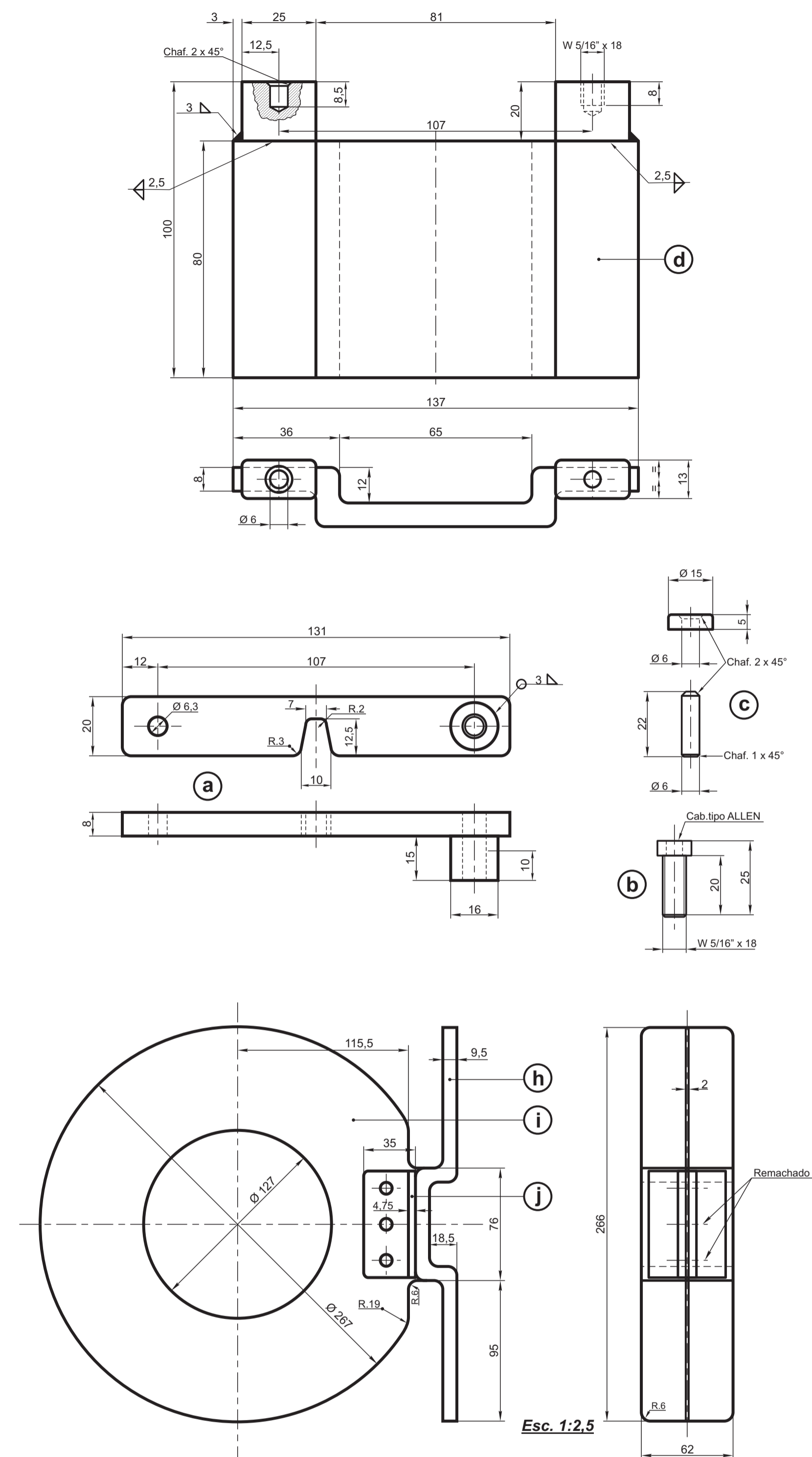
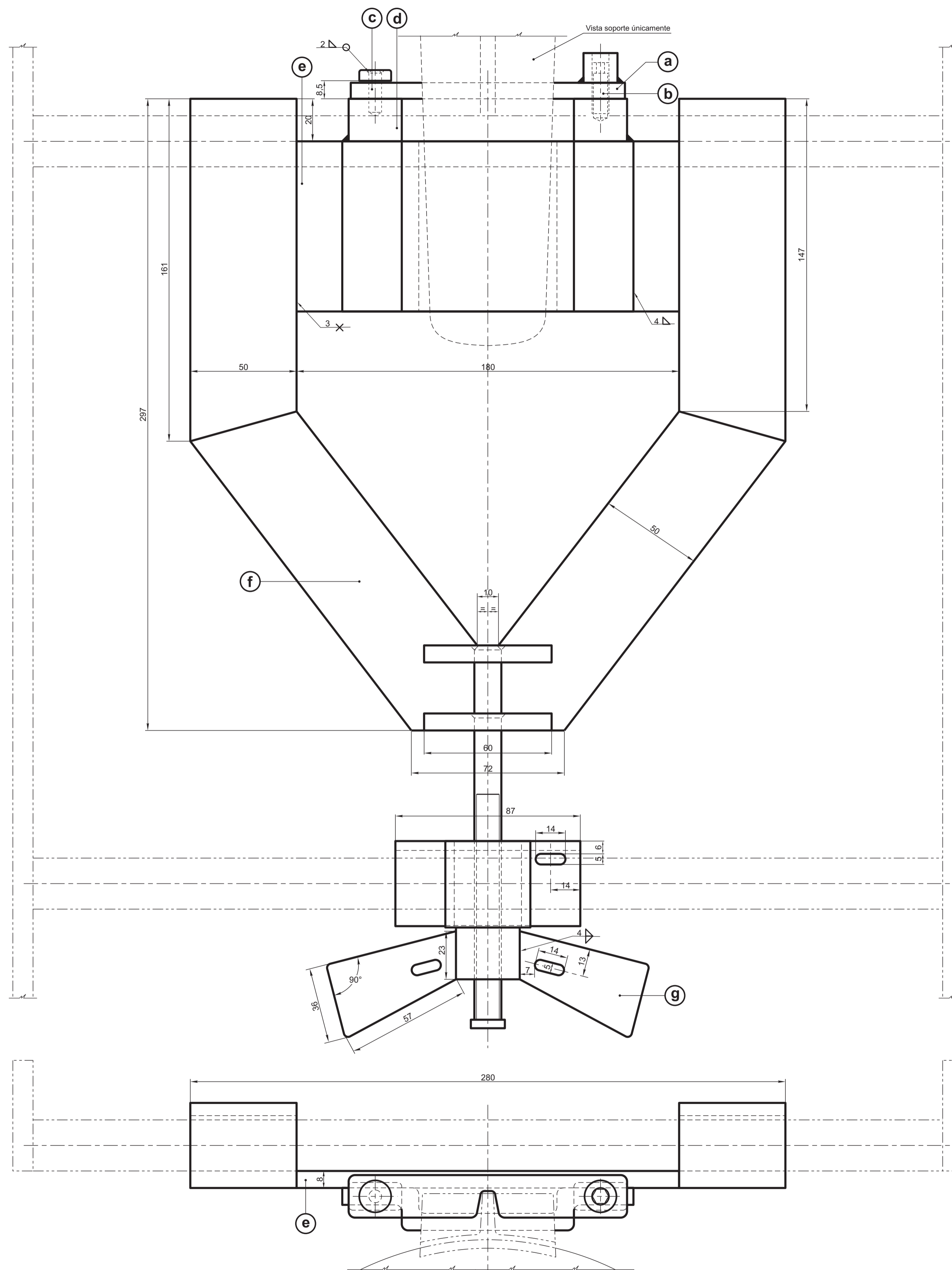

ITEM	DESCRIPCION	Cant.	ESCUADRIA, ESPECIFICAC. Y OBSERVACIONES	CATAL-NOMEN.
j	Escuadra refuerzo	2		
i	Disco señal	1		
h	Soporte disco	1		
g	Tuerca ajuste conjunto	1		
f	Conjunto soporte a fijar escalera	1		
e	Chapa refuerzo	1		
d	Soporte farol	1		
c	Perno y arandela fijación	1		
b	Tornillo cabeza tipo Allen	1		
a	Chapa seguro	1		

DISPOSITIVO SUJECION FAROL DE COLA SOBRE ESCALERA LATERAL DE VAGON

FERROCARRILES ARGENTINOS
AREA MECANICA

ESCALA	TROCHA	LINEAS	UTILIZACION	EMISION
1:1,25	1676			1
FIRMA Y FECHA APROB.			Nº DE PLANO	
			NEFA 420	