

CORTE H-H

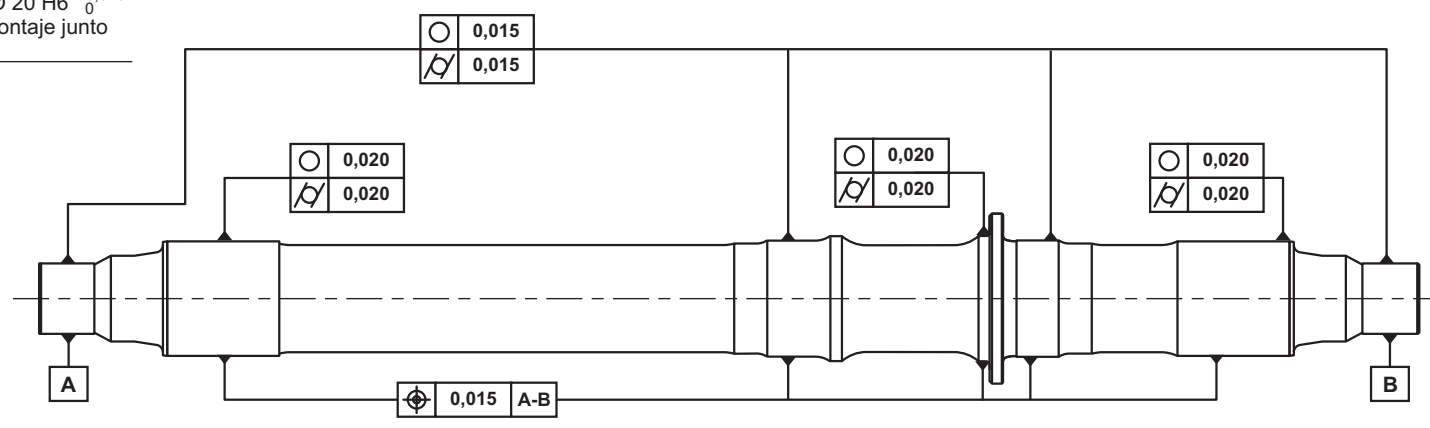

TOLERANCIAS DE FORMA GEOMETRICA



Rugosidad de superficie: $\sqrt{\quad}$ IRAM 4537

Marcado del eje: NEFA 249

Para detalles C, D y E y vista del extremo del eje ver NEFA 270

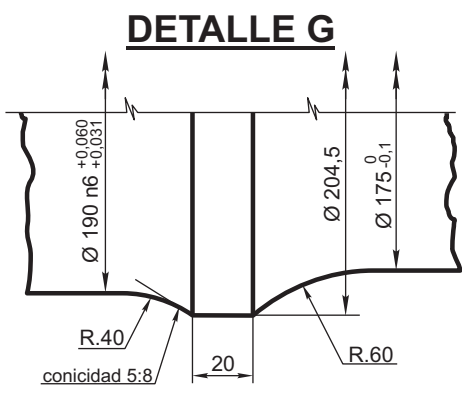
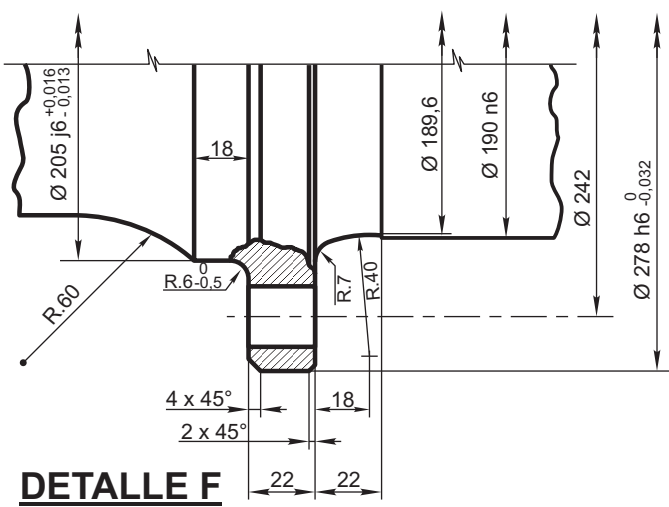
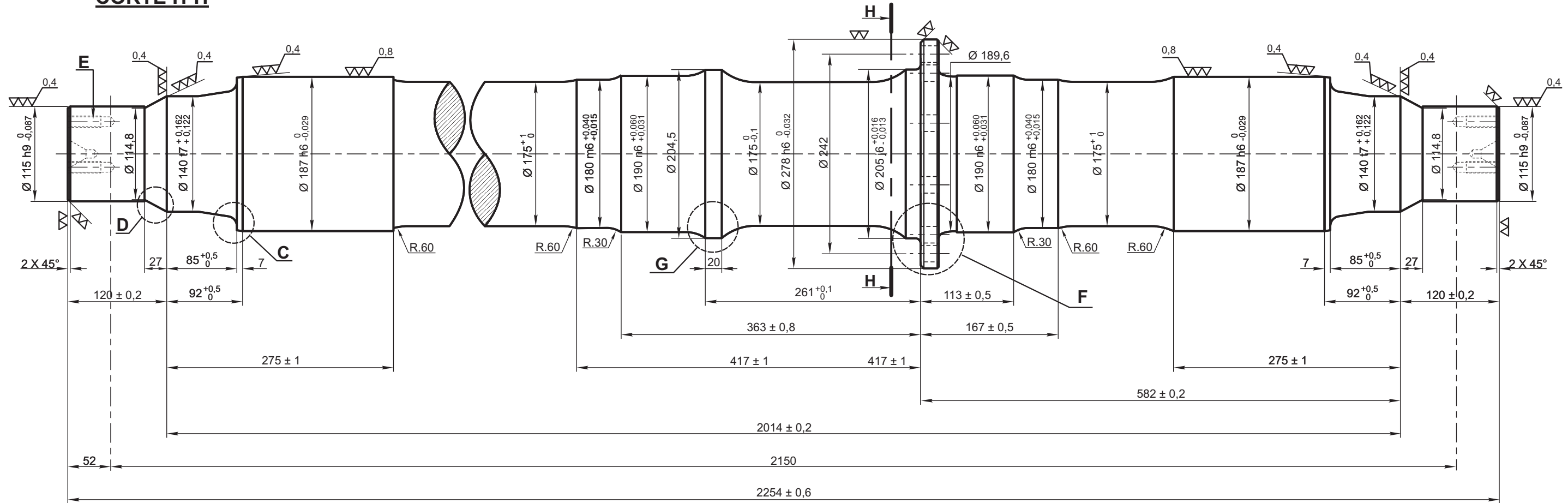

Eje motriz debajo motor diesel		AAR-M 101-68 Grado F		3/05/1/01/0059	
ITEM	DESCRIPCION	Cant.x Coche	ESCUADRIA, ESPECIFICAC. Y OBSERVACIONES	CATAL-NOMEN.	
EJES MOTRIZ Debajo motor diesel BOGIES MOTRICES				FERROCARRILES ARGENTINOS	
				AREA MECANICA	
ESCALA 1:5 1:2,5	TROCHA 1676	LINEAS: GRAL. SAN MARTIN	UTILIZACION T.D. GANZ MAYAG	EMISION	
FIRMA Y FECHA APROB.			N° DE PLANO NEFA 267		1