

11/16" DRILLED HOLES FOR 5/8" RIVETS
 AGUJEROS DE 17,5 PARA REMACHES DE Ø 16

PIECE N° } 188/A
 PIEZA N° }

MATERIAL: ACERO FUNDIDO
 ESPECIFICACION:
 FA.8701 (IRAM 7026)
 CLASE: B

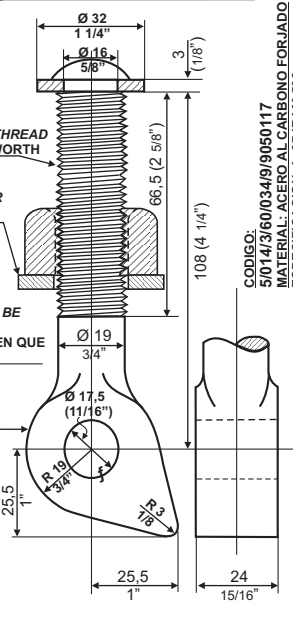
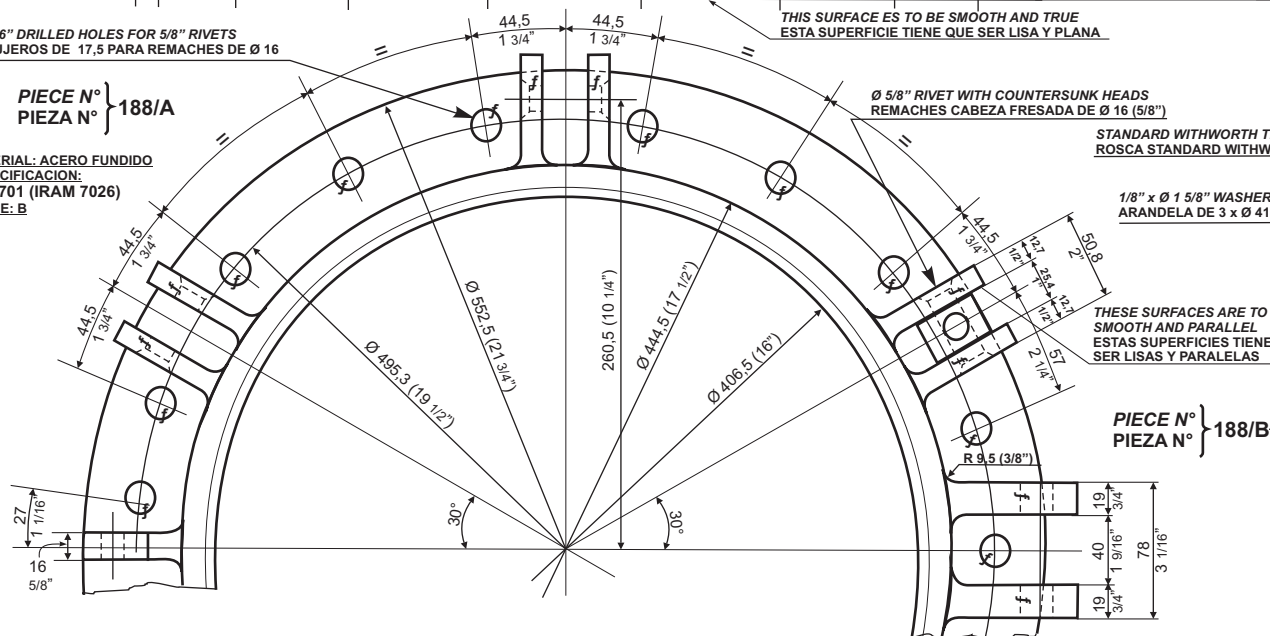

CODIGO:
 5101413/60/034/9/9050117
 MATERIAL: ACERO AL CARBONO FORJADO
 ESPECIFICACION: A. 37 IRAM 538

EACH LED TO BE MARKED IN ACCORDANCE WITH A.B.G.S. DRG. N° 707
 CADA TAPA SE MARCARA SEGUN A.B.G.S. DIB. N° 707

NOTE: f INDICATES MACHINE FINISH
 NOTA: f INDICA TERMINADO A MAQUINA

OFFICE OF ORIGIN	FCCA	DRAWN	FCCA	TRACED	FCCA	CHECKED	FCCA
REVISED	FCS & FCCO	REVISED	FCCA	REVISED	FCCA	REVISED	FCP

PREFERENCE PLANS		MATERIAL	N° PER SET	OBSERVATIONS & SPECIFICATION	CHIEF MECHANICAL ENGINEERS		ARGENTINE BROAD GAUGE STANDARD			
PLANOS DE REFERENCIA		MATERIAL	N° POR JUEGO	OBSERVACIONES Y ESPECIFICACION	INGENIEROS JEFES MECANICOS		DOME RING. TANK WAGONS ANILLO DEL DOMO. VAGONES TANQUE			
TITLE - TITULO	N°				F.C.S.		DATE:	SCALE:		
DOME LID TAPA PARA DOMO	A.B.G.S. 187	188/A CAST STEEL ACERO FUNDIDO	1	EN CASO DE SOLICITARSE SOLDADA AL TANQUE, EL ALA DE REMACHADO DEBE SER ELIMINADA.	F.C.O.		22/04/38			
		188/B MEEL STEEL ACERO DULCE	6		F.C.C.A.					
							COPY N° - COPIA N°	DRAWING N° DIBUJO N°	A.B.G.S. 188	ISSUE. EMISION
										2

ES COPIA DEL PLANO NEFA 188
 M. BELOCHIO - AREA INGENIERIA - C.N.R.T.