

OFFICE OF ORIGIN	FCCA	DRAWN	FCCA	TRACED	FCCA	CHECKED	FCCA
REVISED	FCS & FCC	REVISED	FCCA			REVISED	FCP

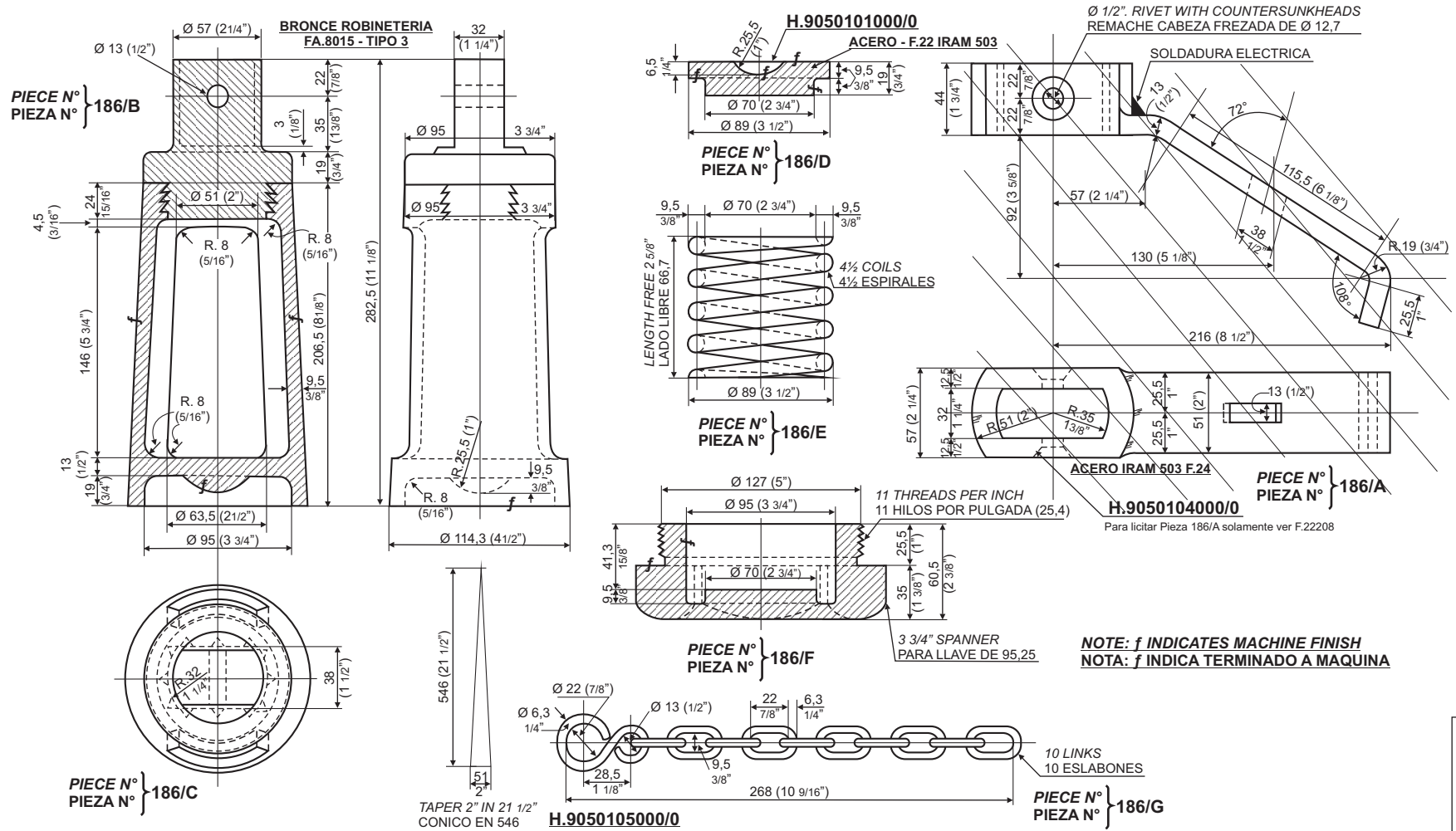

PREFERENCE PLANS		MATERIAL	N° PER SET	OBSERVATIONS & SPECIFICATION	CHIEF MECHANICAL ENGINEERS	ARGENTINE BROAD GAUGE STANDARD					
PLANOS DE REFERENCIA		MATERIAL	N° POR JUEGO	OBSERVACIONES Y ESPECIFICACION	INGENIEROS JEFES MECANICOS	SIDE DISCHARGE VALVE. DETAILS TANK WAGONS VALVULA DE DESCARGA LATERAL. DETALLES VAGONES TANQUES					
TITLE - TITULO	N°				F.C.S. F.C.O.	DATE: 10/11/48	SCALE: ESCALA:				
SIDE DISCHARGE VALVE. VALVULA DE DESCARGA LATERAL	A.B.G.S. 184	186/A MILD STEEL ACERO DULCE		AL PARTS TO BE MARKED IN ACCORDANCE WITH A.B.G.S. DRG. N° 707  TODAS LAS PIEZAS SE MARCARAN SEGUN A.B.G.S. DIB. N° 707		F.C.C.A.	COPY N° - COPIA N°	DRAWING N° DIBUJO N° <b>186</b>	ISSUE. EMISION <b>2</b>		
		186/C CAST BRONZE OR CAST IRON BRONCE FUNDIDO O HIERRO FUNDIDO									
		186/B MILD STEEL ACERO DULCE									
					186/E SPRING STEEL ACERO ELAT.						
					186/D MILD STEEL ACERO DULCE						
					186/F MILD STEEL ACERO DULCE						
					186/G MILD STEEL ACERO DULCE			F.C.P.			

**ES COPIA DEL PLANO NEFA 186**  
 M. BELOCOCHIO - AREA INGENIERIA - C.N.R.T.