

ARANDELA CUÑA

ESPECIFICACIONES:
SEGUN NORMA IRAM-FA L 7006 Y COMPLEMENTARIAS

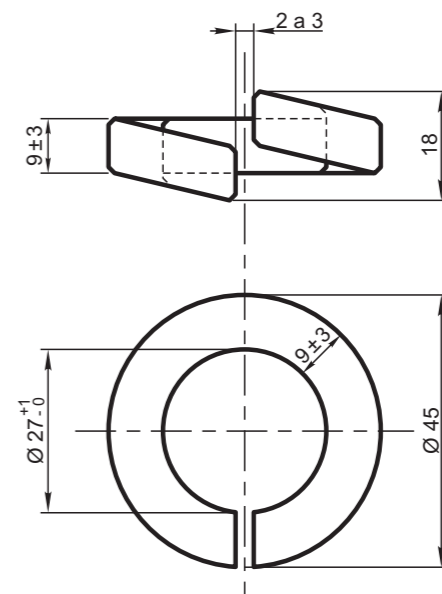

**ARANDELA ELASTICA
PARA BULON Ø 25,4**

ESPECIFICACIONES:
SEGUN NORMA IRAM-FA L 7008

NOTAS:

- 1) TODAS LAS COTAS ESTAN INDICADAS EN MILIMETROS.
- 2) ESTOS ACCESORIOS CORRESPONDEN A CORAZONES DE PLANOS G.V.O. 801 Y G.V.O. 802 (Diseño especial)

Tg. 1:8			Tg. 1:10		
CANT.	L	L'	CANT.	L	L'
2	90	65	2	90	65
1	175	76	1	175	76
2	200	76	2	200	76
1	225	76	1	225	76
4	275	76	2	250	76
2	300	76	4	275	76
2	350	76	1	325	76
1	425	76	1	350	76
1	450	76	1	400	76
			1	425	76

**BULON Ø 25,4 PARA CORAZON AGUDO
Tg. 1:8 Y Tg. 1:10 (Diseño especial)**

RIEL U.36 BULON Ø 25,4 ARANDELA CUÑA ARANDELA ELASTICA				FERROCARRILES ARGENTINOS	
				AREA VIA Y OBRAS	
ESCALA 1:1,25	TROCHA TODAS	LINEAS: TODAS	UTILIZACION	EMISION	
FIRMA Y FECHA APROB.			Nº DE PLANO G.V.O. 842	1	