

(A)  
(Esc. 1:1)

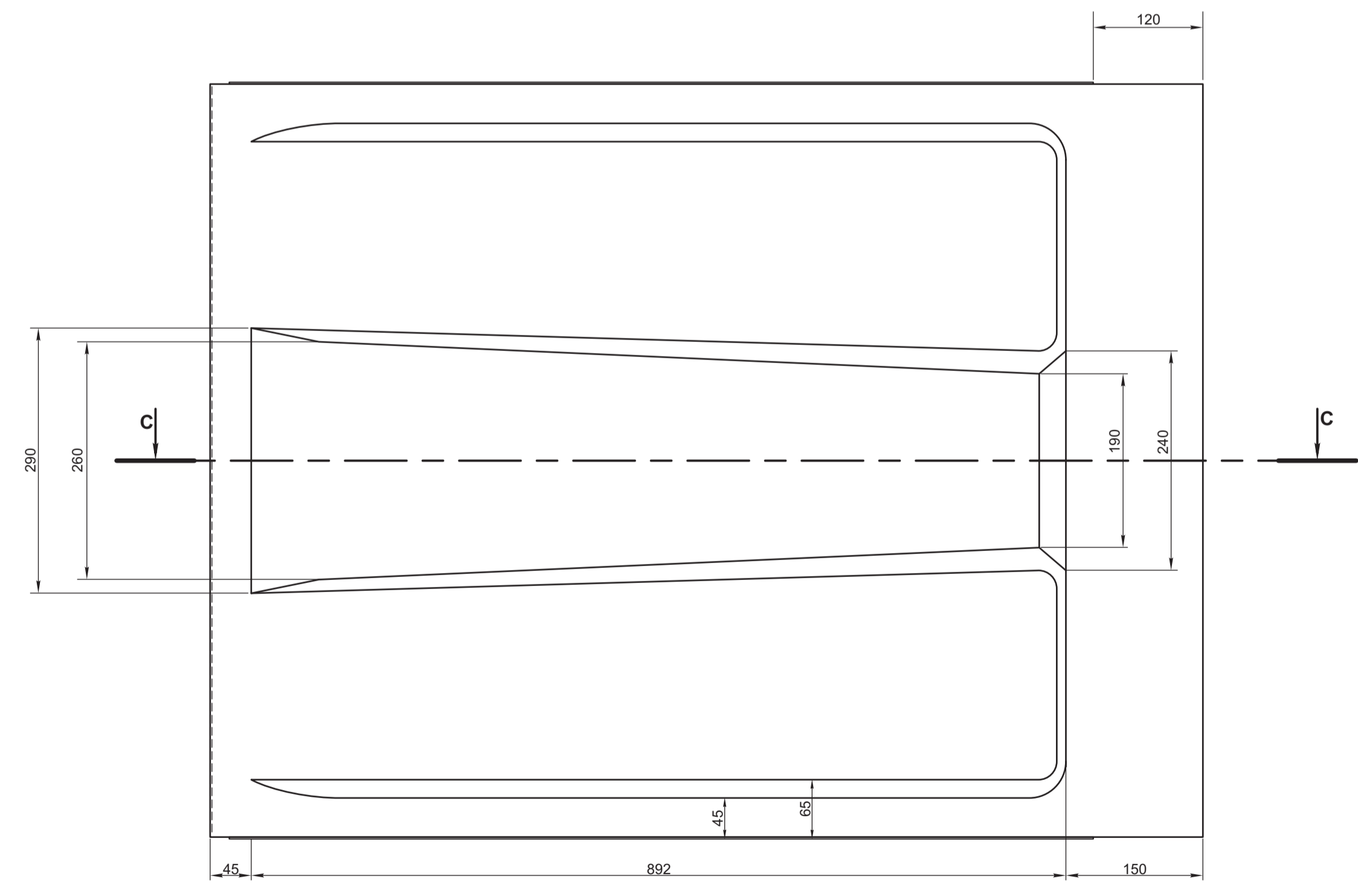

(C)

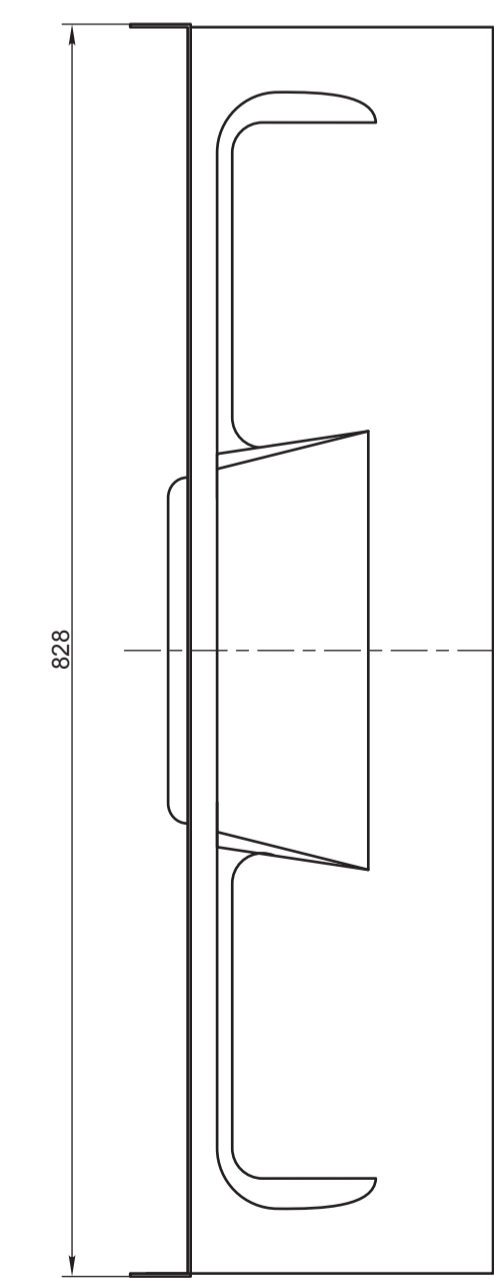
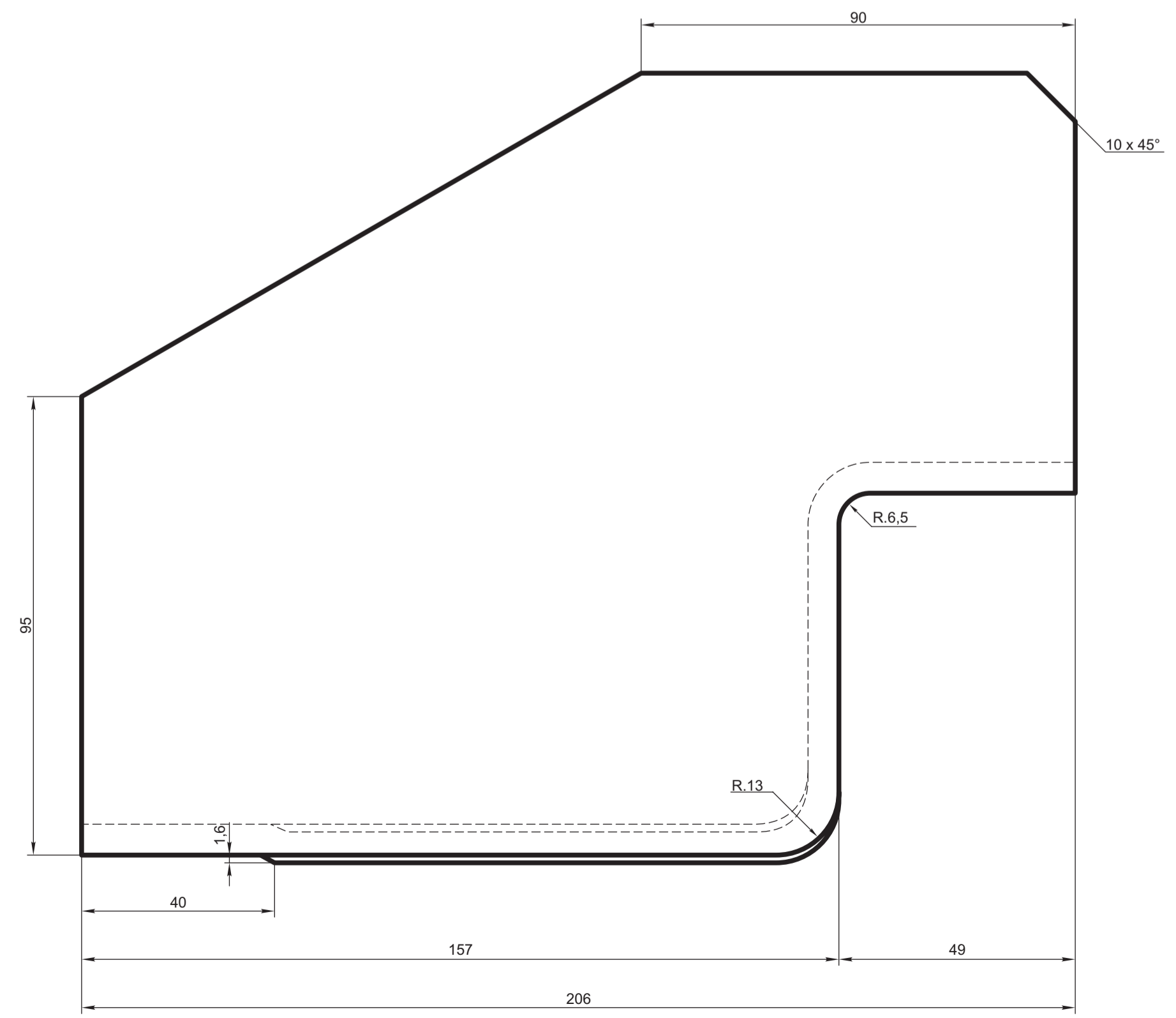
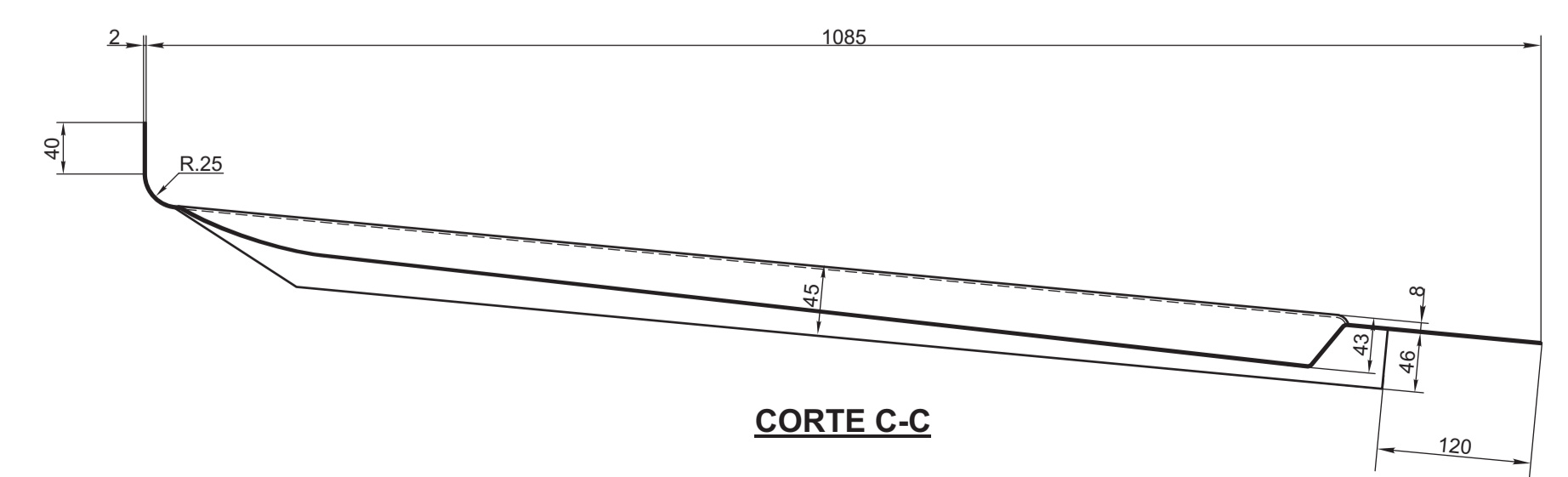

CORTE C-C

ITEM	DESCRIPCION	CANTIDAD	ESPECIFICACION	CATAL. NOMEN.
C	Panel intermedio boca	1	UIC 843 - 2R. SOL. 0.25 A 0.40% Cu Galv.	
B	Panel extremo boca	1	UIC 843 - 2R. SOL. 0.25 A 0.40% Cu Galv.	
A	Esquinero	1	UIC 843 - 2R. SOL. 0.25 A 0.40% Cu Galv.	

ZANELLA		FERRUCARILES ARGENTINOS	
Escala		AREA MECANICA	
TROCIA		VAGONES	
LINEAS		EMISION	
UTILIZACION		N° DE PLANO	
FIRMA Y FECHA APROB.		NEFA 29.002	