

TOLERANCIAS GENERALES

PIEZAS USINADAS	± 0,25 mm
PIEZAS FORJADAS	± 0,8 mm
PIEZAS EN CHAPAS	± 0,5 mm
ANGULOS	± 0,30°
MATAR CANTOS VIVOS	

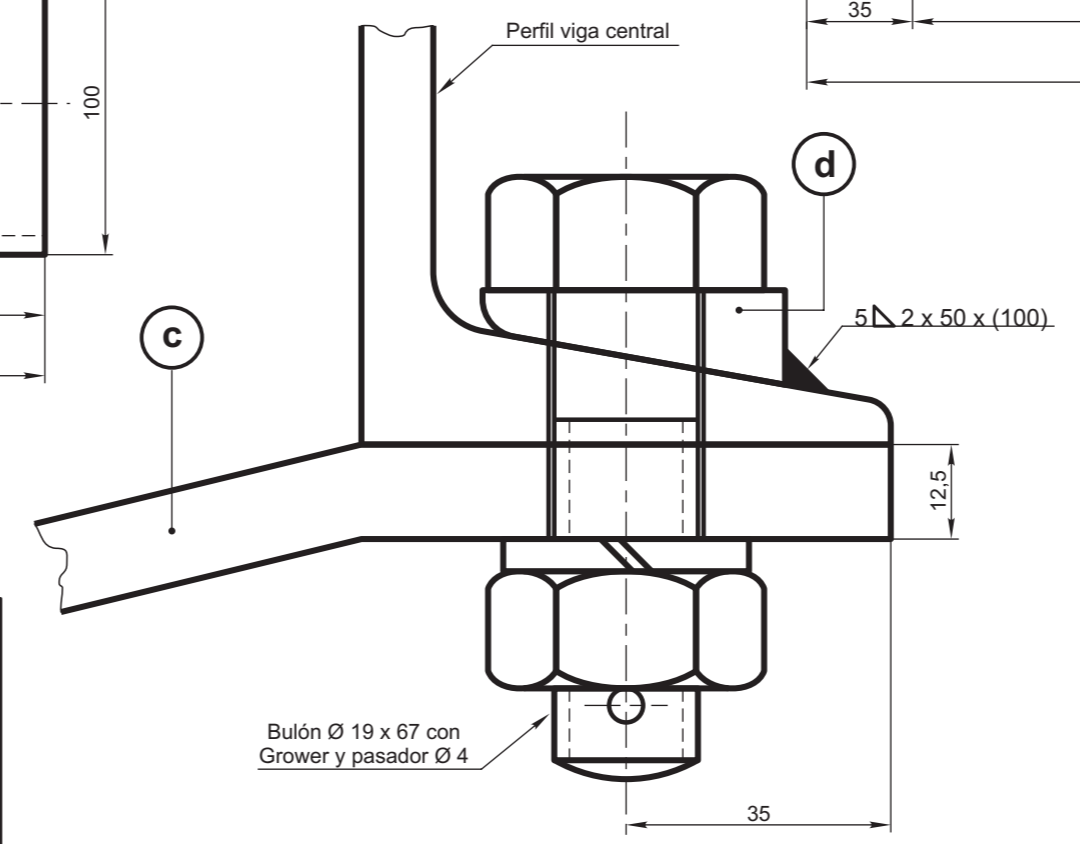

Detalle sujeción soporte yugo
Esc. 1:1

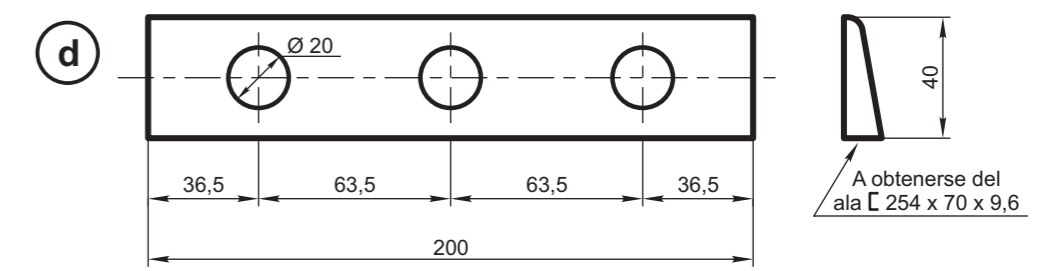

A obtenerse del ala L 254 x 70 x 9,6

ITEM	DESCRIPCION	Cant.	ESCUADRIA, ESPECIFICAC. Y OBSERVACIONES	CATAL-NOMEN.
d	Cuña	4		
c	Soporte yugo	2	≠ 12,5 Calidad Comercial	
b	Chapa fricción	2	≠ 6,3 IRAM 1070-53	
a	Soporte enganche	2	L 100 x 50 x 6 Calidad Comercial	

VAGON TANQUE MONOCASCO 45 m³

SOPORTES EQUIPO TRACCION

FERROCARRILES ARGENTINOS

AREA
MECANICA

ESCALA 1:2,5	TROCHA 1000	LINEAS:	UTILIZACION	EMISION
FIRMA Y FECHA APROB.			Nº DE PLANO NEFA 25.007	1