

(a)
DISPOSICION GENERAL

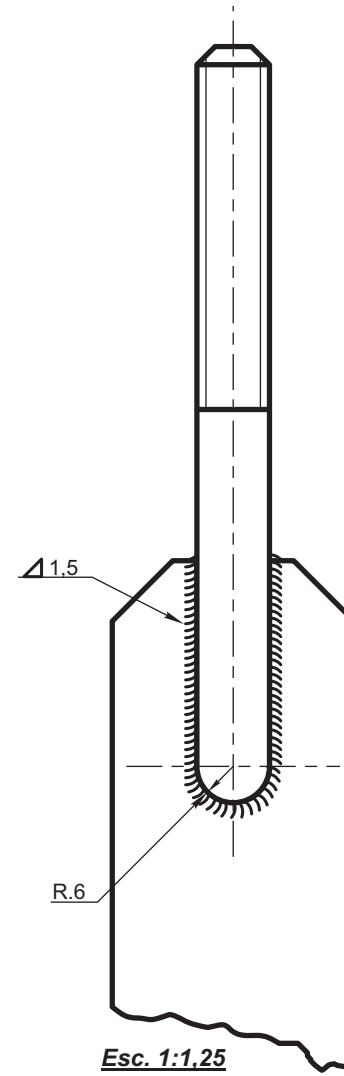

Esc. 1:1,25

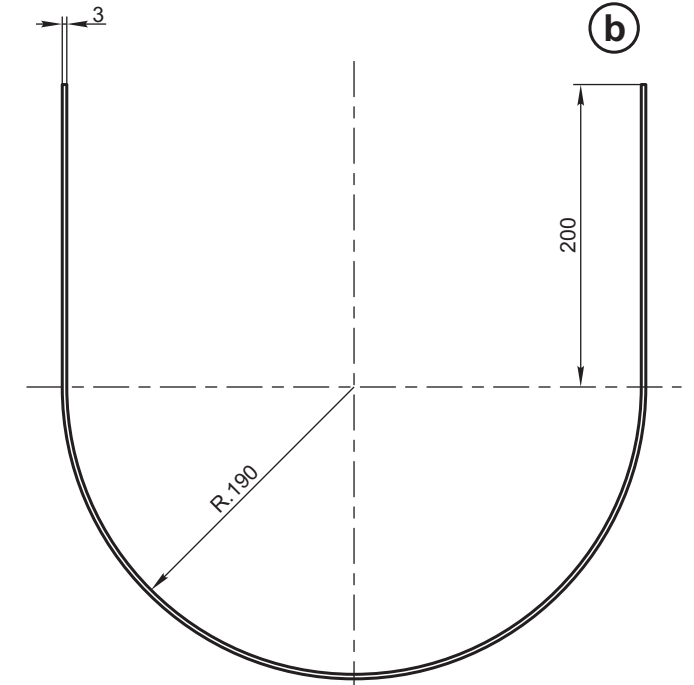
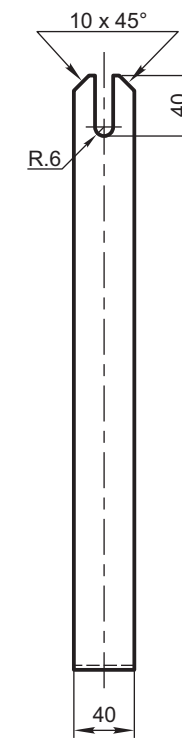

Esc. 1:5

CAT. FABRICA 5.86.0.16 444028

f	Contratuercia hexagonal		M12 x 1,5 Acero SAE 1015 - 1020	9023098000/0
e	Tuerca hexagonal		M12 x 1,5 Acero SAE 1015 - 1020	8068365080/0
d	Arandela plana de Ø 13 mm		Arandela 11E/IRAM 5107	8911031025/0
c	Extremo roscado		Acero SAE 1015 - 1020	9023097000/0
b	Envoltura		Acero SAE 1010 - 1015	9023096000/0
a	Abrazadera para fijación de depósito completa			9023095000/0
ITEM	DESCRIPCION	Cant.	ESCUADRIA, ESPECIFICACION, OBSERVAC.	CATAL.NOM.

**ABRAZADERA
DEPOSITO AUXILIAR PARA FRENO A VACIO**

**FERROCARRILES
ARGENTINOS**

AREA
MECANICA

NOTA:

LA COMPRA INDIVIDUAL DEL ITEM f SE EFECTUARA POR DESCRIPCION CON TARJETA DE ESPECIFICACION

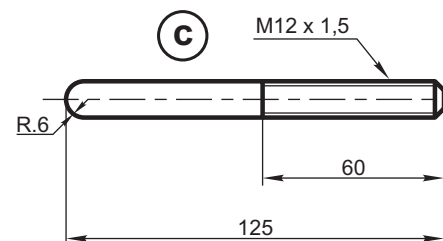

ESCALA 1:2,5	TROCHA 1676	LINEAS: SAN MARTIN	UTILIZACION COCHES MATERFER	EMISION 1
FIRMA Y FECHA APROB.			Nº DE PLANO NEFA 2-73-3-5051	