

PARA SIMBOLOS DE SOLDADURA VER IRAM 4536
TOLERANCIA ENTRE CENTRO DE AGUJEROS ± 0,2

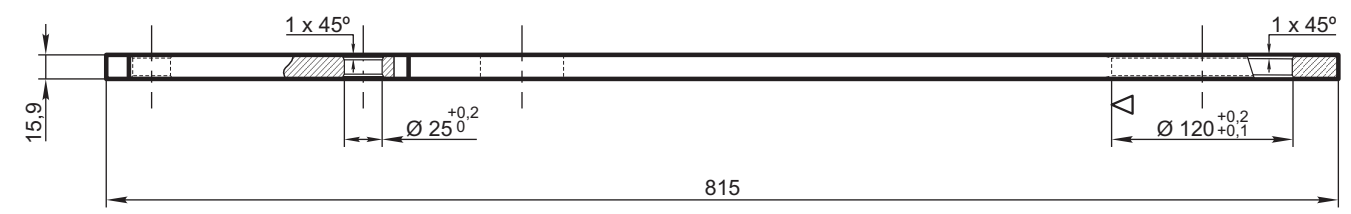
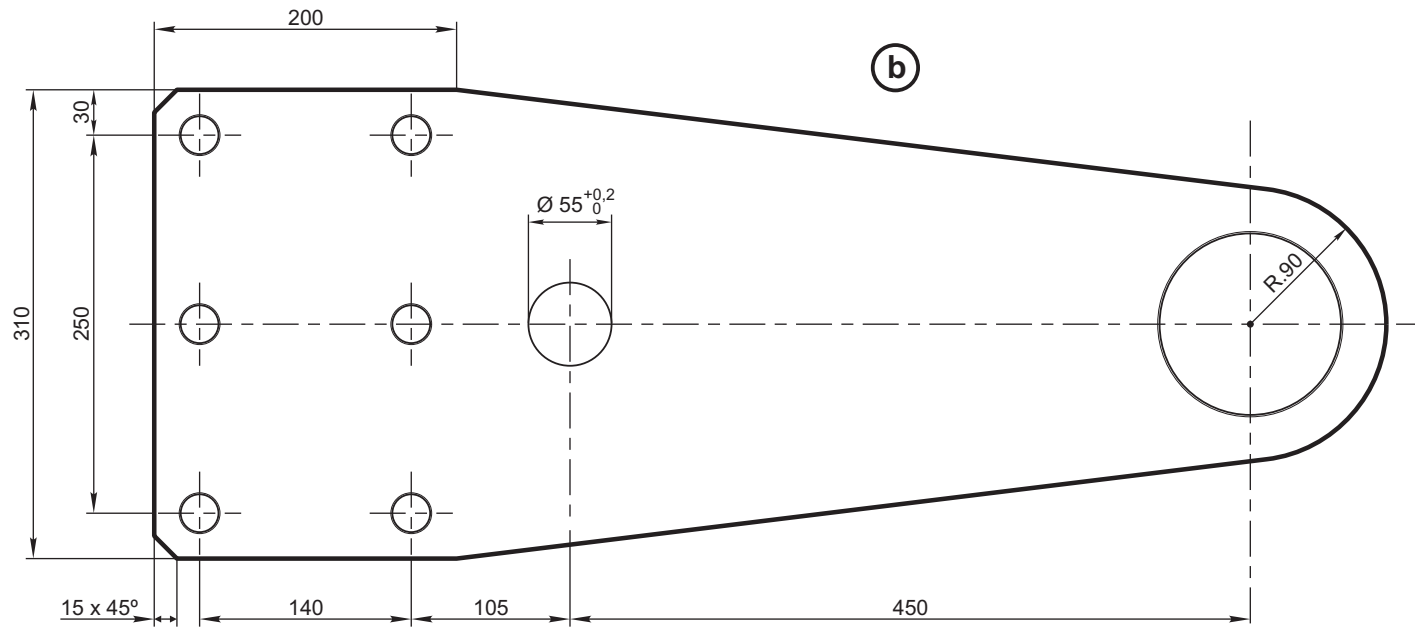
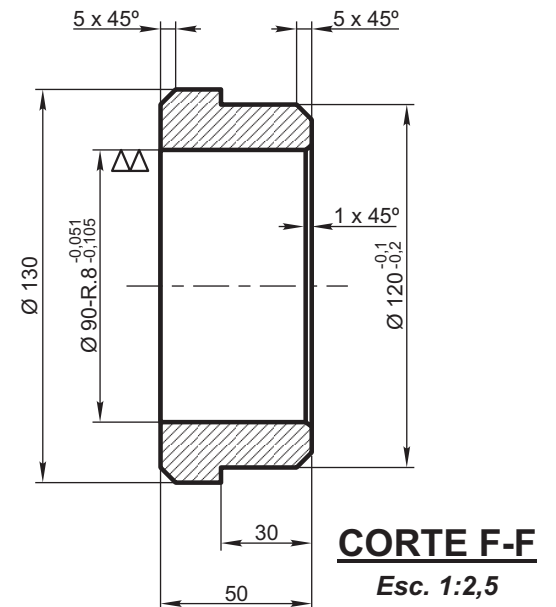
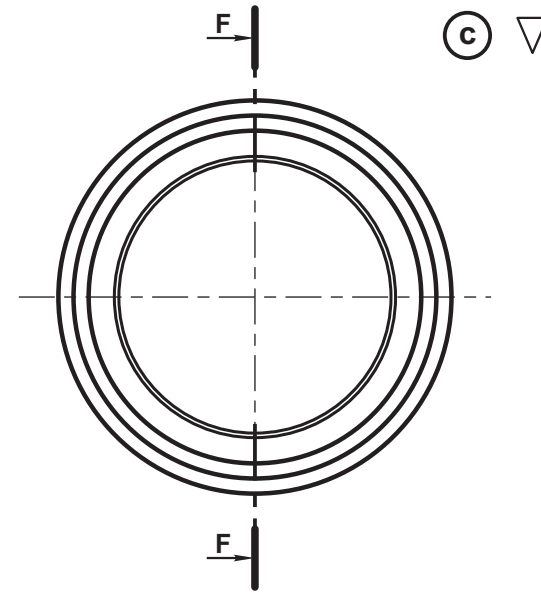
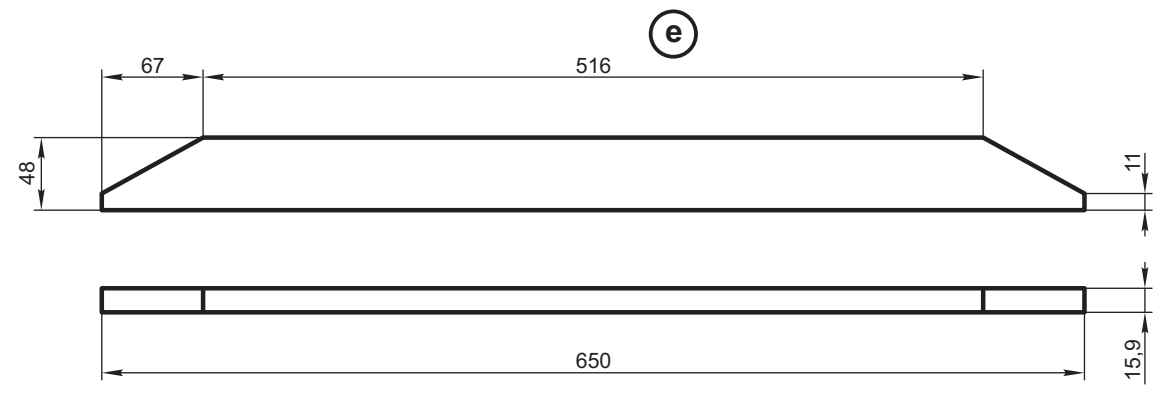
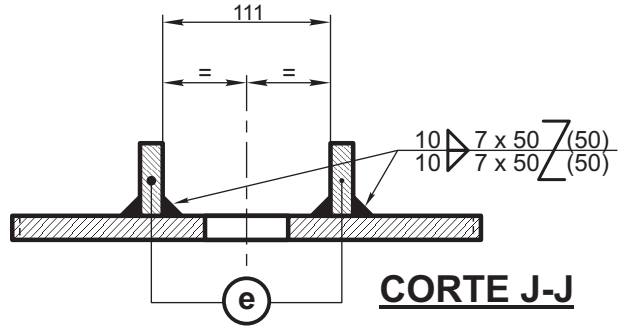
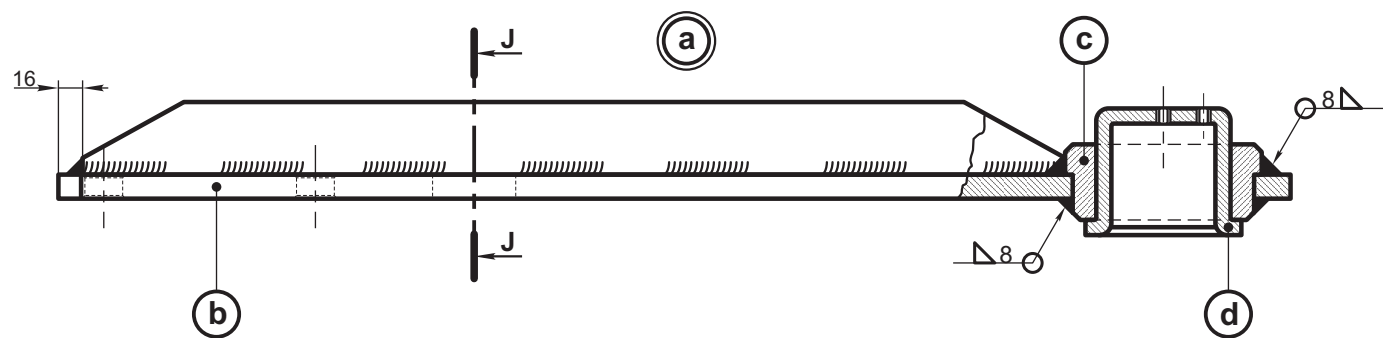

e	Refuerzo	2	Acero F.24 - IRAM-IAS U 500-503	
d		1	Ver NEFA 2-73-2-5014	9022722000/0
c	Buje	1	Acero 1020 - 1025 - IRAM 600	
b	Soporte	1	Acero F.24 - IRAM-IAS U 500-503	
a	Soporte para árbol de comando, completo			2/73/2/01/1901/0
ITEM	DESCRIPCION	Cant.	ESCUADRIA, ESPECIFICAC. Y OBSERVACIONES	CATAL-NOMEN.

SOPORTE
BASTIDOR: MANDO DEL FRENO DE VACIO

FERROCARRILES ARGENTINOS
AREA
MECANICA

ESCALA 1:2,5	TROCHA 1676	LINEAS: SAN MARTIN	UTILIZACION COCHES MATERFER	EMISION
-----------------	----------------	-----------------------	--------------------------------	---------

2	Se actualizó especificación del material de los ítems b y e - Ant. Acero F.24 - IRAM 503. Para ítem a va código, ant. 416 9022719000/0. Para ítem d cambiar descripción	13/12/84
EMISION	COTA	ALTERACIONES
		FECHA - FIRMA

FIRMA Y FECHA APROB.	Nº DE PLANO NEFA 2-73-2-5109	1	2
----------------------	--	---	---