

ANULA A MAT. 0579
Símbolos de soldadura IRAM 4536

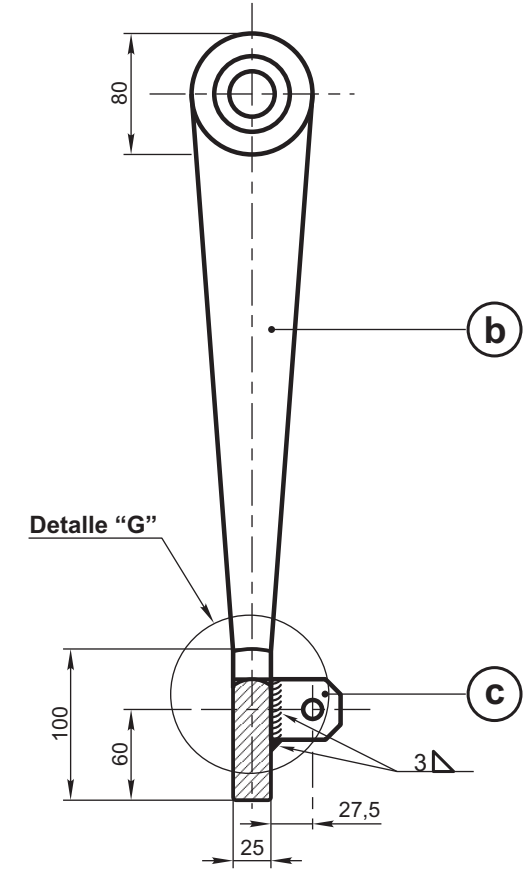

CORTE F-F

REF. FABRICA 2-58-215-443966

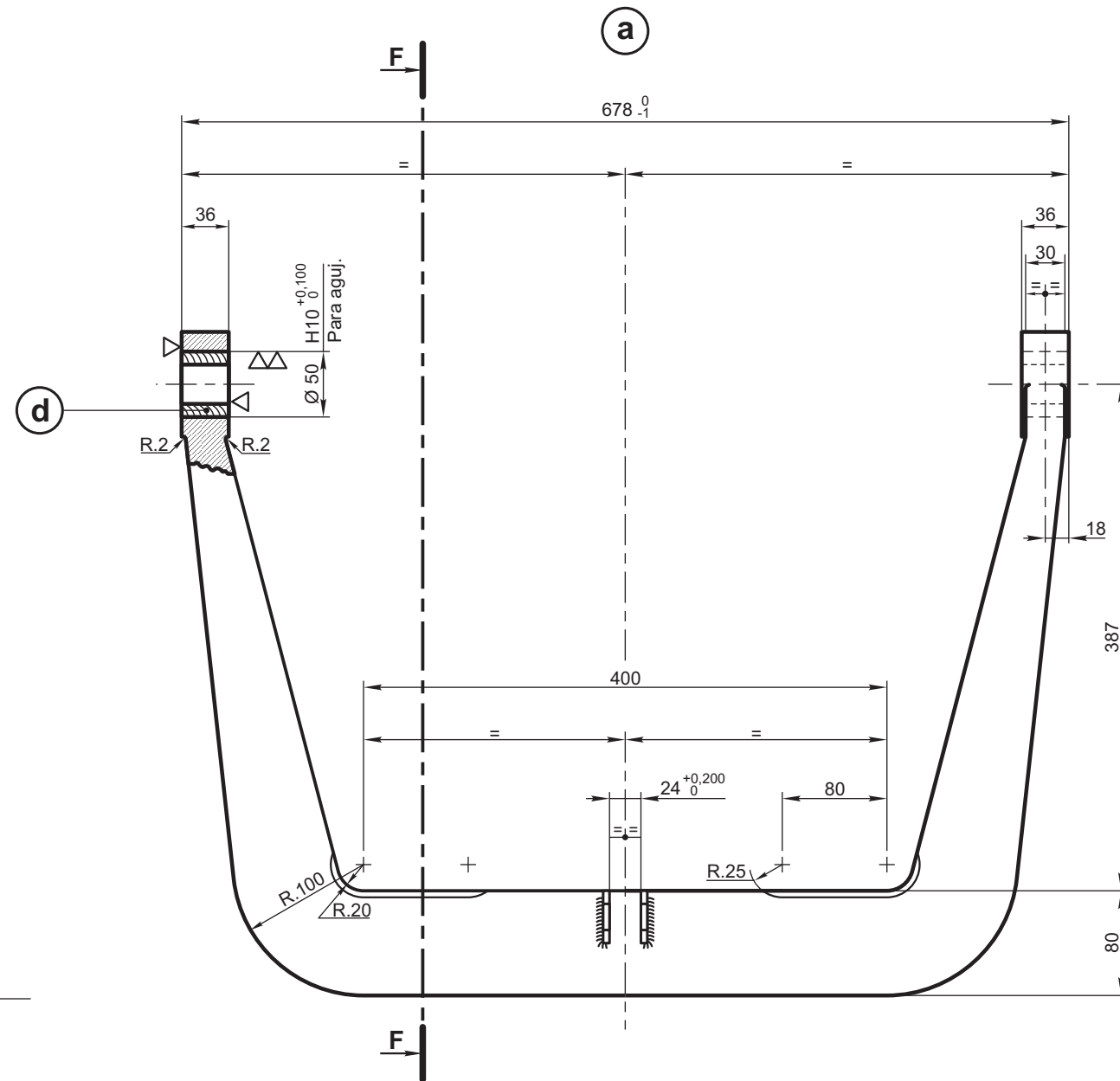
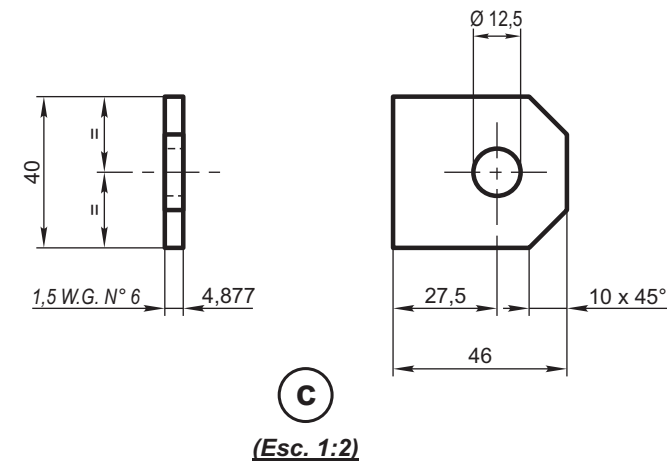
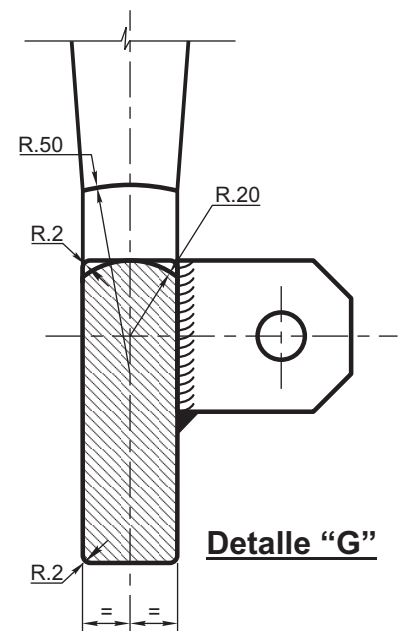

d	Buje	2	NEFA 2-73-1-5110	2/70/1/02/1805/0
c	Placa	2	Acero F-24 - IRAM-IAS U 500 503	
b	Brida solamente	1	Acero forjado A.42 - IRAM 538	2/70/1/02/1803/0
a	Brida completa			2/70/1/02/1800/0
ITEM	DESCRIPCION	Cant.	ESCUADRIA, ESPECIFICAC. Y OBSERVACIONES	CATAL-NOMEN.

BRIDA			FERROCARRILES ARGENTINOS	
BOGIES DE DOS EJES			AREA	
Suspension del bogie			MECANICA	

ESCALA 1:5	TROCHA 1676	LINEAS: SAN MARTIN	UTILIZACION COCHE MATERFER	EMISION			
FIRMA Y FECHA APROB.			N° DE PLANO NEFA 2-73-1-5080	<table border="1"> <tr> <td>1</td> <td>2</td> <td>3</td> </tr> </table>	1	2	3
1	2	3					

3	Para adaptar el dibujo al elem.compl. se agregó ítem "d" y se eliminó H.9022185 (ex) y se cambió Ref. anterior 2.58.216-44	12/12/90
2	Se actualizó IRAM 503	19/10/84
EMISION	COTA	ALTERACIONES
		FECHA - FIRMA