

PARA ACOTACIONES Y SIMBOLOS DE SOLDADURA
VER IRAM 4536

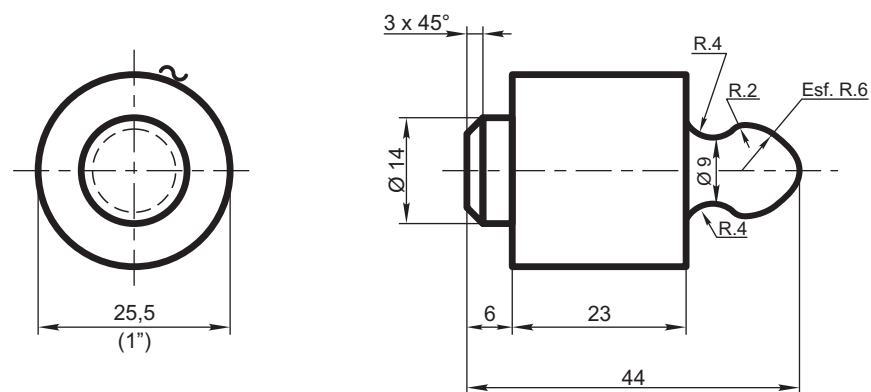
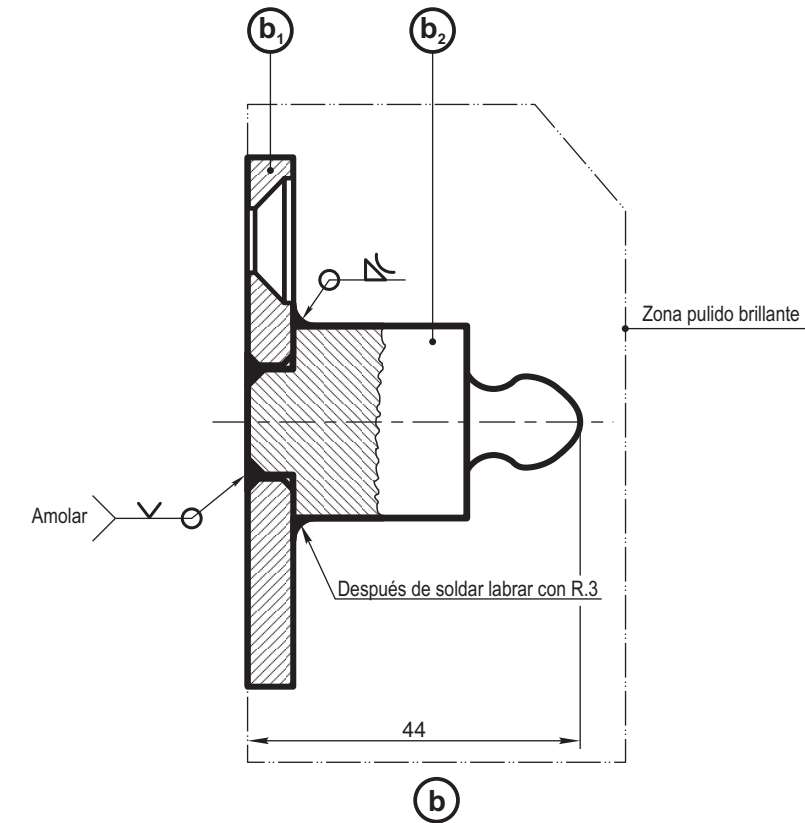
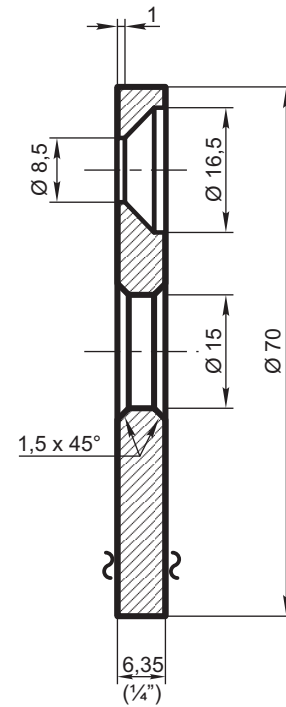
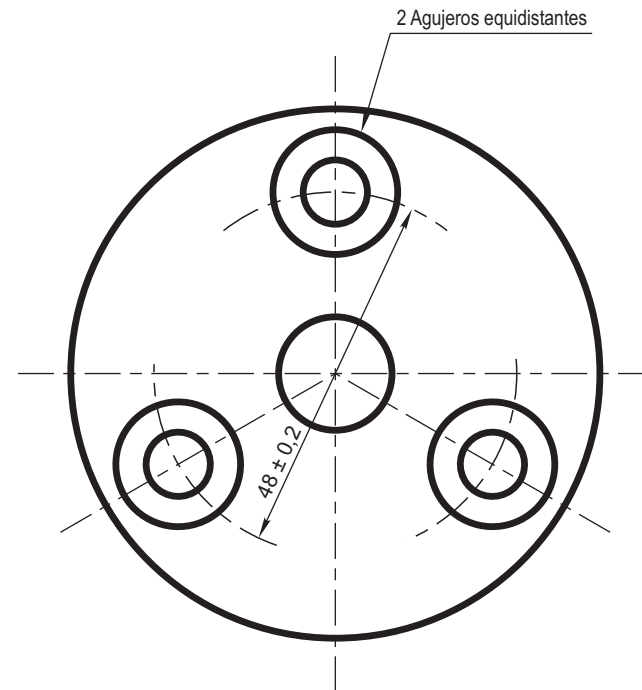

NOTA:

ES COMPONENTE DEL CONJUNTO COD. 2/70/2/27/4259/0 -
DIBUJO NEFA 2-70-2-5003

b ₂	Perno	1	Acero inoxidable designación 30304 IRAM 690 (AISI 304)	
b ₁	Disco	1		
b	Traba macho			2/70/2/27/4261/0
ITEM	DESCRIPCION	Cant.	ESCUADRIA, ESPECIFICAC. Y OBSERVACIONES	CATAL-NOMEN.

**TRABA
PUERTAS DE ACCESO**

**FERROCARRILES
ARGENTINOS**

AREA
MECANICA

ESCALA 1:1	TROCHA 1676	LINEAS: SAN MARTIN	UTILIZACION COCHES MATERFER	EMISION
---------------	----------------	-----------------------	--------------------------------	---------

2	Se colocó Código de acuerdo a carta GAP.IC 5/2 (2-70) P.M.150/87 del 22/1/87 y se cambió material, anterior F.20 IRAM 503	13/2/87
EMISION	COTA	ALTERACIONES
		FECHA - FIRMA

FIRMA Y FECHA APROB.	N° DE PLANO NEFA 2-70-2-5004	1	2
----------------------	--	---	---