

VISTA A -A'

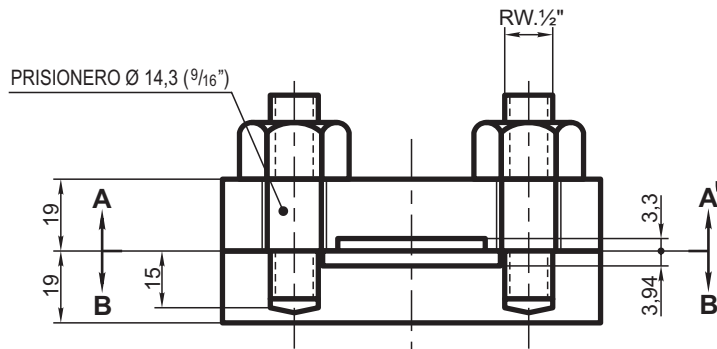

VISTA B -B'

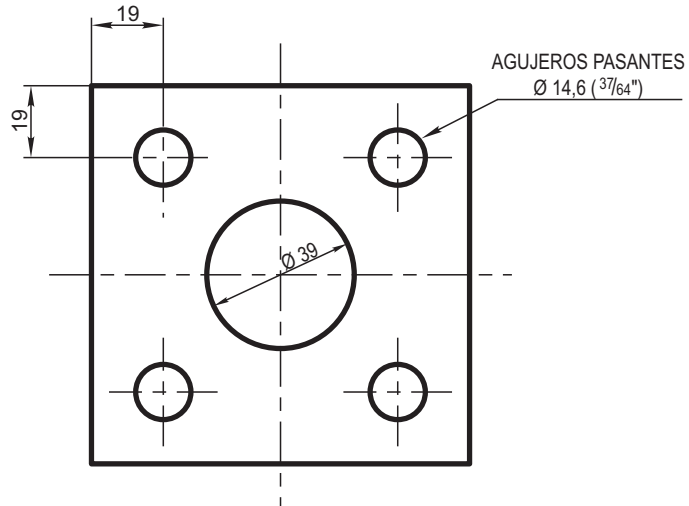
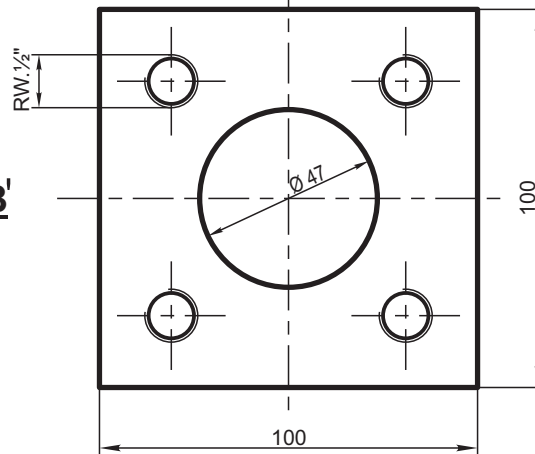

MATERIAL: ACERO IRAM 600 - CLASE 1020

ITEM	DESCRIPCION	CANT.	ESCUADRIA, ESPECIF. Y OBSERVAC.	CATAL-NOMEN.
DISPOSITIVO DE COMPRESION PARA JUNTA PARA ACOPLE DE MANGA				FERROCARRILES ARGENTINOS
				AREA MECANICA
ESCALA 1:2	TROCHA TODAS	LINEAS: TODAS	UTILIZACION MATERIAL RODANTE	EMISION
FIRMA Y FECHA APROB.		N° DE PLANO NEFA 370		1