

LABRADO NO ESPECIFICADO ▽▽ IRAM 4517	TOLERANCIAS SALVO ESPECIFICACION JS.15 = js.15 IRAM 5002
---	---

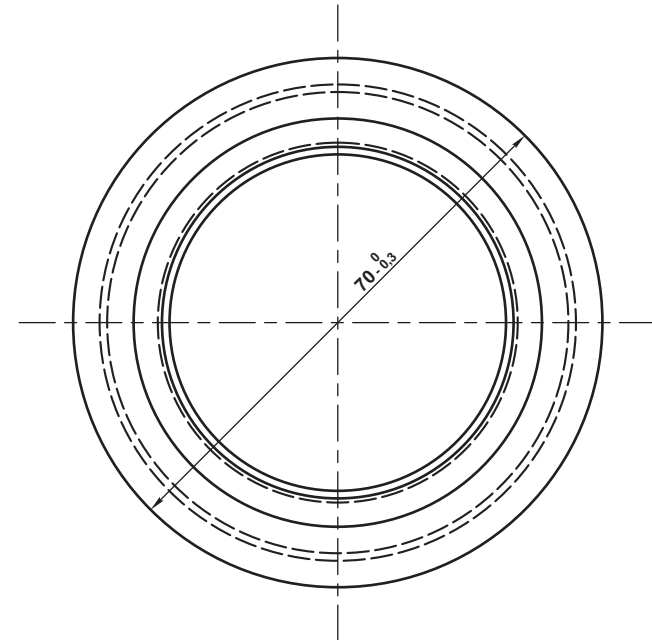
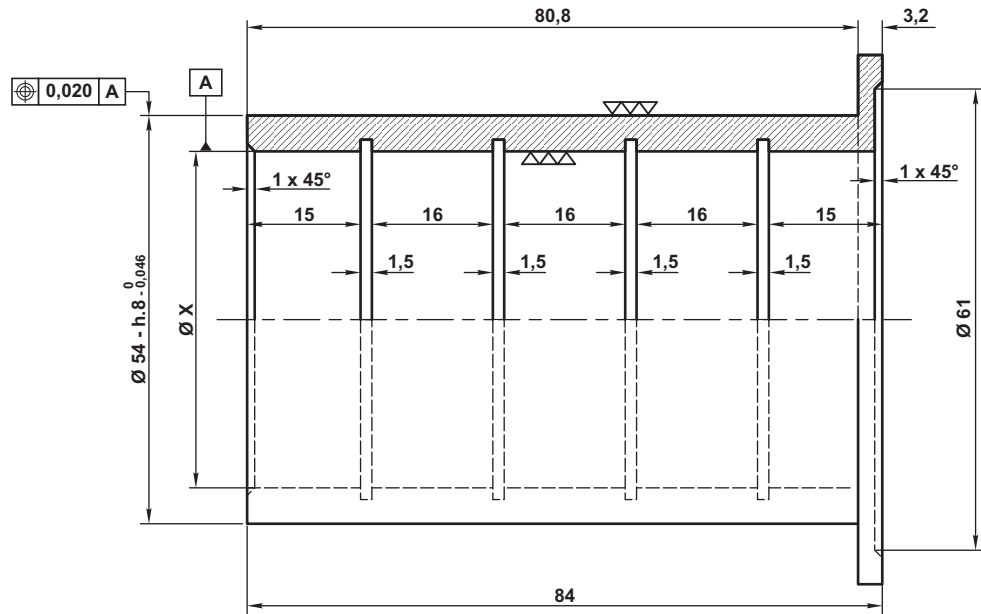

ELIMINAR REBABAS

ITEM	SIGNIFICADO	Ø X	N.U.M.
a	ORIGINAL	+ 0,064 44,5 F.8 +0,025	H.9050501000/0
b	1ra. SUBMEDIDA	+ 0,064 43,5 F.8 +0,025	

3		SE AGREGO SUB-MEDIDA	21/1/81
EMISION	COTA	ALTERACIONES	FECHA - FIRMA

b	BUJE 1° SUB-MEDIDA	BRONCE SAE 64	
a	BUJE ORIGINAL	BRONCE SAE 64	
ITEM	DESCRIPCION	CANT.	ESCUADRIA, ESPECIFICAC. Y OBSERVACIONES
BUJE PARA VASTAGO DE FRENO A VACIO DE Ø 609,6 (24")			FERROVIARIOS ARGENTINOS AREA MECANICA
ESCALA	TROCHA	LINEAS:	UTILIZACION
	1435 - 1676	SAN MARTIN - ROCA - SARMIENTO - MITRE - URQUIZA	COCHES
FIRMA Y FECHA APROB.	N° DE PLANO		EMISION
	NEFA 731		1 2 3

ES COPIA DEL PLANO NEFA 731
M. BELLOCHIO - AREA INGENIERIA - C.N.R.T.
E. 1:1