

TOLERANCIAS GENERALES

PIEZAS USINADAS	± 0,25 mm
PIEZAS FORJADAS	± 0,8 mm
PIEZAS EN CHAPAS	± 0,5 mm
ANGULOS	± 0,30°
MATAR CANTOS VIVOS	

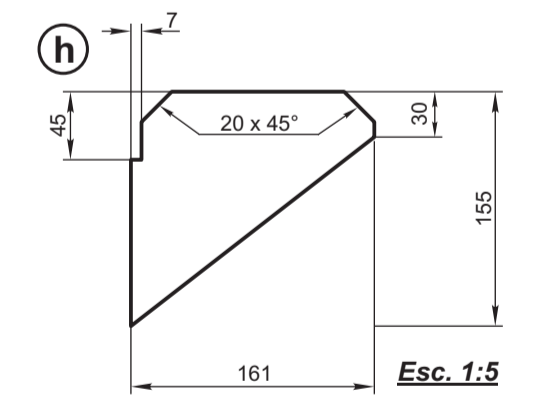

Cantidad {
2 Izquierdas
2 Centrales
2 Derechas

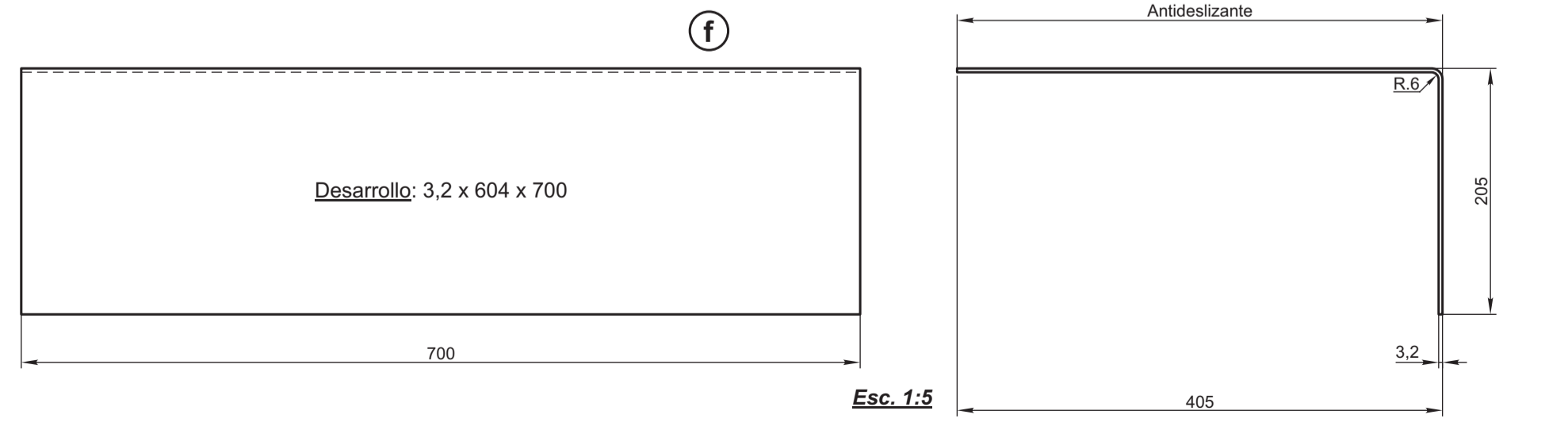
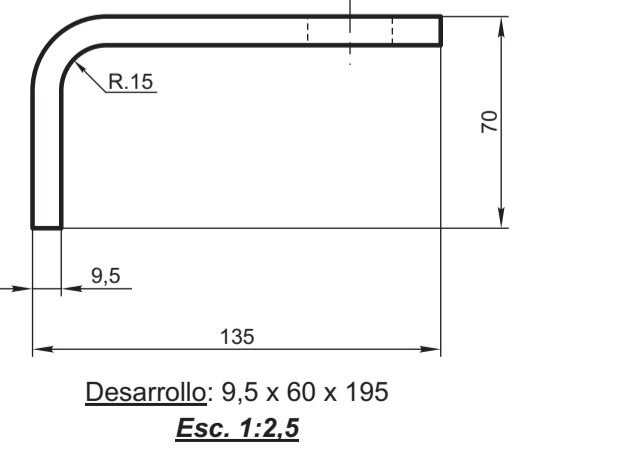
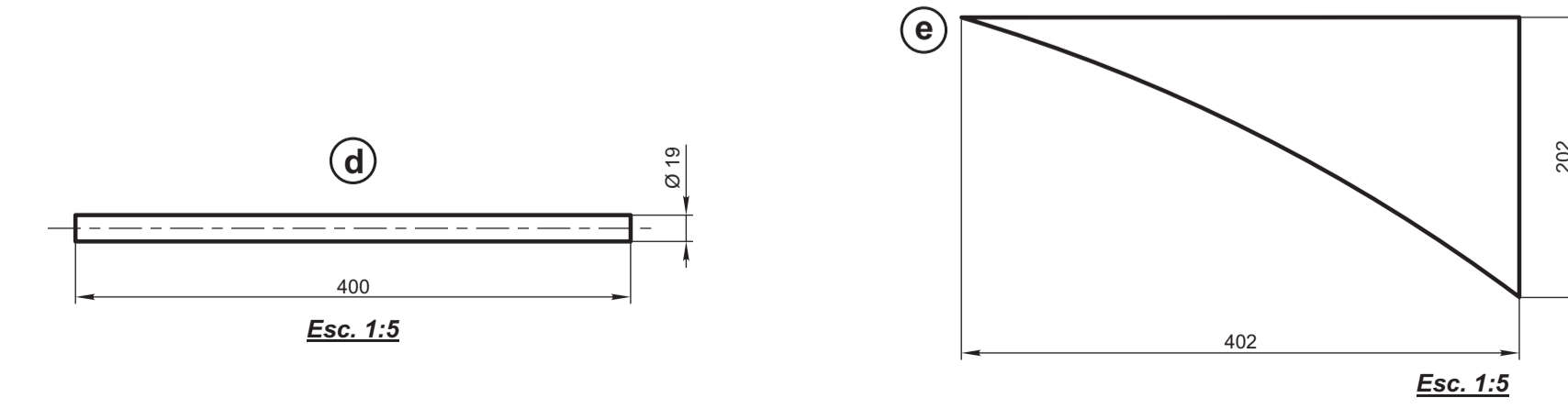
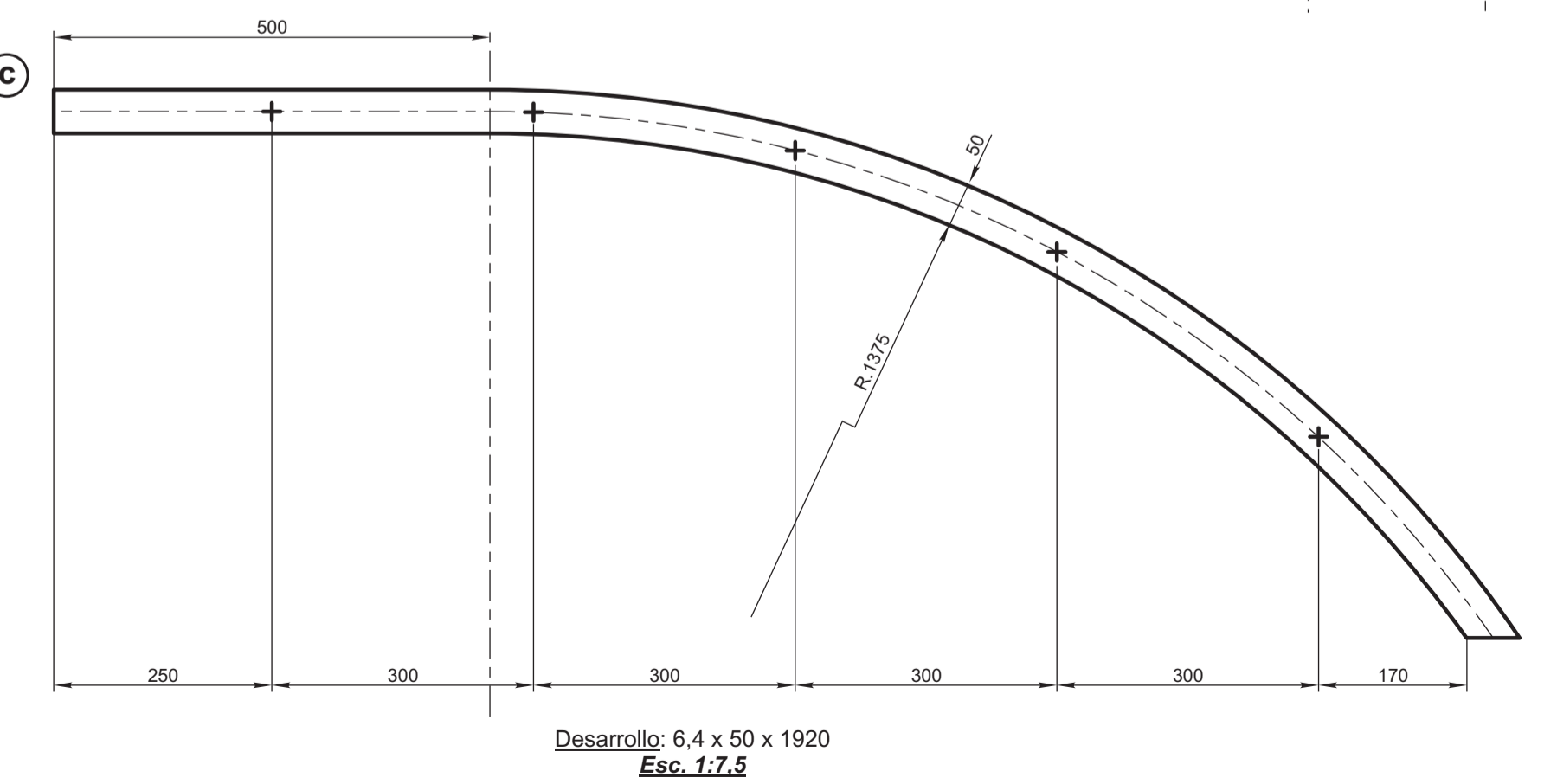
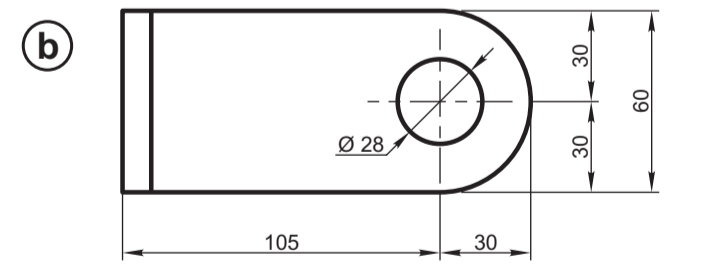
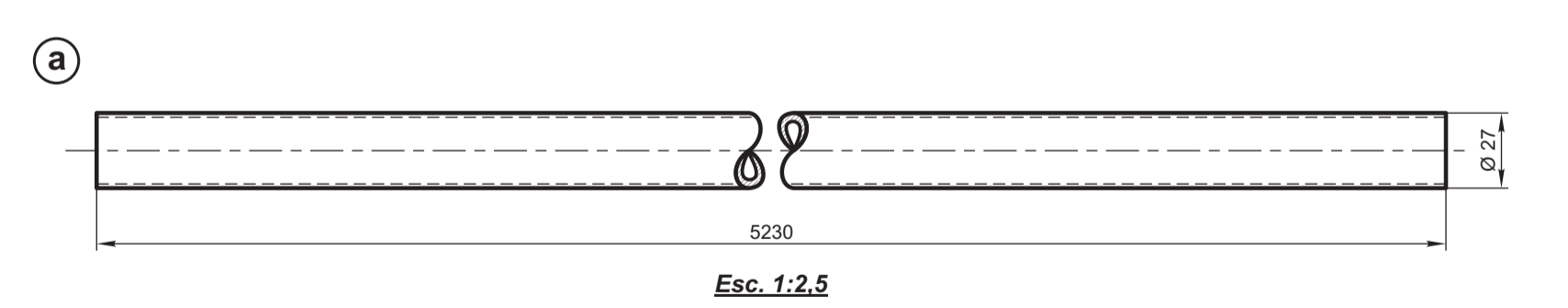

ITEM	DESCRIPCION	Cant x Coche	ESCUADRIA, ESPECIFICAC. Y OBSERVACIONES	CATAL-NOMEN.
i	Pasamanos central	2	Ø 19 Comercial	
h	Escuadras refuerzos	26	≠ 3,2 Comercial	
g	Pasareta long.	2	≠ 3,2 Comercial	
f	Plataforma superior	2	≠ 3,2 Comercial	
e	Escuadras refuerzos	4	≠ 3,2 Comercial	
d	Escalones	10	≠ 3,2 Comercial	
c	Lateral escalera	4	≠ 6,4 Comercial	
b	Soportes pasamanos	16	≠ 9,5 Comercial	
a	Pasamanos lateral	4	Ø e 26,9 Tubo para uso general	

VAGON TANQUE MONOCASCO		FERROVIARIOS ARGENTINOS
PLATAFORMAS, ESCALERAS Y PASAMANOS		
AREA		MECANICA

ESCALA 1:10	TROCHA 1000	LINEAS:	UTILIZACION	EMISION
FIRMA Y FECHA APROB.	N° DE PLANO NEFA 25.025			1