

Belgrano Cargas Y Logística

Provisión de equipos para automatización de pasos a nivel

Líneas San Marín y Belgrano

Esquemas funcionales PaN Juan Manuel de Rosas

REVISIONES			
n°	fecha	descripción	
A0	17/10/2019	CREACIÓN DEL DOCUMENTO	
DESCRIPCIÓN			TITULO
CARATULA DEL DOCUMENTO			ESQUEMAS FUNCIONALES PaN JM DE ROSAS
			CLIENTE
			BELGRANO CARGAS Y LOGISTICA
DIB	LC	FECHA	17/10/2019
REV	GM	FECHA DE EMISIÓN	17/10/2019
FECHA DE PLANO		PLOT TIME:	
17/10/2019			
LIB	RA	N° DE DOCUMENTO	(3)59053C-S0170-A0
		PROJ. NO.:	
		EST. NO.:	-
		HOJA	1 DE 20



Listado de contenidos en este documento

HOJA	DESCRIPCION
1	CARATULA DEL DOCUMENTO
2	LISTA DE CONTENIDOS
3	TRACK LAYOUT (ESQUEMÁTICO)
4	TOPOGRÁFICO RACK
5	ABRIGO - VISTA EN PLANTA
6	VISTA CARGADOR
7	CARGADORES Y BATERÍAS
8	FUENTE CDV C
9	SALIDA A CAMPO
10	CIRCUITOS DE VÍA
11	SSCC
12	PROTECCIONES S60
13	MECANISMO A
14	MECANISMO B
15	TELEALARMA
16	SEÑAL AL CONDUCTOR
17	LISTA DE COMPONENTES
18	LISTADO DE CABLES Y TIPO
19	LISTA DESDE HASTA
20	BORNERAS

REVISIONES			
n°	fecha	descripción	
A0	17/10/2019	CREACIÓN DEL DOCUMENTO	
DESCRIPCIÓN			TITULO
LISTA DE CONTENIDOS			ESQUEMAS FUNCIONALES PaN JM DE ROSAS
			CLIENTE
			BELGRANO CARGAS Y LOGISTICA
DIB	LC	FECHA	17/10/2019
REV	GM	FECHA DE EMISIÓN	17/10/2019
FECHA DE PLANO		17/10/2019	PLOT TIME:
LIB		RA	N° DE DOCUMENTO (3)59053C-S0170-A0
PROJ. NO.:		EST. NO.:	
HOJA		2	DE 20



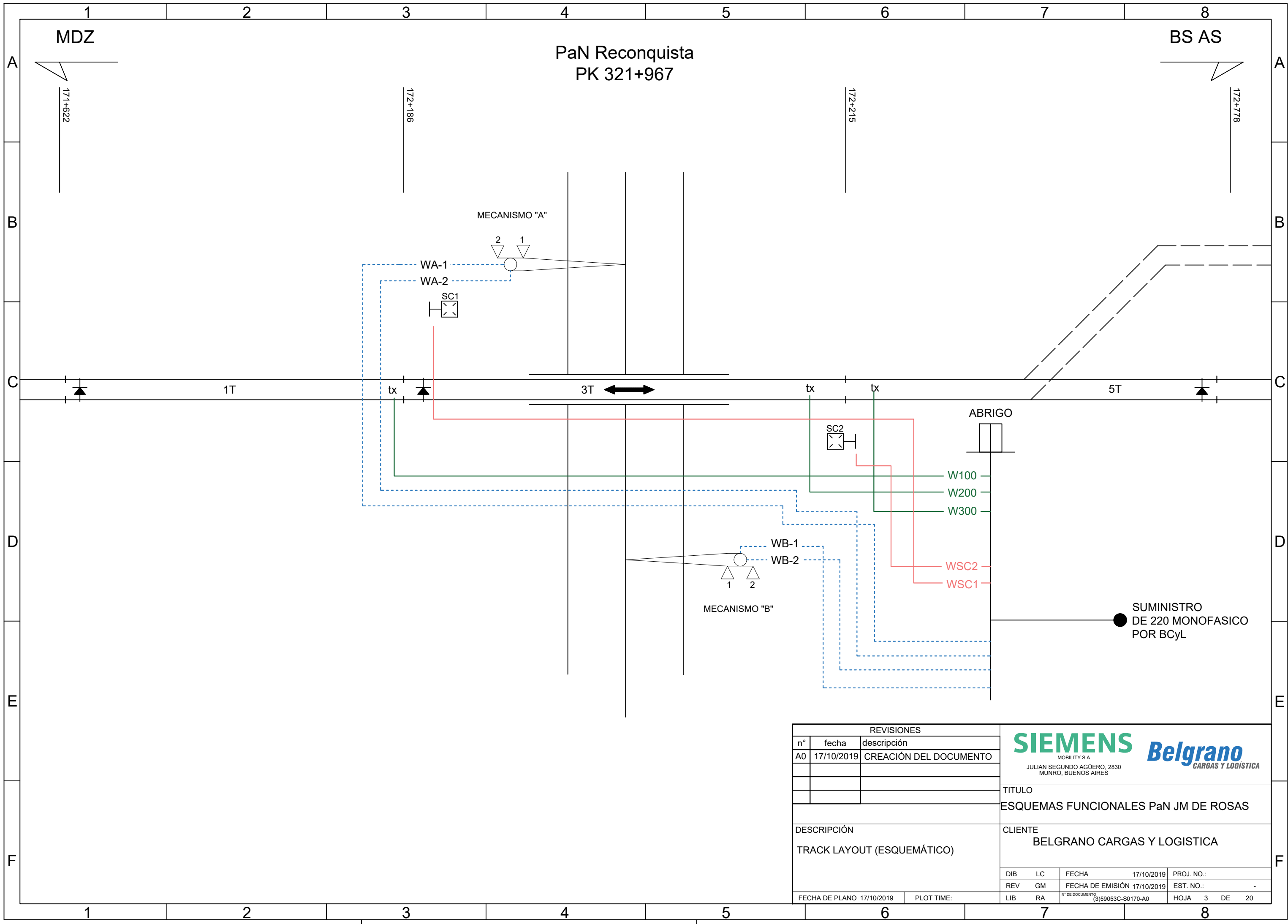

REVISIONES		
n°	fecha	descripción
A0	17/10/2019	CREACIÓN DEL DOCUMENTO
DESCRIPCIÓN		
TRACK LAYOUT (ESQUEMÁTICO)		
FECHA DE PLANO	17/10/2019	PLOT TIME:

SIEMENS *Belgrano*
MOBILITY S.A.
JULIAN SEGUNDO AGÜERO, 2830
MUNRO, BUENOS AIRES

TITULO
ESQUEMAS FUNCIONALES PaN JM DE ROSAS

CLIENTE
BELGRANO CARGAS Y LOGISTICA

DIB	LC	FECHA	17/10/2019	PROJ. NO.:	
REV	GM	FECHA DE EMISIÓN	17/10/2019	EST. NO.:	-
LIB	RA	N° DE DOCUMENTO	(3)59053C-S0170-A0	HOJA	3 DE 20

VISTA GENERAL DEL RACK

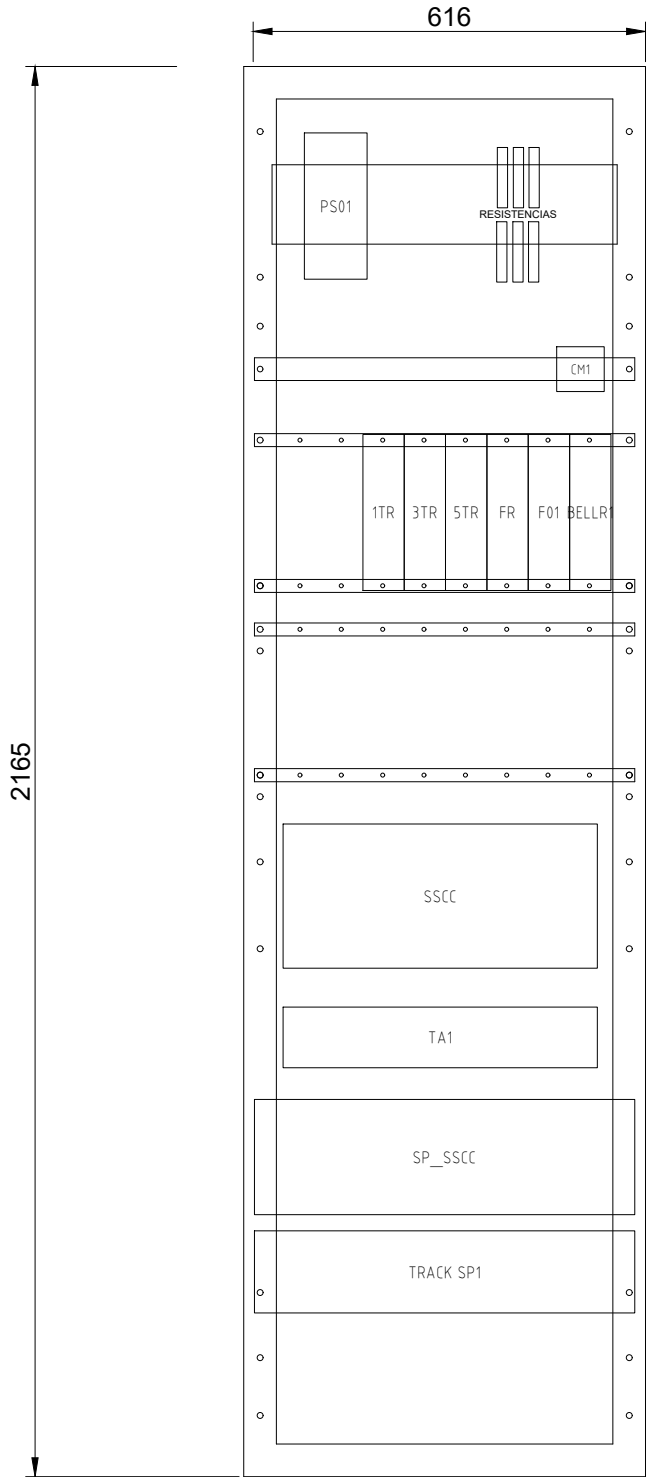

REVISIONES		
n°	fecha	descripción
A0	17/10/2019	CREACIÓN DEL DOCUMENTO
DESCRIPCIÓN		
TOPOGRÁFICO RACK		
FECHA DE PLANO	17/10/2019	PLOT TIME:

SIEMENS *Belgrano*
MOBILITY S.A.
 JULIAN SEGUNDO AGÜERO, 2830
 MUNRO, BUENOS AIRES
CARGAS Y LOGÍSTICA

TITULO
ESQUEMAS FUNCIONALES PaN JM DE ROSAS

CLIENTE
BELGRANO CARGAS Y LOGISTICA

DIB	LC	FECHA	17/10/2019	PROJ. NO.:	
REV	GM	FECHA DE EMISIÓN	17/10/2019	EST. NO.:	-
LIB	RA	N° DE DOCUMENTO	(3)59053C-S0170-A0	HOJA	4 DE 20

VISTA EN PLANTA DEL ABRIGO DE CONTROL

Tablero de distribución (*)

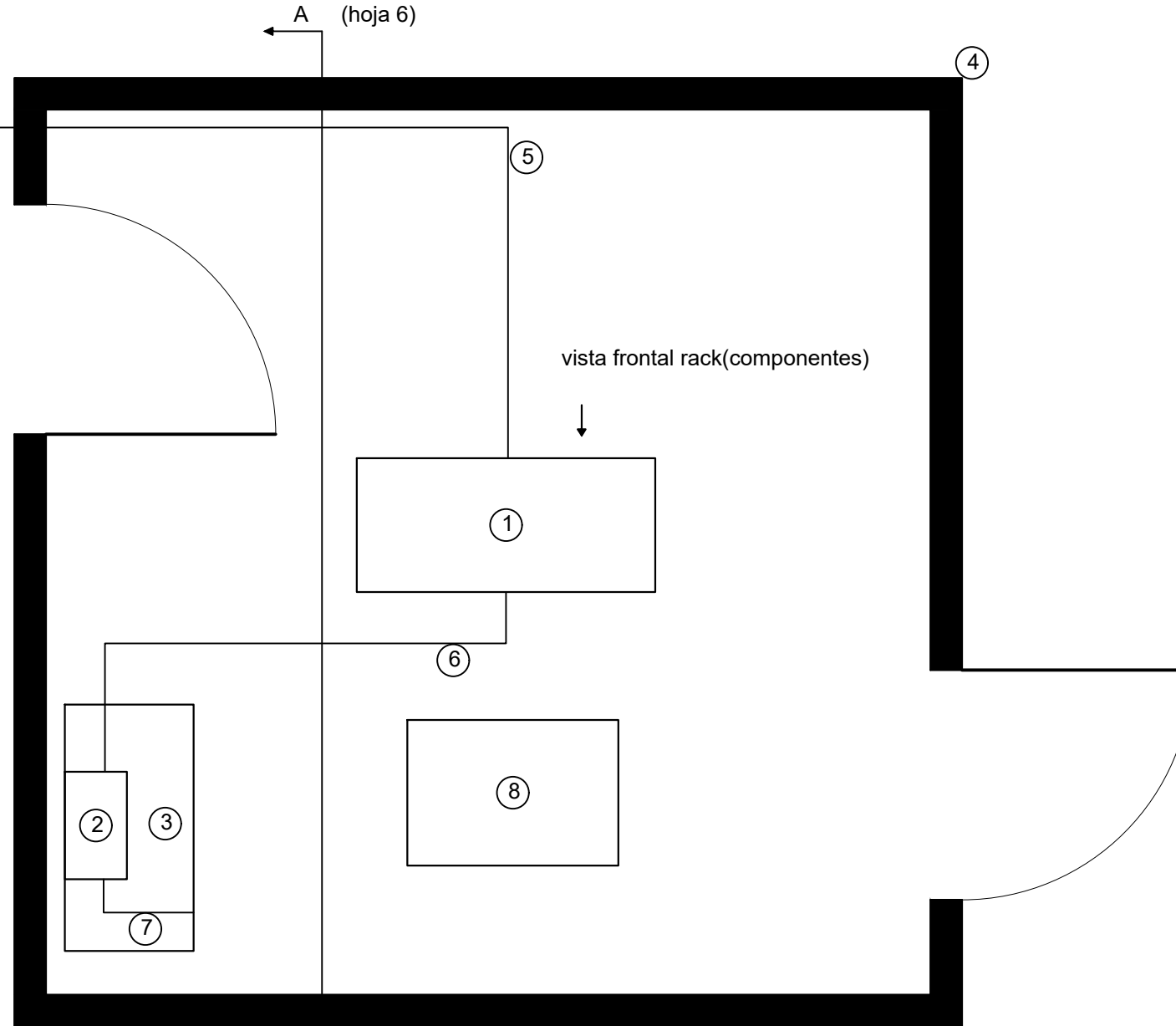
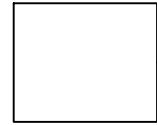

REFERENCIAS	
1	RACK DE CONTROL PaN
2	CARGADOR 12V
3	BANCO DE BATERÍAS 12V
4	TÍPICO DE ABRIGO - (3)59053C-C0004-A0
5	ALIMENTACIÓN PPAL
6	SALIDA DE CONSUMOS DEL CARGADOR 12 VDC
7	LÍNEA DE CARGA DE BATERÍAS
8	SALIDA DE CABLES A CAMPO

(*) el tablero de distribución general podrá estar dentro del abrigo

REVISIONES		
n°	fecha	descripción
A0	17/10/2019	CREACIÓN DEL DOCUMENTO

DESCRIPCIÓN	ABRIGO - VISTA EN PLANTA
FECHA DE PLANO	17/10/2019
PLOT TIME:	

<p>MOBILITY S.A JULIAN SEGUNDO AGÜERO, 2830 MUNRO, BUENOS AIRES</p>			
TITULO			
ESQUEMAS FUNCIONALES PaN JM DE ROSAS			
CLIENTE			
BELGRANO CARGAS Y LOGISTICA			
DIB	LC	FECHA	17/10/2019
REV	GM	FECHA DE EMISIÓN	17/10/2019
LIB	RA	N° DE DOCUMENTO	(3)59053C-S0170-A0
PROJ. NO.:		EST. NO.:	-
HOJA	5	DE	20

VISTA A-A - INSTALACIÓN EN PARED DEL CARTGADOR 12VDC

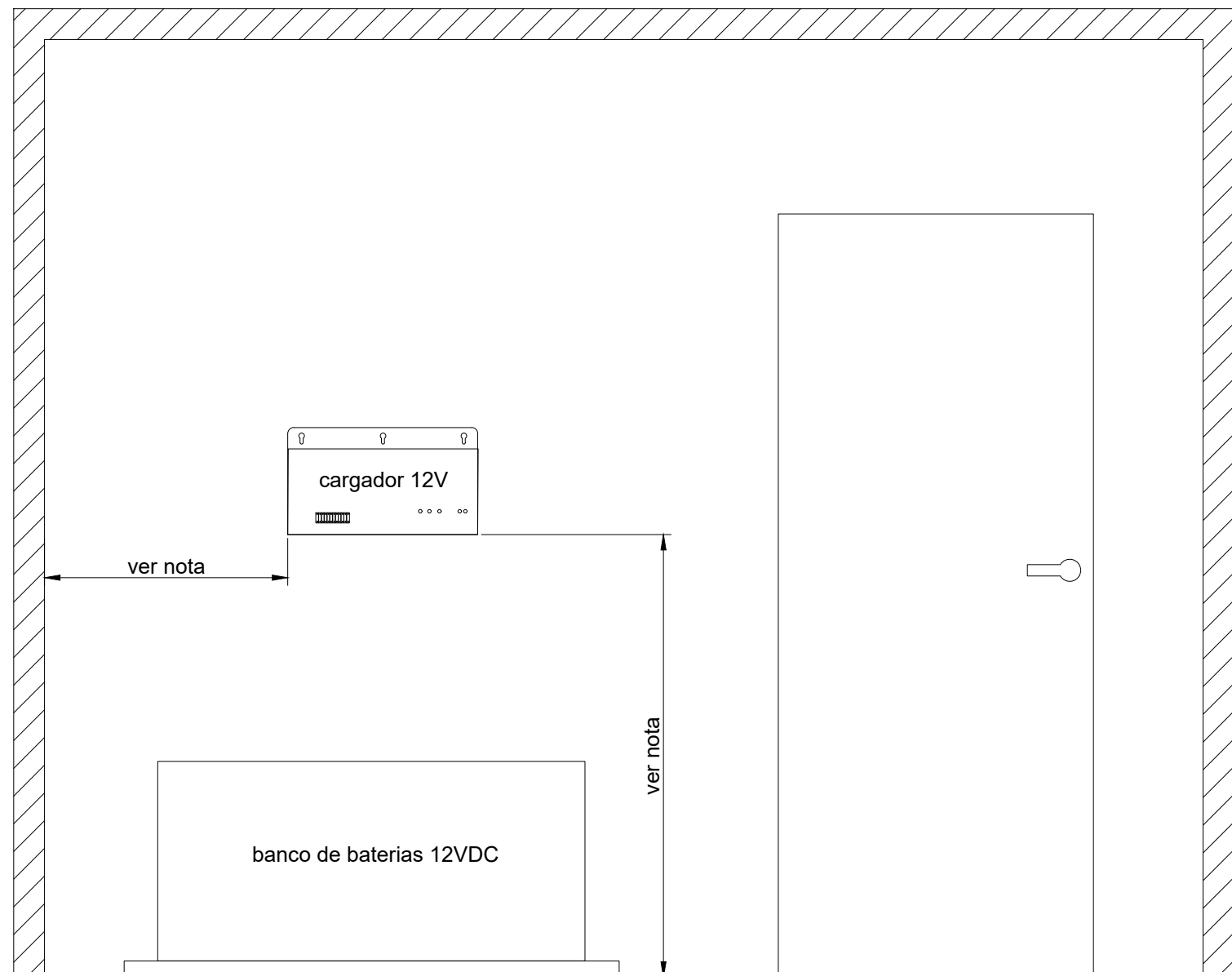

Nota: Las posiciones finales de los equipos de referencia serán determinadas en la próxima revisión.

Este plano es indicativo, no está a escala

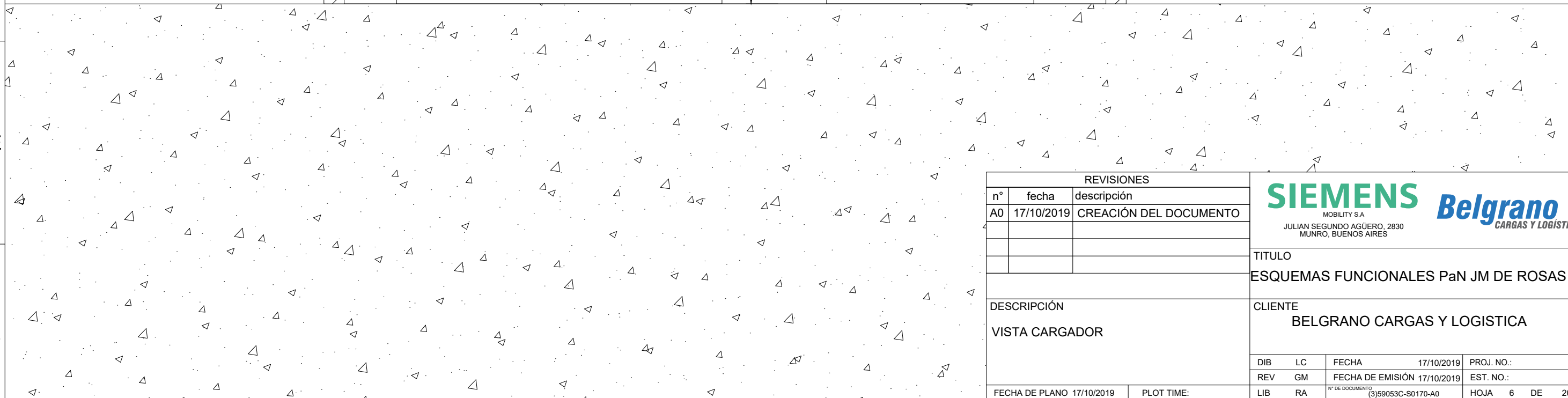

REVISIONES		
n°	fecha	descripción
A0	17/10/2019	CREACIÓN DEL DOCUMENTO
DESCRIPCIÓN		
VISTA CARGADOR		
FECHA DE PLANO	17/10/2019	PLOT TIME:

SIEMENS *Belgrano*
 MOBILITY S.A
 JULIAN SEGUNDO AGÜERO, 2830
 MUNRO, BUENOS AIRES

TITULO
 ESQUEMAS FUNCIONALES PaN JM DE ROSAS

CLIENTE
 BELGRANO CARGAS Y LOGISTICA

DIB	LC	FECHA	17/10/2019	PROJ. NO.:	
REV	GM	FECHA DE EMISIÓN	17/10/2019	EST. NO.:	-
LIB	RA	N° DE DOCUMENTO	(3)59053C-S0170-A0	HOJA	6 DE 20

220 AC
xxA

Suministro BCyL

Rack de contro PaN

ABRIGO-PARED

CB1
CARGADOR 12VDC

BAT

BT1
12 V / 150Ah

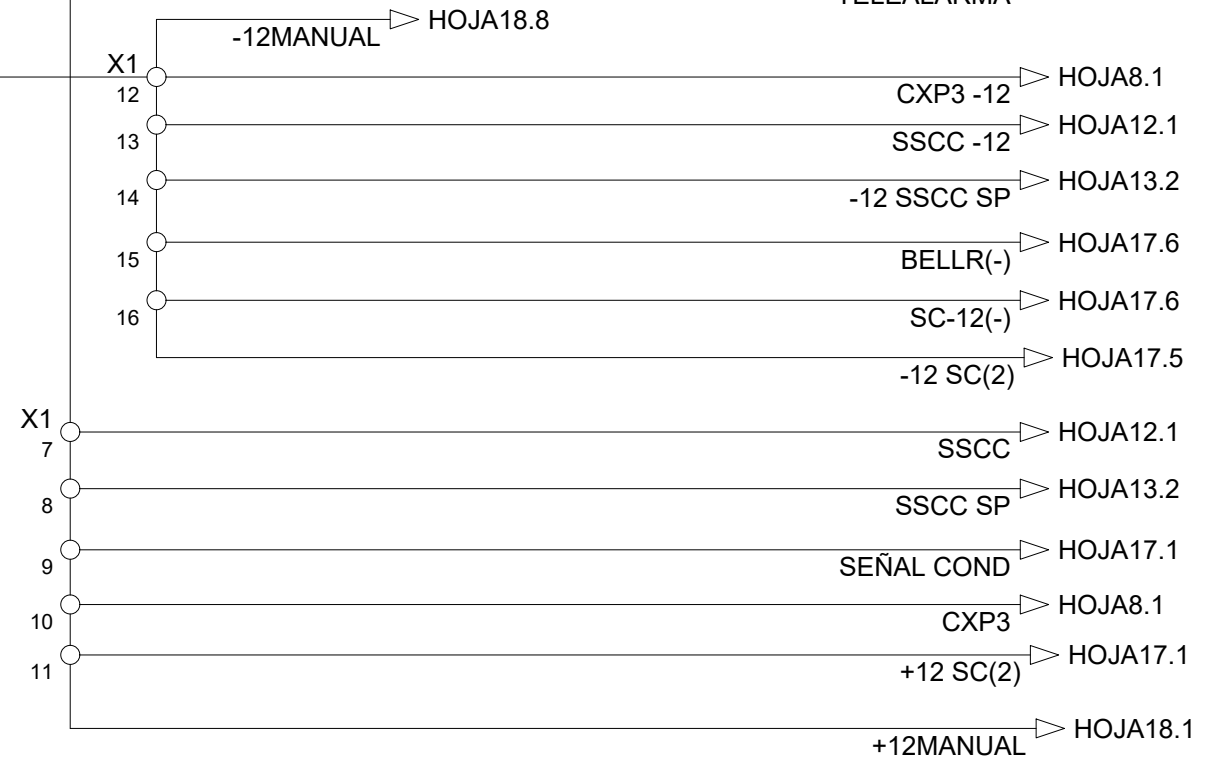
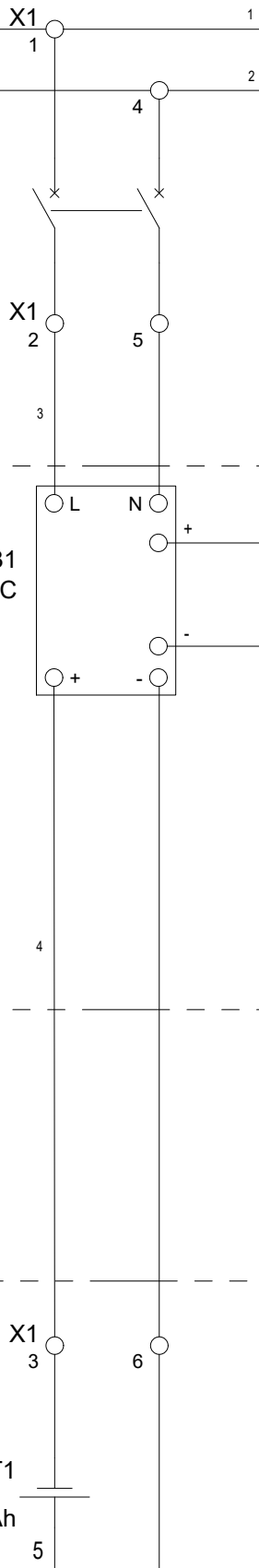

REVISIONES		
n°	fecha	descripción
A0	17/10/2019	CREACIÓN DEL DOCUMENTO
DESCRIPCIÓN		
CARGADORES Y BATERÍAS		
FECHA DE PLANO	17/10/2019	PLOT TIME:



TITULO			
ESQUEMAS FUNCIONALES PaN JM DE ROSAS			
CLIENTE			
BELGRANO CARGAS Y LOGISTICA			
DIB	LC	FECHA	17/10/2019
PROJ. NO.:			
REV	GM	FECHA DE EMISIÓN	17/10/2019
EST. NO.:			
LIB	RA	N° DE DOCUMENTO	(3)59053C-S0170-A0
HOJA	7	DE	20

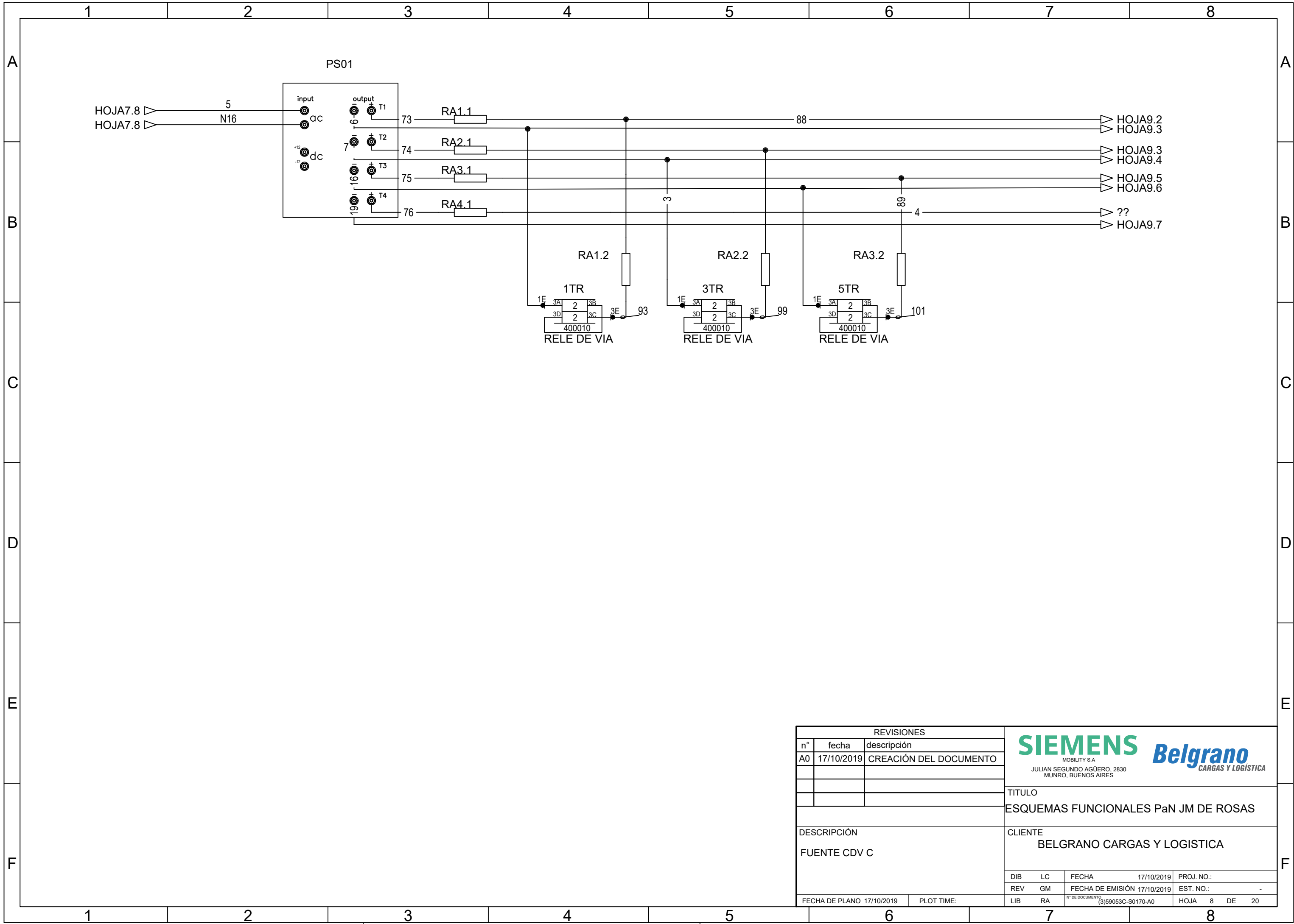

REVISIONES		
n°	fecha	descripción
A0	17/10/2019	CREACIÓN DEL DOCUMENTO
DESCRIPCIÓN		
FUENTE CDV C		
FECHA DE PLANO	17/10/2019	PLOT TIME:



TITULO			
ESQUEMAS FUNCIONALES PaN JM DE ROSAS			
CLIENTE			
BELGRANO CARGAS Y LOGISTICA			
DIB	LC	FECHA	17/10/2019
REV	GM	FECHA DE EMISIÓN	17/10/2019
LIB	RA	N° DE DOCUMENTO	(3)59053C-S0170-A0
PROJ. NO.:		EST. NO.:	-
HOJA	8	DE	20

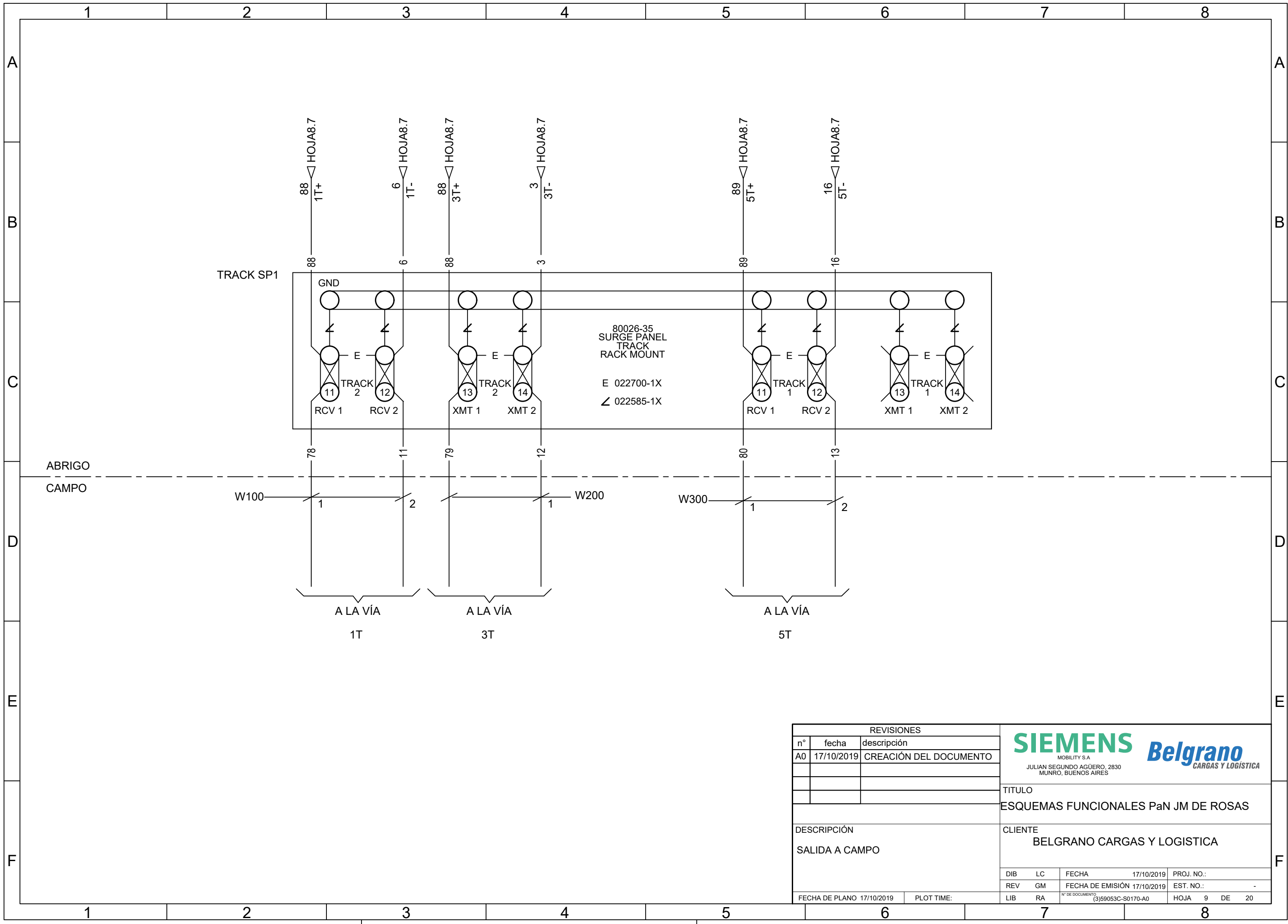

REVISIONES		
n°	fecha	descripción
A0	17/10/2019	CREACIÓN DEL DOCUMENTO
DESCRIPCIÓN		
SALIDA A CAMPO		
FECHA DE PLANO	17/10/2019	PLOT TIME:

SIEMENS *Belgrano*
MOBILITY S.A.
JULIAN SEGUNDO AGÜERO, 2830
MUNRO, BUENOS AIRES

TITULO
ESQUEMAS FUNCIONALES PaN JM DE ROSAS

CLIENTE
BELGRANO CARGAS Y LOGISTICA

DIB	LC	FECHA	17/10/2019	PROJ. NO.:	
REV	GM	FECHA DE EMISIÓN	17/10/2019	EST. NO.:	-
LIB	RA	N° DE DOCUMENTO	(3)59053C-S0170-A0	HOJA	9 DE 20

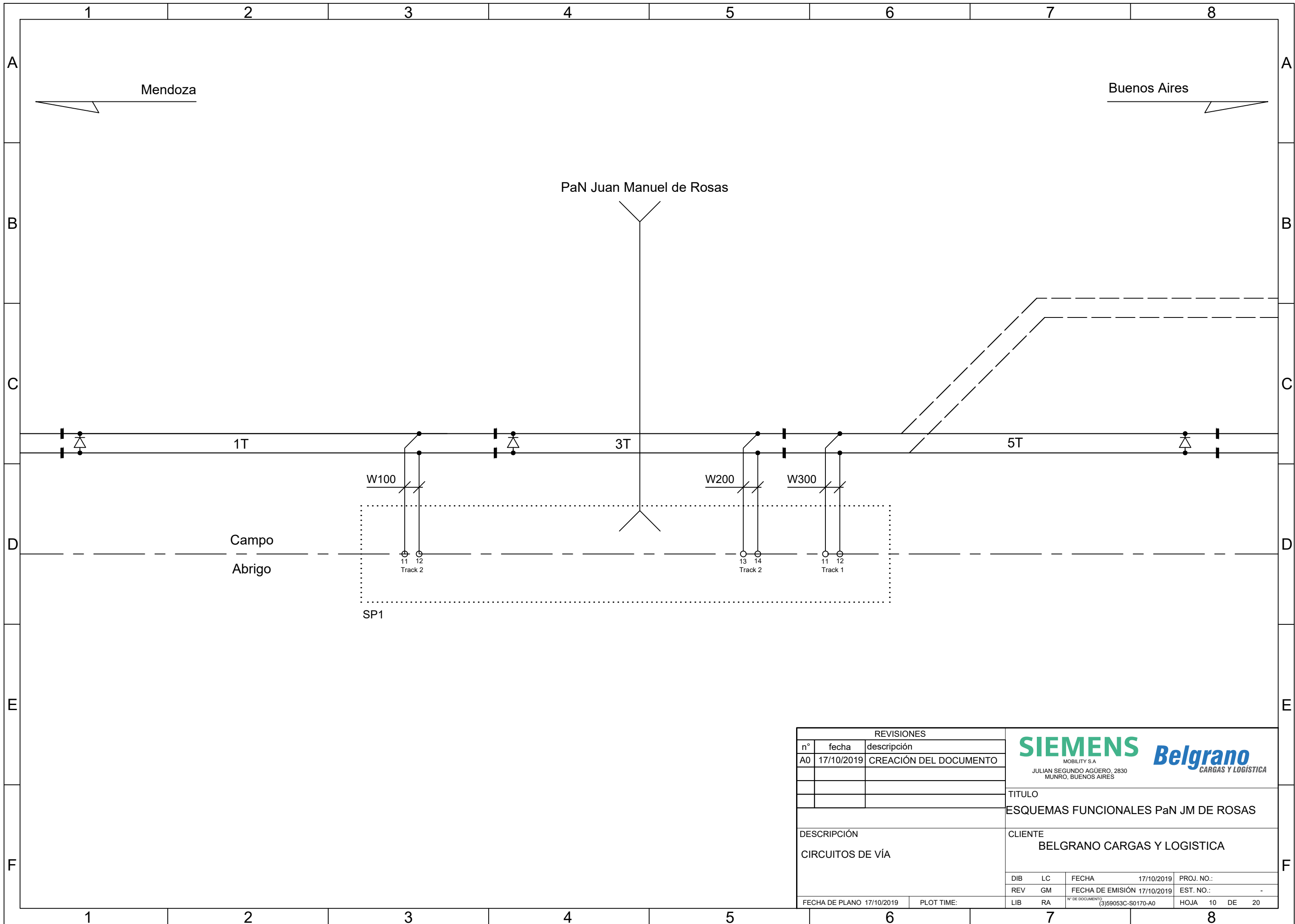

REVISIONES		
n°	fecha	descripción
A0	17/10/2019	CREACIÓN DEL DOCUMENTO
DESCRIPCIÓN		
CIRCUITOS DE VÍA		
FECHA DE PLANO	17/10/2019	PLOT TIME:



TITULO
ESQUEMAS FUNCIONALES PaN JM DE ROSAS

CLIENTE
BELGRANO CARGAS Y LOGISTICA

DIB	LC	FECHA	17/10/2019	PROJ. NO.:	
REV	GM	FECHA DE EMISIÓN	17/10/2019	EST. NO.:	-
LIB	RA	N° DE DOCUMENTO	(3)59053C-S0170-A0	HOJA	10 DE 20

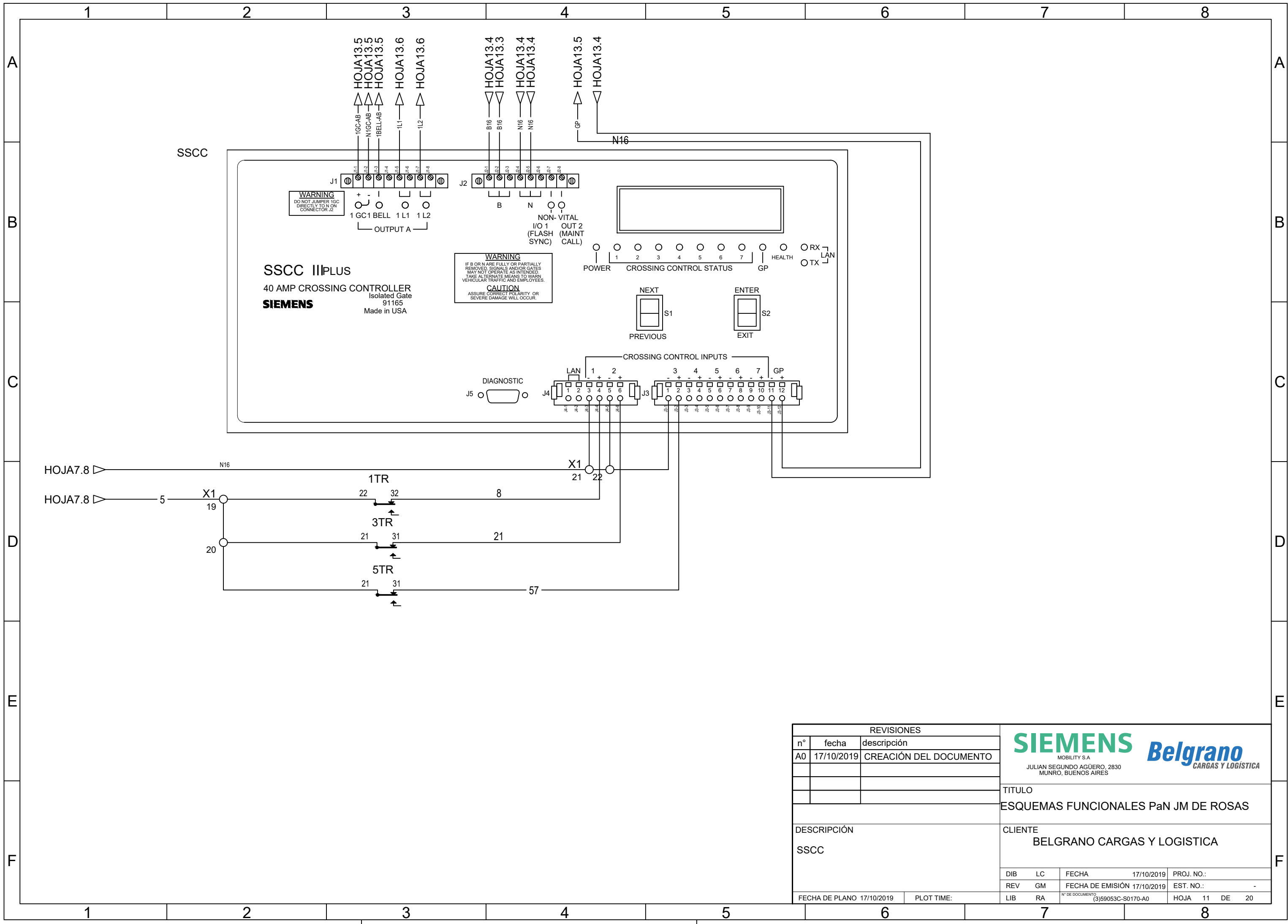

WARNING
DO NOT JUMPER 1GC DIRECTLY TO N ON CONNECTOR J2

WARNING
IF B OR N ARE FULLY OR PARTIALLY REMOVED, SIGNALS AND/OR GATES MAY NOT OPERATE AS INTENDED. TAKE ALTERNATE MEANS TO WARN VEHICULAR TRAFFIC AND EMPLOYEES.

CAUTION
ASSURE CORRECT POLARITY OR SEVERE DAMAGE WILL OCCUR.

SSCC IIPLUS
40 AMP CROSSING CONTROLLER
Isolated Gate
91165
SIEMENS
Made in USA

REVISIONES		
n°	fecha	descripción
A0	17/10/2019	CREACIÓN DEL DOCUMENTO

SIEMENS *Belgrano*
MOBILITY S.A.
JULIAN SEGUNDO AGÜERO, 2830
MUNRO, BUENOS AIRES

TITULO
ESQUEMAS FUNCIONALES PaN JM DE ROSAS

CLIENTE
BELGRANO CARGAS Y LOGISTICA

DIB	LC	FECHA	17/10/2019	PROJ. NO.:	
REV	GM	FECHA DE EMISIÓN	17/10/2019	EST. NO.:	-
LIB	RA	N° DE DOCUMENTO	(3)59053C-S0170-A0	HOJA	11 DE 20

FECHA DE PLANO 17/10/2019 PLOT TIME:

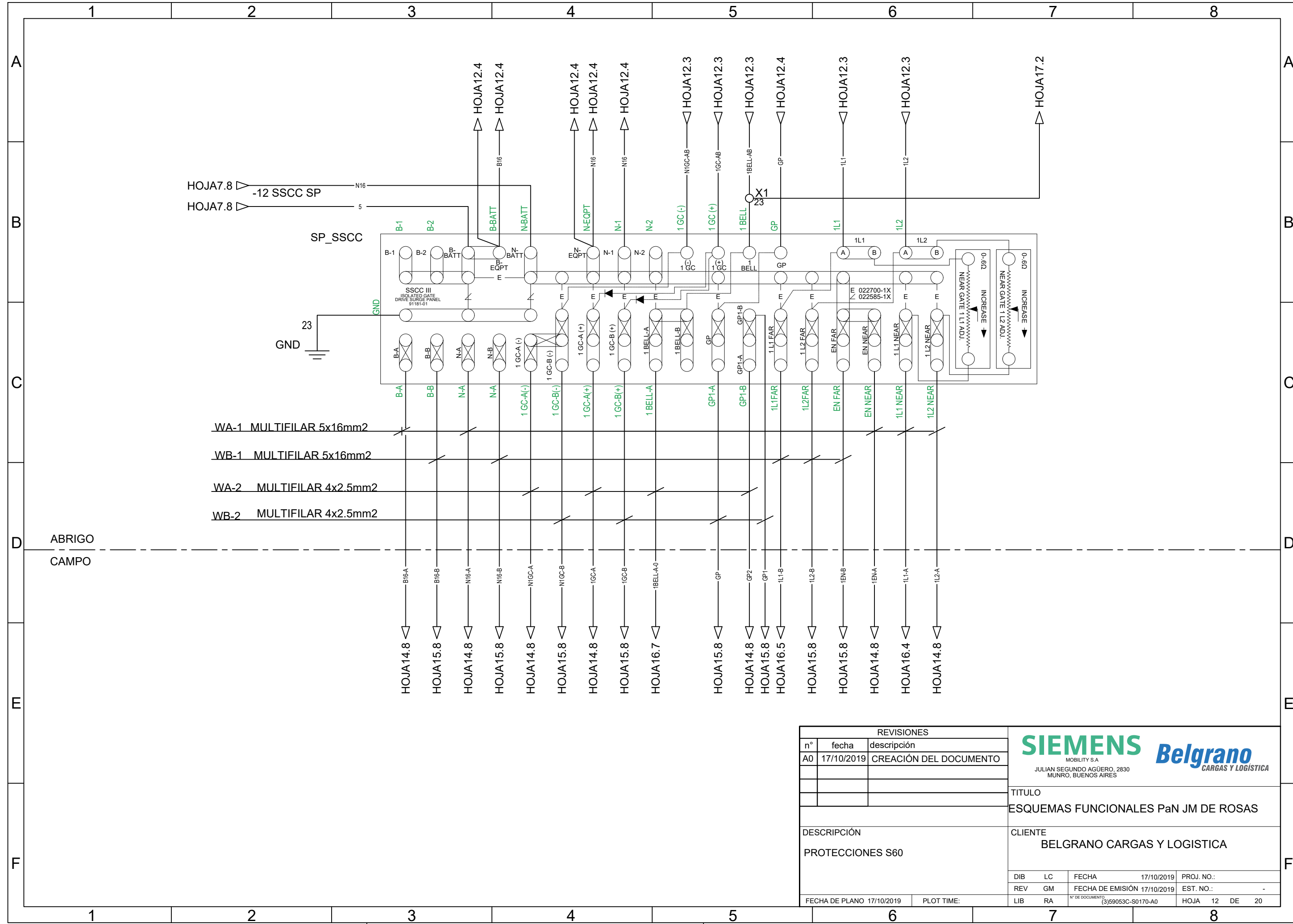

HOJA7.8 -12 SSCC SP
 HOJA7.8 5

SP_SSCC

GND 23

WA-1 MULTIFILAR 5x16mm2
 WB-1 MULTIFILAR 5x16mm2
 WA-2 MULTIFILAR 4x2.5mm2
 WB-2 MULTIFILAR 4x2.5mm2

ABRIGO
 CAMPO

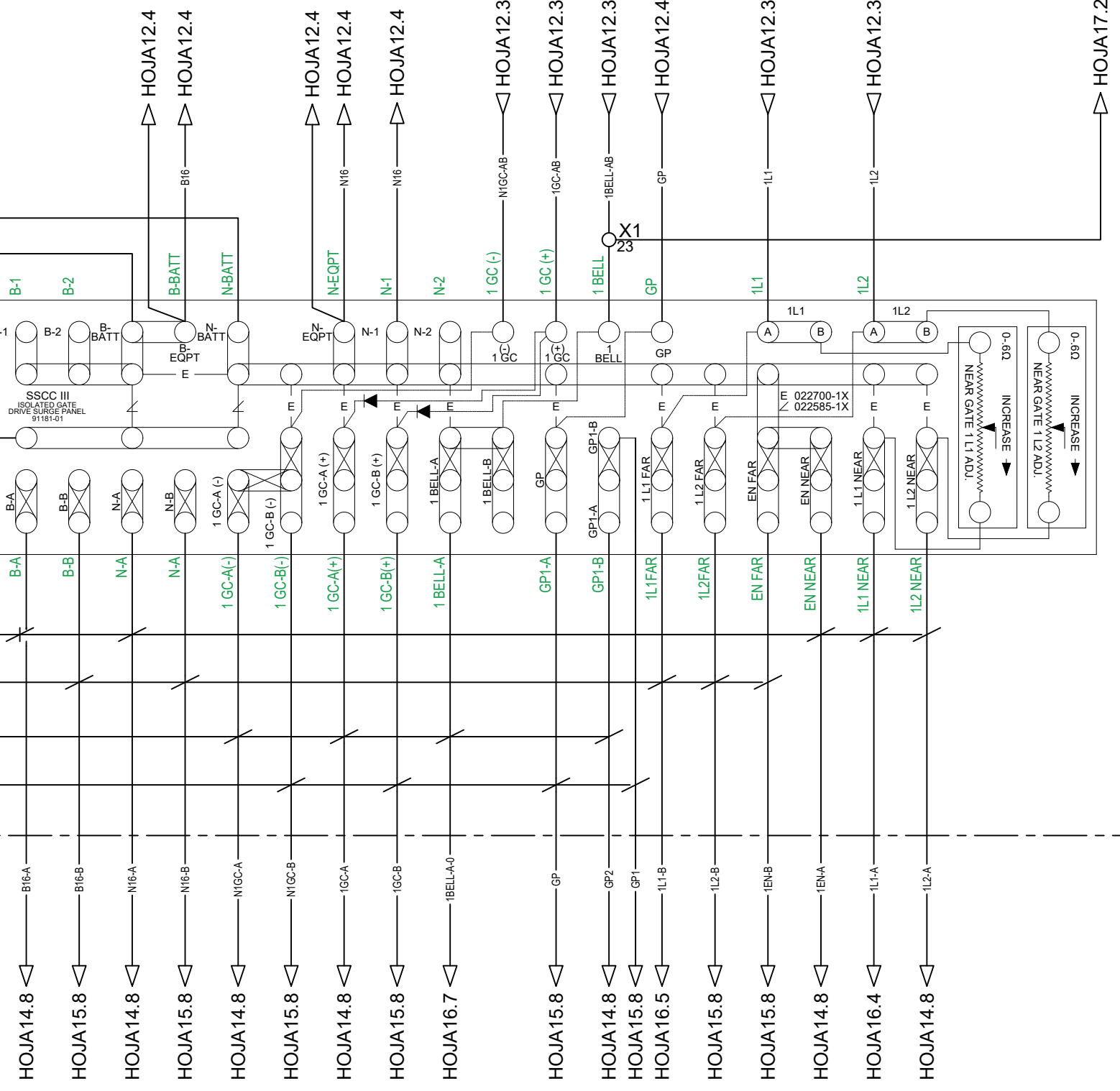

REVISIONES		
n°	fecha	descripción
A0	17/10/2019	CREACIÓN DEL DOCUMENTO
DESCRIPCIÓN		
PROTECCIONES S60		
FECHA DE PLANO	17/10/2019	PLOT TIME:



TITULO			
ESQUEMAS FUNCIONALES PaN JM DE ROSAS			
CLIENTE			
BELGRANO CARGAS Y LOGISTICA			
DIB	LC	FECHA	17/10/2019
REV	GM	FECHA DE EMISIÓN	17/10/2019
LIB	RA	N° DE DOCUMENTO	(3)59053C-S0170-A0
PROJ. NO.:		EST. NO.:	-
HOJA	12	DE	20

1 2 3 4 5 6 7 8

A
B
C
D
E
F

ACCIONAMIENTO DE BARRERA "S60"		
CONTACTO	CONTACTO CERRADO EN	FUNCIÓN DEL CONTACTO
6	70°-90°	CONTROL DE ENERGIA(BAJAR)
7	0°-89°	CONTROL DE ENERGIA(SUBIR)
8	83°-90°	CONTROL DEL DESTELLADOR
9	5°-90°	CONTROL DE CAMPANA
10	0°-5°	INDICACIÓN DE BRAZO BAJO
11		RESERVA
12		RESERVA

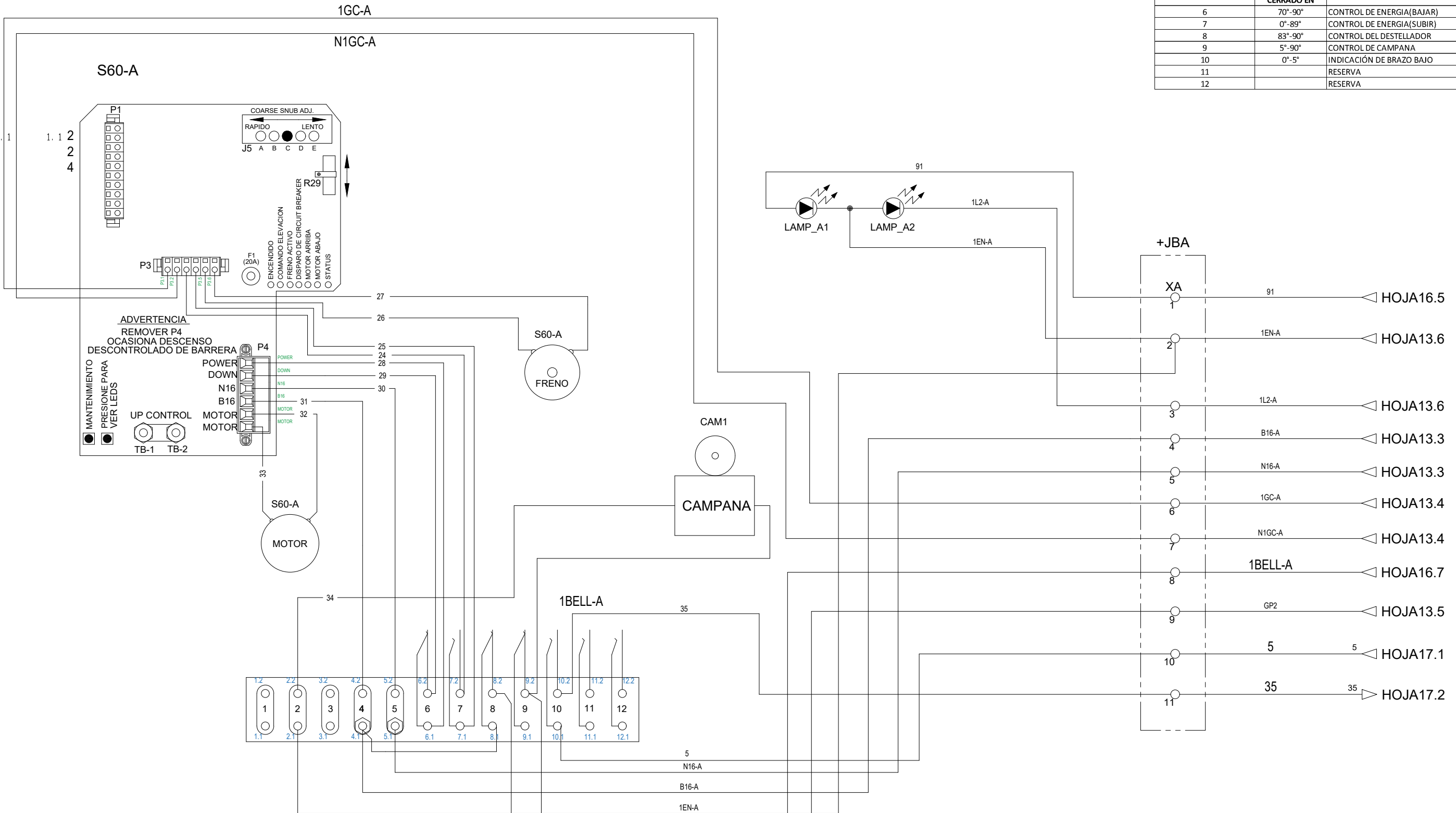

REVISIONES		
n°	fecha	descripción
A0	17/10/2019	CREACIÓN DEL DOCUMENTO

FECHA DE PLANO 17/10/2019 PLOT TIME:

SIEMENS Belgrano
MOBILITY S.A
JULIAN SEGUNDO AGÜERO, 2830
MUNRO, BUENOS AIRES

TITULO
ESQUEMAS FUNCIONALES PaN JM DE ROSAS

CLIENTE
BELGRANO CARGAS Y LOGISTICA

DIB	LC	FECHA	17/10/2019	PROJ. NO.:	
REV	GM	FECHA DE EMISIÓN	17/10/2019	EST. NO.:	-
LIB	RA	N° DE DOCUMENTO	(3)59053C-S0170-A0	HOJA	13 DE 20

1 2 3 4 5 6 7 8

ACCIONAMIENTO DE BARRERA "S60"		
CONTACTO	CONTACTO CERRADO EN	FUNCIÓN DEL CONTACTO
6	70°-90°	CONTROL DE ENERGIA(BAJAR)
7	0°-89°	CONTROL DE ENERGIA(SUBIR)
8	83°-90°	CONTROL DEL DESTELLADOR
9	5°-90°	CONTROL DE CAMPANA
10	0°-5°	INDICACIÓN DE BRAZO BAJO
11		RESERVA
12		RESERVA

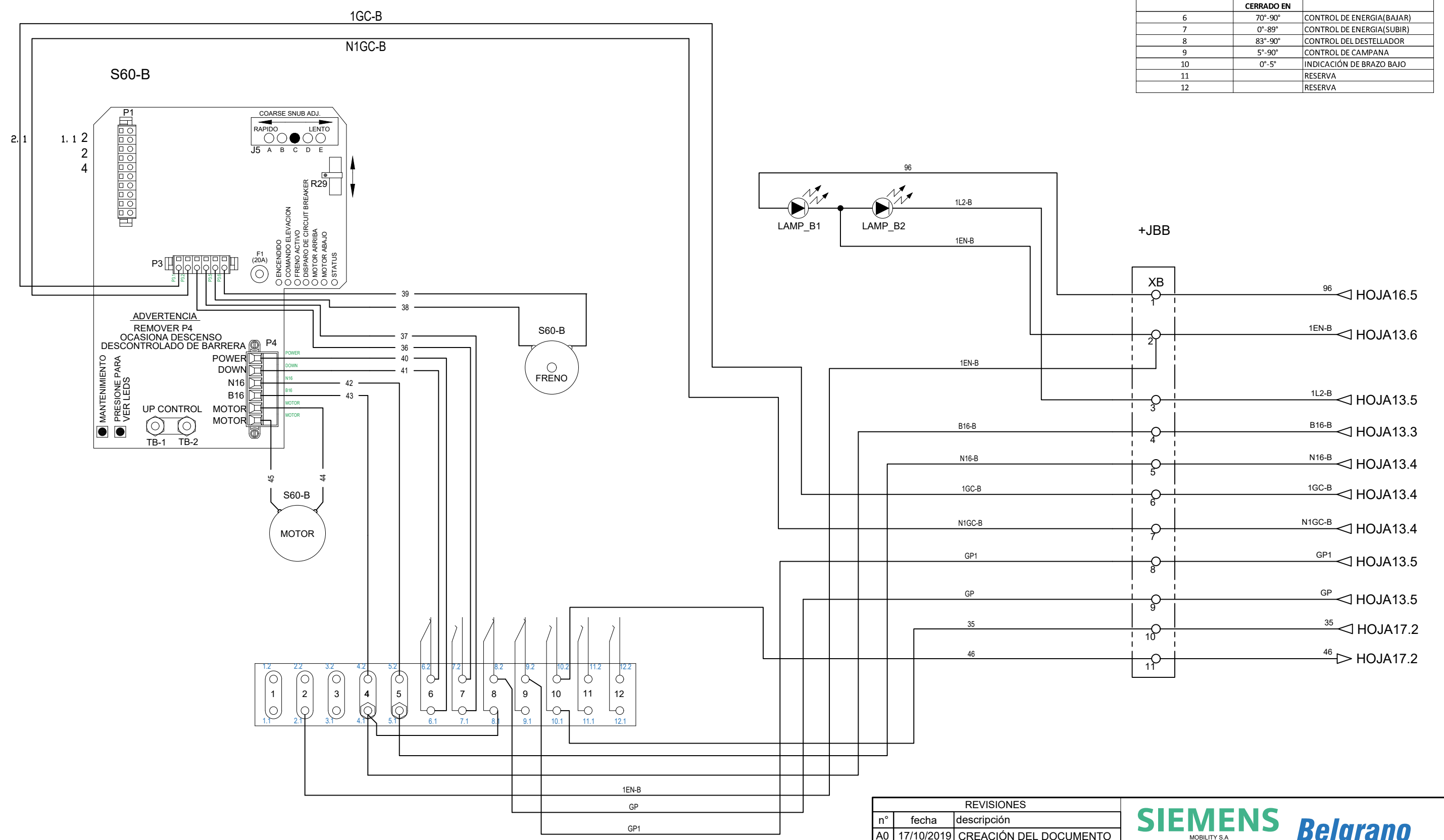

ADVERTENCIA
 REMOVER P4 OCASIONA DESCENSO DESCONTROLADO DE BARRERA

MANTENIMIENTO
 PRESIONE PARA VER LEDS

UP CONTROL
 TB-1 TB-2

POWER DOWN
 N16 B16 MOTOR MOTOR

COARSE SNUB ADJ.
 RAPIDO LENTO
 J5 A B C D E

ENCENDIDO
 COMANDO ELEVACION
 FRENO ACTIVO
 DISPARO DE CIRCUIT BREAKER
 MOTOR ARRIBA
 MOTOR ABAJO
 STATUS

REVISIONES		
n°	fecha	descripcion
A0	17/10/2019	CREACIÓN DEL DOCUMENTO



TITULO
ESQUEMAS FUNCIONALES PaN JM DE ROSAS

CLIENTE
BELGRANO CARGAS Y LOGISTICA

DESCRIPCIÓN
MECANISMO B

FECHA DE PLANO 17/10/2019 PLOT TIME:

DIB	LC	FECHA	17/10/2019	PROJ. NO.:	
REV	GM	FECHA DE EMISIÓN	17/10/2019	EST. NO.:	-
LIB	RA	N° DE DOCUMENTO	(3)59053C-S0170-A0	HOJA	14 DE 20

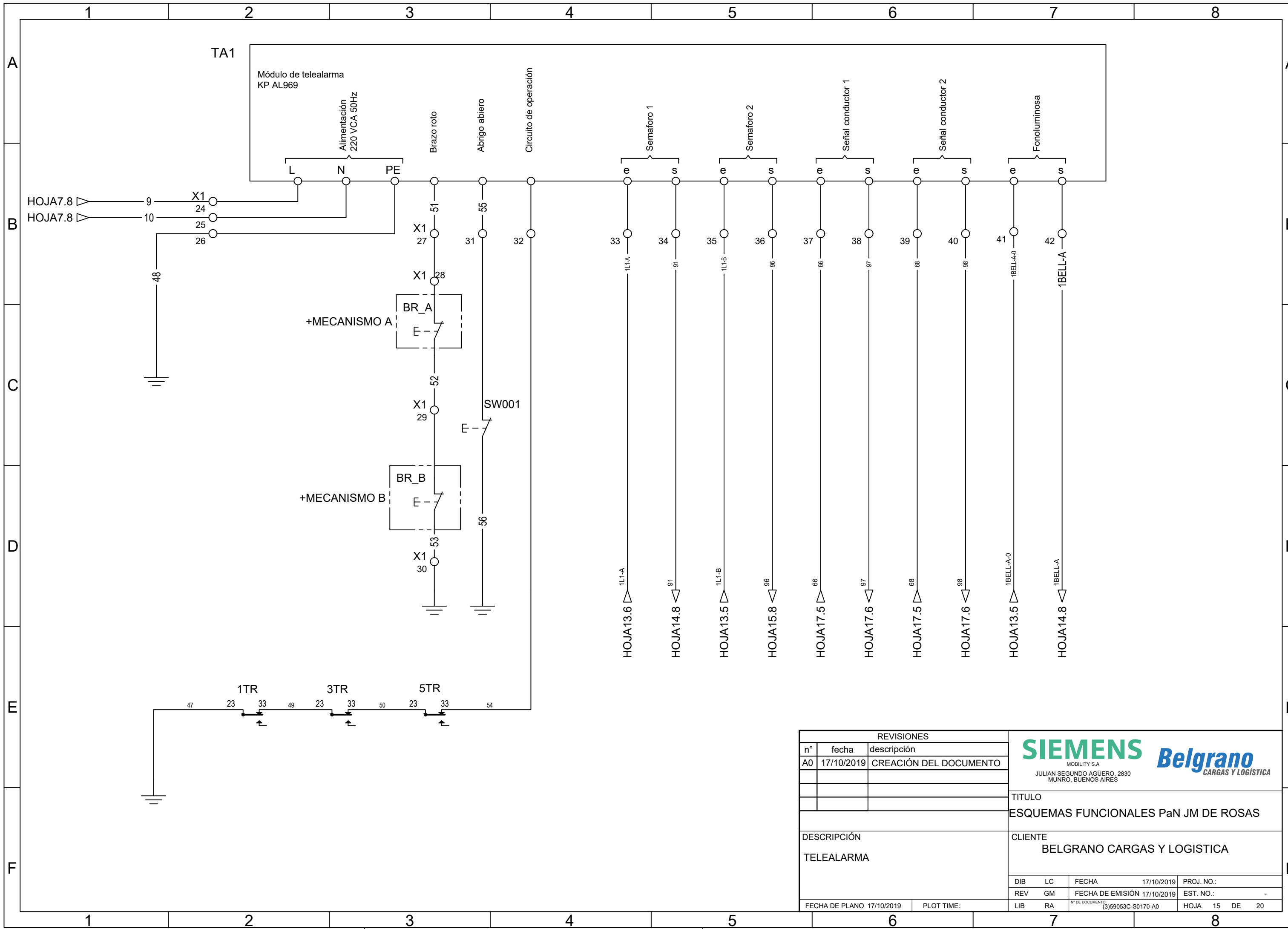

REVISIONES		
n°	fecha	descripción
A0	17/10/2019	CREACIÓN DEL DOCUMENTO
DESCRIPCIÓN		
TELEALARMA		
FECHA DE PLANO	17/10/2019	PLOT TIME:



TITULO			
ESQUEMAS FUNCIONALES PaN JM DE ROSAS			
CLIENTE			
BELGRANO CARGAS Y LOGISTICA			
DIB	LC	FECHA	17/10/2019
REV	GM	FECHA DE EMISIÓN	17/10/2019
LIB	RA	N° DE DOCUMENTO	(3)59053C-S0170-A0
PROJ. NO.:	EST. NO.:	HOJA	15 DE 20

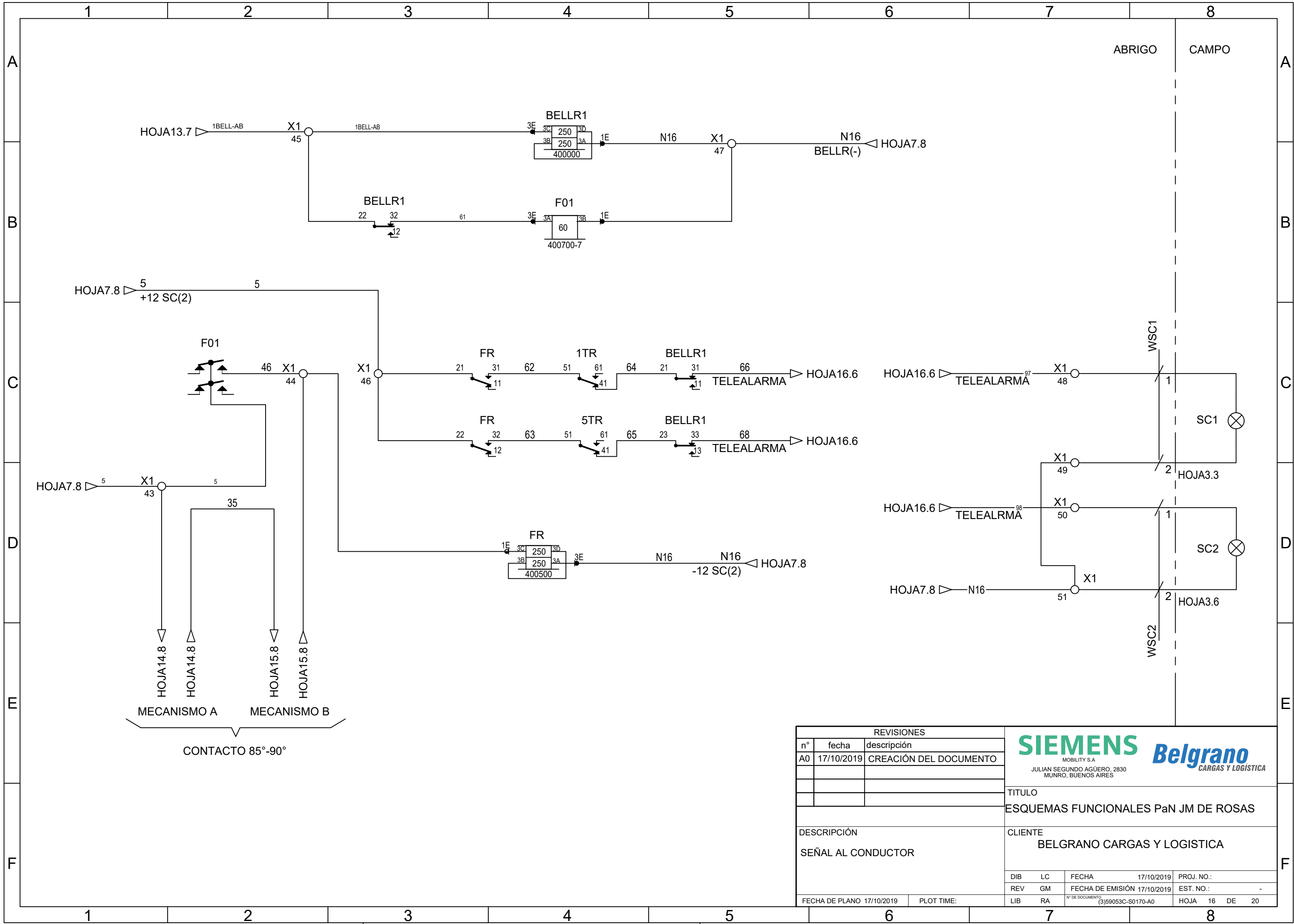

REVISIONES	
n°	fecha
A0	17/10/2019

SIEMENS *Belgrano*
MOBILITY S.A.
 JULIAN SEGUNDO AGÜERO, 2830
 MUNRO, BUENOS AIRES

TITULO
ESQUEMAS FUNCIONALES PaN JM DE ROSAS

CLIENTE
BELGRANO CARGAS Y LOGISTICA

DIB	LC	FECHA	17/10/2019	PROJ. NO.:	
REV	GM	FECHA DE EMISIÓN	17/10/2019	EST. NO.:	-
LIB	RA	N° DE DOCUMENTO	(3)59053C-S0170-A0	HOJA	16 DE 20

FECHA DE PLANO 17/10/2019 PLOT TIME:

Listado de componentes y cantidades

COMPONENTE	CANTIDAD	CATALOGO	DESCRIPCIÓN
BELLR1	1	400000	
FR	1	400500	
F01	1	400700-7X	
1TR 3TR 5TR	3	400010	
TRACK SP1	1	8000-80026-0035	
SP_SSCC	1	9000-91170-0001	
SSCC	1	9000-91190-1101	
S60-A S60-B	2	074600-W00110	
PS01	1	4000-44350-006X	
RA1.2 RA2.2 RA3.2	3	029603-2X	
RA1.1 RA2.1 RA3.1 RA4.1	4	029603-9X	

REVISIONES			
n°	fecha	descripción	
A0	17/10/2019	CREACIÓN DEL DOCUMENTO	

DESCRIPCIÓN
LISTA DE COMPONENTES



SIEMENS *Belgrano*
MOBILITY S.A.
JULIAN SEGUNDO AGÜERO, 2830
MUNRO, BUENOS AIRES

TITULO
ESQUEMAS FUNCIONALES PaN JM DE ROSAS

CLIENTE
BELGRANO CARGAS Y LOGISTICA

DIB	LC	FECHA	17/10/2019	PROJ. NO.:	
REV	GM	FECHA DE EMISIÓN	17/10/2019	EST. NO.:	-
LIB	RA	N° DE DOCUMENTO	(3)59053C-S0170-A0	HOJA	17 DE 20

Listado de cables y tipos

# multiconductor	tipo
W100	Multiconductor 2 X 6mm2
W200	Multiconductor 2 X 6mm2
W300	Multiconductor 2 X 6mm2
WA-1	MULTIFILAR 5x16mm2
WA-2	MULTIFILAR 4x2.5mm2
WB-1	MULTIFILAR 5x16mm2
WB-2	MULTIFILAR 4x2.5mm2
WSC1	Multifilar 2 x 2.5mm2
WSC2	Multifilar 2 x 2.5mm2

REVISIONES			
n°	fecha	descripción	
A0	17/10/2019	CREACIÓN DEL DOCUMENTO	



SIEMENS *Belgrano*
MOBILITY S.A
JULIAN SEGUNDO AGÜERO, 2830
MUNRO, BUENOS AIRES

TITULO
ESQUEMAS FUNCIONALES PaN JM DE ROSAS

CLIENTE
BELGRANO CARGAS Y LOGISTICA

DIB	LC	FECHA	17/10/2019	PROJ. NO.:	
REV	GM	FECHA DE EMISIÓN	17/10/2019	EST. NO.:	-
LIB	RA	N° DE DOCUMENTO	(3)59053C-S0170-A0	HOJA	18 DE 20

FECHA DE PLANO 17/10/2019 PLOT TIME:

LISTADO DE CABLES DESDE HASTA

#CABLE	COMPONENTE 1	PIN1	COMPONENTE 2	PIN2	
1	X1	1	T03		
1	X1	1	T01		
1	BELL-A	TA1	X1	50	
1	BELL-A-0	TA1	X1	49	
1	BELL-A-0	SP_SSCC	1 BELL-A	X1	49
1	BELL-AB	X1	31	X1	53
1	BELL-AB	X1	31	SP_SSCC	1 BELL
1	BELL-AB	X1	53	BELLR1	3E
1	BELL-AB	X1	53	BELLR1	22
1	BELL-AB	SSCC	J1-3	X1	31
1	GC-AB	SSCC	J1-1	SP_SSCC	1 GC (+)
1	L1	SSCC	J1-5	SP_SSCC	1L1
1	L1-A	TA1		X1	41
1	L1-A	SP_SSCC	1L1 NEAR	X1	41
1	L1-B	TA1		X1	43
1	L1-B	SP_SSCC	1L1FAR	X1	43
1	L2	SSCC	J1-7	SP_SSCC	1L2
2	X1	4	T03		
2	X1	4	T01		
3	T01		X1	2	
3	3TR	1E	TRACK SP1		
3	X1	2	CB1	L	
4	RA2.1		RA4.1		
4	RA4.1		RA2.2		
4	RA2.2		TRACK SP1		
4	CB1	+	X1	3	
4	X1	3	BT1		
5	BT1		X1	6	
5	CB1	-	X1	7	
5	CB1	-	X1	6	
5	X1	7	X1	21	
5	X1	7	X1	8	
5	X1	8	SP_SSCC		
5	X1	8	X1	9	
5	X1	9	X1	51	
5	X1	9	X1	10	
5	X1	10	PS01		
5	X1	10	X1	11	
5	X1	11	X1	54	
5	X1	21	1TR	22	
5	X1	21	X1	22	
5	X1	22	3TR	21	
5	X1	22	5TR	21	
5	X1	51	F01		
6	PS01		1TR	1E	
6	1TR	1E	TRACK SP1		
8	1TR	32	SSCC	J4-4	
9	T03		X1	17	
9	X1	17	X1	32	
9	X1	32	TA1		

#CABLE	COMPONENTE 1	PIN1	COMPONENTE 2	PIN2
10	T03		X1	18
10	X1	18	X1	33
10	X1	33	TA1	
16	PS01		5TR	1E
16	5TR	1E	TRACK SP1	
21	3TR	31	SSCC	J4-6
46	F01		X1	52
47			1TR	23
48			X1	34
48	X1	34	TA1	
49	1TR	33	3TR	23
50	3TR	33	5TR	23
51	TA1		X1	35
51	X1	35	X1	36
53	X1	38		
54	TA1		X1	40
54	5TR	33	X1	40
55	TA1		X1	39
55	X1	39	SW001	
56	SW001			
57	5TR	31	SSCC	J3-2
61	BELLR1	32	F01	3E
64	1TR	41	BELLR1	21
65	5TR	41	BELLR1	23
66	TA1		X1	45
66	BELLR1	31	X1	45
68	TA1		X1	47
68	BELLR1	33	X1	47
73	PS01		RA1.1	
74	PS01		RA2.1	
75	PS01		RA3.1	
76	PS01		RA4.1	
88	RA1.1		RA1.2	
88	RA1.2		TRACK SP1	
89	RA3.1		RA3.2	
89	RA3.2		TRACK SP1	
91	TA1		X1	42
93	1TR	3E	RA1.2	
96	TA1		X1	44
97	TA1		X1	46
97	X1	46	X1	56
98	TA1		X1	48
98	X1	48	X1	58
99	3TR	3E	RA2.2	
101	5TR	3E	RA3.2	
B16	SP_SSCC	B-BATT	SSCC	J2-2
B16	SP_SSCC	B-BATT	SSCC	J2-1
GP	SSCC	J3-12	SP_SSCC	GP
N1GC-AB	SSCC	J1-2	SP_SSCC	1 GC (-)
N16	T01		X1	5

#CABLE	COMPONENTE 1	PIN1	COMPONENTE 2	PIN2
N16	F01	1E	X1	55
N16	BELLR1	1E	X1	55
N16	X1	5	CB1	N
N16	X1	12	PS01	
N16	X1	12	X1	13
N16	X1	13	X1	26
N16	X1	13	X1	14
N16	X1	14	SP_SSCC	N-BATT
N16	X1	14	X1	15
N16	X1	15	X1	55
N16	X1	15	X1	16
N16	X1	16	X1	59
N16	X1	26	X1	27
N16	X1	27	SSCC	J3-1
N16	X1	57	X1	59
N16	SSCC	J4-3	X1	26
N16	SSCC	J4-5	X1	27
N16	CB1	N	X1	12
N16	SP_SSCC	N-1	SSCC	J3-11
N16	SP_SSCC	N-EQPT	SSCC	J2-5
N16	SP_SSCC	N-EQPT	SSCC	J2-4

REVISIONES			
n°	fecha	descripción	
A0	17/10/2019	CREACIÓN DEL DOCUMENTO	
DESCRIPCIÓN		CLIENTE	
LISTA DESDE HASTA		BELGRANO CARGAS Y LOGISTICA	
DIB	LC	FECHA	17/10/2019
REV	GM	FECHA DE EMISIÓN	17/10/2019
FECHA DE PLANO		PLOT TIME:	
17/10/2019			



TITULO
ESQUEMAS FUNCIONALES PaN JM DE ROSAS

CLIENTE
BELGRANO CARGAS Y LOGISTICA

DIB LC FECHA 17/10/2019 PROJ. NO.:
REV GM FECHA DE EMISIÓN 17/10/2019 EST. NO.: -
LIB RA N° DE DOCUMENTO (3)59053C-S0170-A0 HOJA 19 DE 20

BORNERAS

X1

1,T03 1	1	1 T01
T01 3	2	3 CB1:L
CB1+ 4	3	4 BT1
2,T03 2	4	2 T01
T01 N16	5	N16 CB1:N
BT1 5	6	5 CB1:-
CB1- 5;X1:19 5	7	5 X1:8
X1:7 5;SP_SSCC 5	8	5 X1:9
X1:8 5;X1:4:3 5	9	5 X1:10
X1:9 5;PS01 5	10	5 X1:11
X1:10 5;X1:4:6 5	11	5
CB1:N N16;X1:13 N16	12	N16 ;N16 PS01
X1:12 N16;X1:21 N16	13	N16 X1:14
X1:13 N16;SP_SSCC-N-BATT N16	14	N16 X1:15
X1:14 N16;X1:4:7 N16	15	N16 X1:16
X1:15 N16;X1:5:1 N16	16	N16 FR:3E
T03 9	17	9 X1:24
T03 10	18	10 X1:25
X1:7 5;1TR:22 5	19	5 X1:20
X1:19 5;3TR:21 5	20	5 5TR:21
X1:13 N16;X1:22 N16	21	N16 SSCC:J4-3
X1:21 N16;SSCC:J3-1 N16	22	N16 SSCC:J4-5
SSCC:J1-3 1BELL-AB;X1:4:5 1BELL-AB	23	1BELL-AB SP_SSCC:1 BELL
X1:17 9	24	9 TA1
X1:18 10	25	10 TA1
48	26	48 TA1
TA1 51	27	51 X1:28
X1:27 51	28	51 BR_A
BR_A 52	29	52 BR_B
BR_B 53	30	53
TA1 55	31	55 SW001
5TR:33 54	32	54 TA1
SP_SSCC:1L1 NEAR 1L1-A	33	1L1-A TA1
XA:1 91	34	91 TA1
SP_SSCC:1L1FAR 1L1-B	35	1L1-B TA1
XB:1 96	36	96 TA1
TA1 66	37	66 BELLR1:31
TA1 97	38	97 X1:48
TA1 68	39	68 BELLR1:33
TA1 98	40	98 X1:50
SP_SSCC:1 BELL-A 1BELL-A-0	41	1BELL-A-0 TA1
XA:8 1BELL-A	42	1BELL-A TA1
X1:9 5;F01 5	43	5 XA:10
XB:11 46;FR:1E 46	44	46 F01
X1:23 1BELL-AB;BELLR1:3E 1BELL-AB	45	1BELL-AB BELLR1:22
X1:11 5;FR:21 5	46	5 FR:22
X1:15 N16;F01:1E N16	47	N16 BELLR1:1E
X1:38 97	48	97 SC1
X1:51 N16	49	N16 SC1
X1:40 98	50	98 SC2
X1:16 N16;SC2 N16	51	N16 X1:49

REVISIONES			
n°	fecha	descripción	
A0	17/10/2019	CREACIÓN DEL DOCUMENTO	
DESCRIPCIÓN			 <p>MOBILITY S.A JULIAN SEGUNDO AGÜERO, 2830 MUNRO, BUENOS AIRES</p>
BORNERAS			
TITULO			ESQUEMAS FUNCIONALES PaN JM DE ROSAS
CLIENTE			
BELGRANO CARGAS Y LOGISTICA			
DIB	LC	FECHA	17/10/2019
REV	GM	FECHA DE EMISIÓN	17/10/2019
FECHA DE PLANO		17/10/2019	PLOT TIME:
LIB	RA	N° DE DOCUMENTO	(3)59053C-S0170-A0
PROJ. NO.:		EST. NO.:	
HOJA		20	DE 20