

Belgrano Cargas Y Logística

Provisión de equipos para automatización de pasos a nivel

Líneas San Marín y Belgrano

Esquemas funcionales PaN Pellegrini

| REVISIONES | | | |
|------------|------------|------------------------|--|
| n° | fecha | descripción | |
| A0 | 17/10/2019 | CREACIÓN DEL DOCUMENTO | |
| | | | |
| | | | |
| | | | |

| | | | |
|--|----|------------------|--------------------|
| SIEMENS <i>Belgrano</i> <small>MOBILITY S.A. JULIAN SEGUNDO AGÜERO, 2830 MUNRO, BUENOS AIRES</small> | | | |
| TITULO ESQUEMAS FUNCIONALES PaN PELLEGRINI | | | |
| DESCRIPCIÓN CARATULA DEL DOCUMENTO | | | |
| CLIENTE BELGRANO CARGAS Y LOGISTICA | | | |
| DIB | LC | FECHA | 17/10/2019 |
| REV | GM | FECHA DE EMISIÓN | 17/10/2019 |
| LIB | RA | N° DE DOCUMENTO | (3)59053C-S0150-A0 |
| FECHA DE PLANO | | PLOT TIME: | |
| 17/10/2019 | | | |
| PROJ. NO.: | | EST. NO.: | |
| | | - | |
| HOJA | | DE | |
| 1 | | 23 | |

Listado de contenidos en este documento

| HOJA | DESCRIPCIÓN |
|------|----------------------------|
| 1 | CARATULA DEL DOCUMENTO |
| 2 | LISTA DE CONTENIDOS |
| 3 | TRACK LAYOUT (ESQUEMÁTICO) |
| 4 | TOPOGRÁFICO RACK |
| 5 | ABRIGO - VISTA EN PLANTA |
| 6 | VISTA CARGADOR |
| 7 | CARGADORES Y BATERÍAS |
| 8 | FUENTE CDV C |
| 9 | SALIDA A CAMPO |
| 10 | SALIDA A CAMPO 2 |
| 11 | CIRCUITOS DE VÍA |
| 12 | SSCC |
| 13 | PROTECCIONES S60 |
| 14 | MECANISMO A |
| 15 | MECANISMO B |
| 16 | TELEALARMA |
| 17 | SEÑAL AL CONDUCTOR |
| 18 | CONTROL MAUAL DE BARRERA |
| 19 | LISTA DE COMPONENTES |
| 20 | LISTADO DE CABLES Y TIPO |
| 21 | LISTA DESDE HASTA |
| 22 | DESDE HASTA HOJA 2 |
| 23 | BORNERAS |

| REVISIONES | | | |
|---------------------|------------|------------------------|------------------|
| n° | fecha | descripción | |
| A0 | 17/10/2019 | CREACIÓN DEL DOCUMENTO | |
| | | | |
| | | | |
| | | | |
| DESCRIPCIÓN | | | |
| LISTA DE CONTENIDOS | | | |
| DIB | | LC | FECHA |
| REV | | GM | FECHA DE EMISIÓN |
| LIB | | RA | N° DE DOCUMENTO |
| FECHA DE PLANO | | PLOT TIME: | |
| 17/10/2019 | | | |
| PROJ. NO.: | | EST. NO.: | |
| | | - | |
| HOJA | | DE | |
| 2 | | 23 | |



TITULO
ESQUEMAS FUNCIONALES PaN PELLEGRINI

CLIENTE
BELGRANO CARGAS Y LOGISTICA

1 2 3 4 5 6 7 8

A

A

B

B

C

C

D

D

E

E

F

F

1 2 3 4 5 6 7 8

PaN Pelegrini
PK 209+300

MDZ

BS AS

MECANISMO "A"

2 1

WA-2

WA-1

SC1

204T

tx

203T

tx

107T

tx

1T

tx

106T

tx

105T

tx

tx

tx

104T

ABRIGO

W700

W600

W500

W400

W300

W200

W100

WSC2

WSC1

SUMINISTRO
DE 220 MONOFAS CC
POR BCyL

MECANISMO "B"

1 2

WB-1

WB-2

SC2

| REVISIONES | | |
|----------------------------|------------|------------------------|
| n° | fecha | descripción |
| A0 | 17/10/2019 | CREACIÓN DEL DOCUMENTO |
| | | |
| | | |
| | | |
| DESCRIPCIÓN | | |
| TRACK LAYOUT (ESQUEMÁTICO) | | |
| FECHA DE PLANO | 17/10/2019 | PLOT TIME: |

SIEMENS *Belgrano*
MOBILITY S.A.
JULIAN SEGUNDO AGÜERO, 2830
MUNRO, BUENOS AIRES
CARGAS Y LOGÍSTICA

TITULO
ESQUEMAS FUNCIONALES PaN PELLEGRINI

CLIENTE
BELGRANO CARGAS Y LOGISTICA

| | | | | | |
|-----|----|------------------|--------------------|------------|---------|
| DIB | LC | FECHA | 17/10/2019 | PROJ. NO.: | |
| REV | GM | FECHA DE EMISIÓN | 17/10/2019 | EST. NO.: | - |
| LIB | RA | N° DE DOCUMENTO | (3)59053C-S0150-A0 | HOJA | 3 DE 23 |

VISTA GENERAL DEL RACK

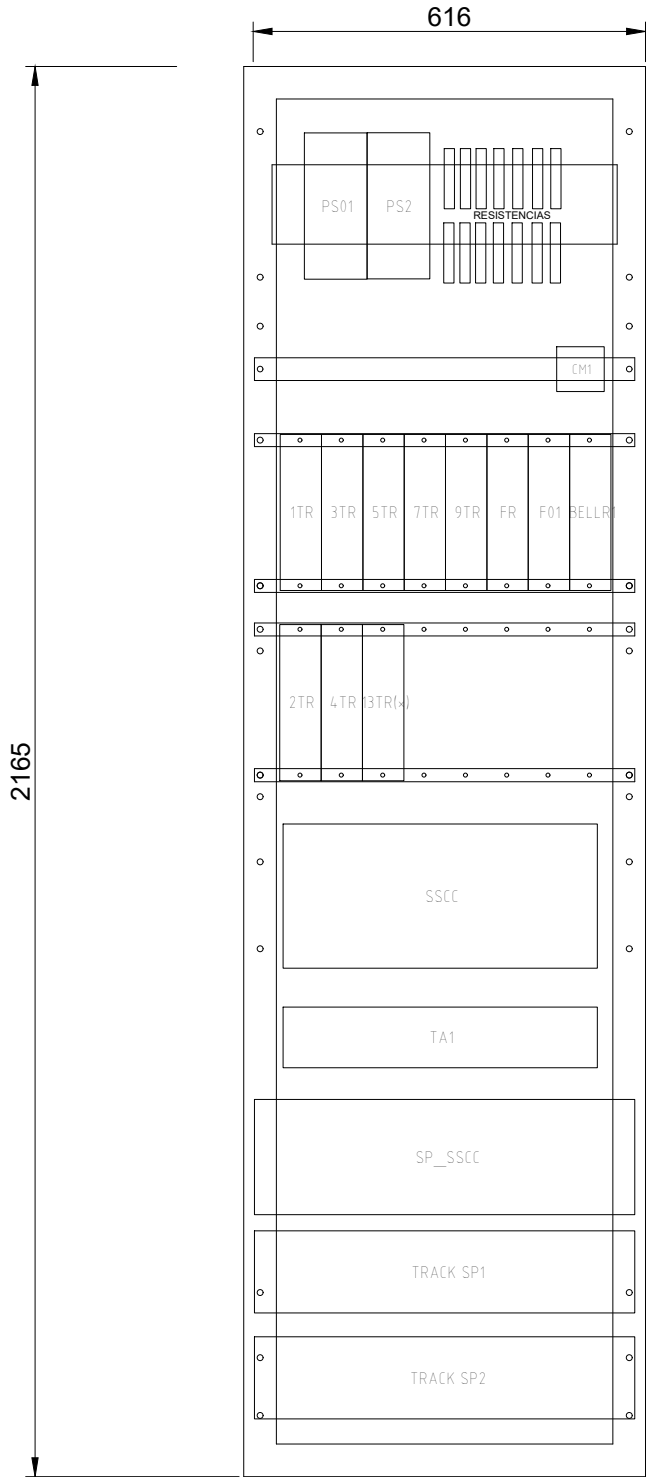

| REVISIONES | | |
|------------------|------------|------------------------|
| n° | fecha | descripción |
| A0 | 17/10/2019 | CREACIÓN DEL DOCUMENTO |
| | | |
| | | |
| | | |
| DESCRIPCIÓN | | |
| TOPOGRÁFICO RACK | | |
| FECHA DE PLANO | 17/10/2019 | PLOT TIME: |



| | | | |
|-------------------------------------|----|------------------|--------------------|
| TITULO | | | |
| ESQUEMAS FUNCIONALES PaN PELLEGRINI | | | |
| CLIENTE | | | |
| BELGRANO CARGAS Y LOGISTICA | | | |
| DIB | LC | FECHA | 17/10/2019 |
| REV | GM | FECHA DE EMISIÓN | 17/10/2019 |
| LIB | RA | N° DE DOCUMENTO | (3)59053C-S0150-A0 |
| PROJ. NO.: | | EST. NO.: | - |
| HOJA | 4 | DE | 23 |

VISTA EN PLANTA DEL ABRIGO DE CONTROL

Tablero de distribución (*)

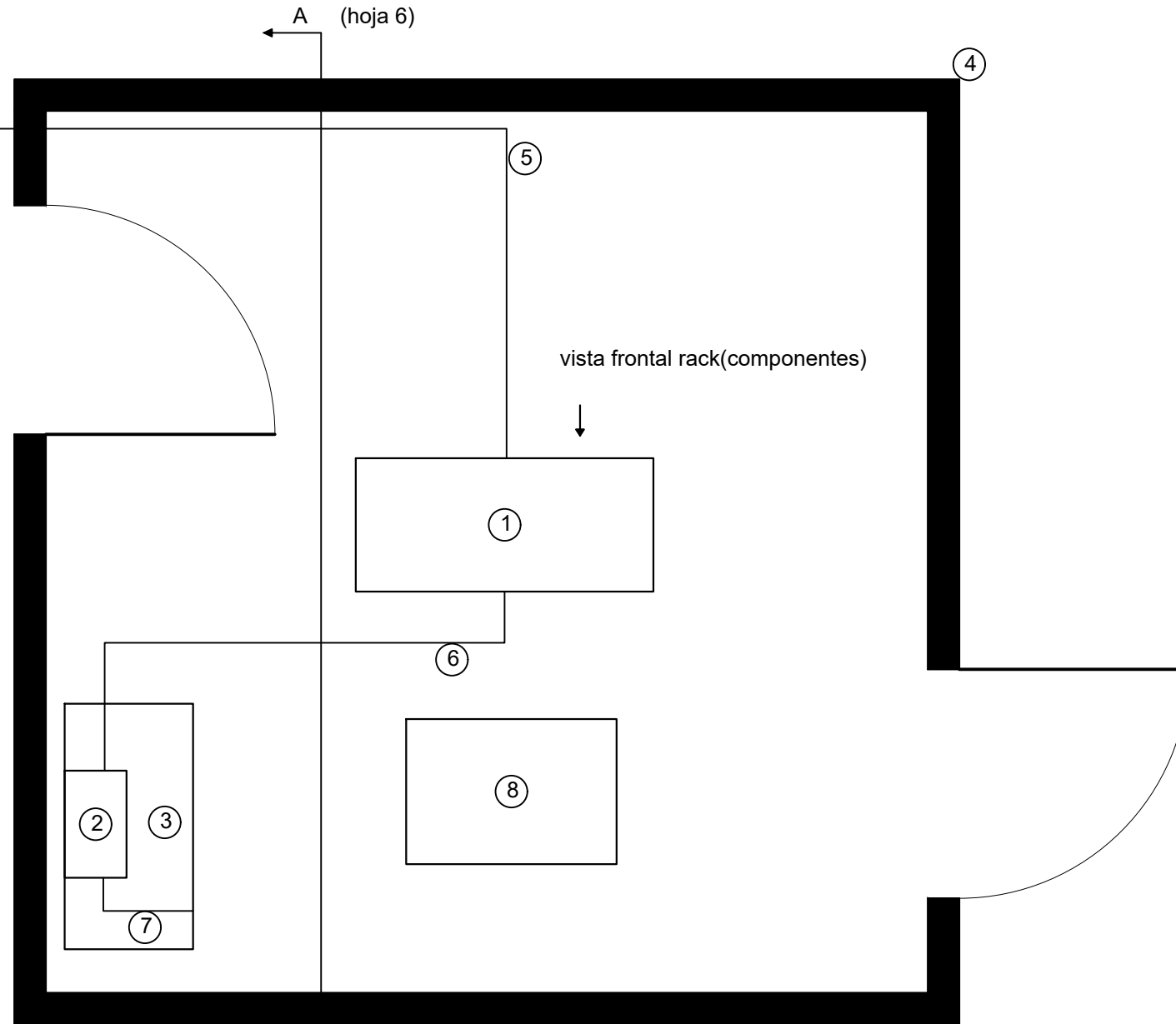

| REFERENCIAS | |
|-------------|--|
| 1 | RACK DE CONTROL PaN |
| 2 | CARGADOR 12V |
| 3 | BANCO DE BATERÍAS 12V |
| 4 | TÍPICO DE ABRIGO - (3)59053C-C0004-A0 |
| 5 | ALIMENTACIÓN PPAL |
| 6 | SALIDA DE CONSUMOS DEL CARGADOR 12 VDC |
| 7 | LÍNEA DE CARGA DE BATERÍAS |
| 8 | SALIDA DE CABLES A CAMPO |

(*) el tablero de distribución general podrá estar dentro del abrigo

| REVISIONES | | |
|--------------------------|------------|------------------------|
| n° | fecha | descripción |
| A0 | 17/10/2019 | CREACIÓN DEL DOCUMENTO |
| | | |
| | | |
| | | |
| | | |
| DESCRIPCIÓN | | |
| ABRIGO - VISTA EN PLANTA | | |
| FECHA DE PLANO | 17/10/2019 | PLOT TIME: |



TITULO
ESQUEMAS FUNCIONALES PaN PELLEGRINI

CLIENTE
BELGRANO CARGAS Y LOGISTICA

| | | | | | |
|-----|----|------------------|--------------------|------------|---------|
| DIB | LC | FECHA | 17/10/2019 | PROJ. NO.: | |
| REV | GM | FECHA DE EMISIÓN | 17/10/2019 | EST. NO.: | - |
| LIB | RA | N° DE DOCUMENTO | (3)59053C-S0150-A0 | HOJA | 5 DE 23 |

VISTA A-A - INSTALACIÓN EN PARED DEL CARTGADOR 12VDC

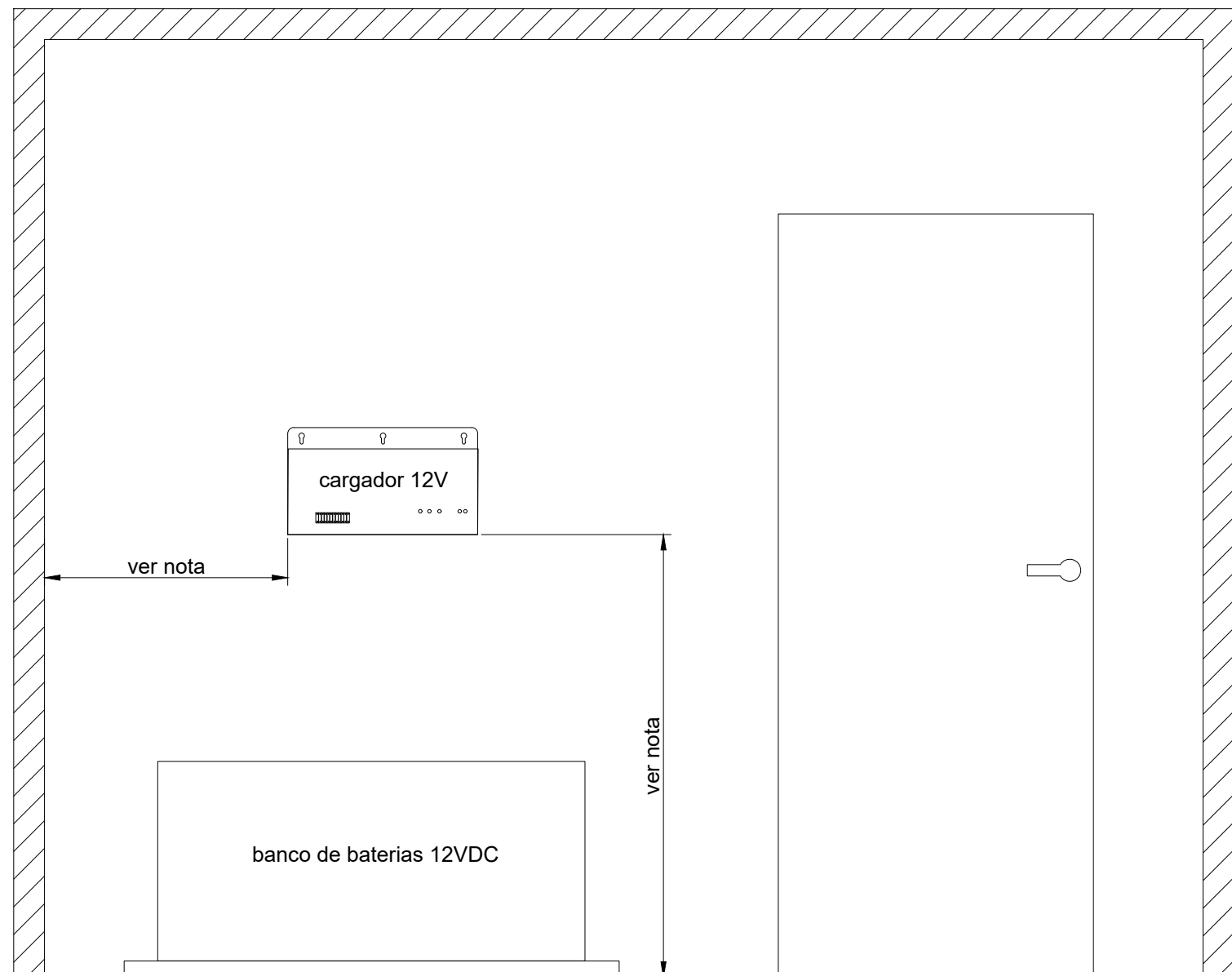

Nota: Las posiciones finales de los equipos de referencia serán determinadas en la próxima revisión.

Este plano es indicativo, no está a escala

| REVISIONES | | |
|----------------|------------|------------------------|
| n° | fecha | descripción |
| A0 | 17/10/2019 | CREACIÓN DEL DOCUMENTO |
| | | |
| | | |
| | | |
| DESCRIPCIÓN | | |
| VISTA CARGADOR | | |
| FECHA DE PLANO | 17/10/2019 | PLOT TIME: |

SIEMENS *Belgrano*
 MOBILITY S.A
 JULIAN SEGUNDO AGÜERO, 2830
 MUNRO, BUENOS AIRES

TITULO
 ESQUEMAS FUNCIONALES PaN PELLEGRINI

CLIENTE
 BELGRANO CARGAS Y LOGISTICA

| | | | | | |
|-----|----|------------------|--------------------|------------|---------|
| DIB | LC | FECHA | 17/10/2019 | PROJ. NO.: | |
| REV | GM | FECHA DE EMISIÓN | 17/10/2019 | EST. NO.: | - |
| LIB | RA | N° DE DOCUMENTO | (3)59053C-S0150-A0 | HOJA | 6 DE 23 |

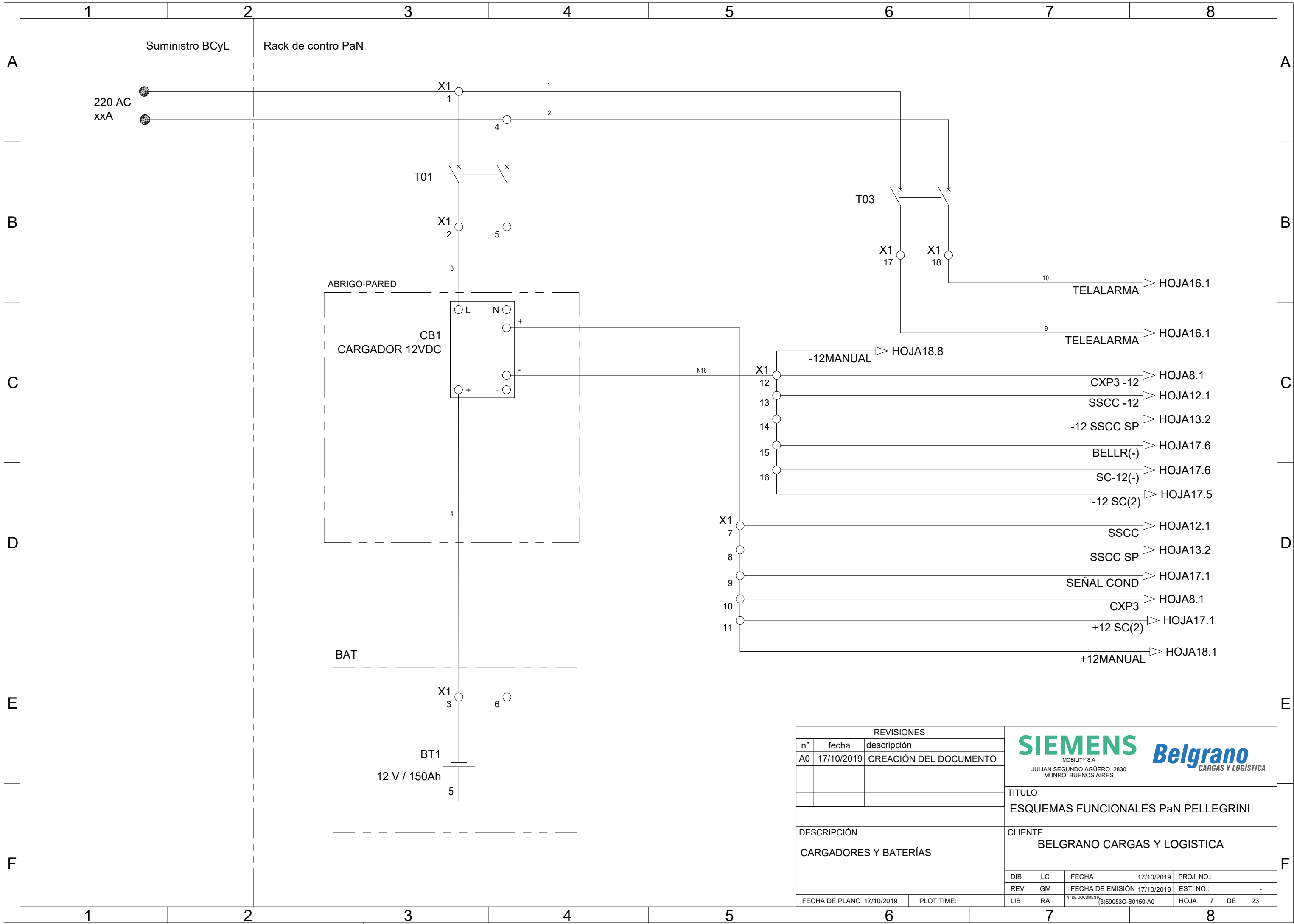

| REVISIONES | | |
|-----------------------|------------|------------------------|
| n° | fecha | descripción |
| A0 | 17/10/2019 | CREACIÓN DEL DOCUMENTO |
| | | |
| | | |
| | | |
| | | |
| DESCRIPCIÓN | | |
| CARGADORES Y BATERÍAS | | |
| FECHA DE PLANO | 17/10/2019 | PLOT TIME: |



| | | | |
|-------------------------------------|-----------|------------------|--------------------|
| TITULO | | | |
| ESQUEMAS FUNCIONALES PaN PELLEGRINI | | | |
| CLIENTE | | | |
| BELGRANO CARGAS Y LOGISTICA | | | |
| DIB | LC | FECHA | 17/10/2019 |
| REV | GM | FECHA DE EMISIÓN | 17/10/2019 |
| LIB | RA | N° DE DOCUMENTO | (3)59053C-S0150-A0 |
| PROJ. NO.: | EST. NO.: | HOJA | 7 DE 23 |

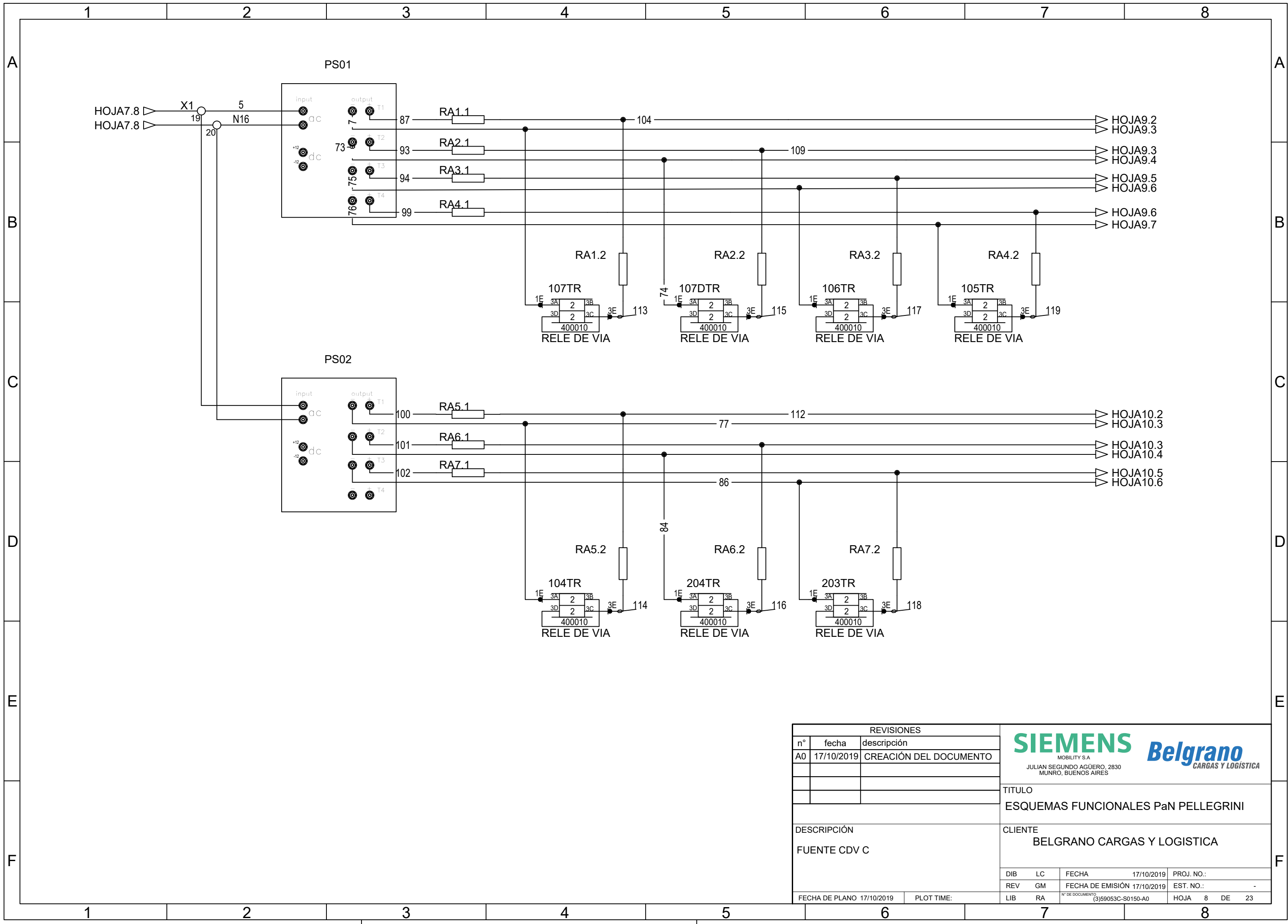

| REVISIONES | | |
|----------------|------------|------------------------|
| n° | fecha | descripción |
| A0 | 17/10/2019 | CREACIÓN DEL DOCUMENTO |
| | | |
| | | |
| | | |
| DESCRIPCIÓN | | |
| FUENTE CDV C | | |
| FECHA DE PLANO | 17/10/2019 | PLOT TIME: |



| | | | |
|-------------------------------------|----|------------------|--------------------|
| TITULO | | | |
| ESQUEMAS FUNCIONALES PaN PELLEGRINI | | | |
| CLIENTE | | | |
| BELGRANO CARGAS Y LOGISTICA | | | |
| DIB | LC | FECHA | 17/10/2019 |
| REV | GM | FECHA DE EMISIÓN | 17/10/2019 |
| LIB | RA | N° DE DOCUMENTO | (3)59053C-S0150-A0 |
| | | PROJ. NO.: | |
| | | EST. NO.: | - |
| | | HOJA | 8 DE 23 |

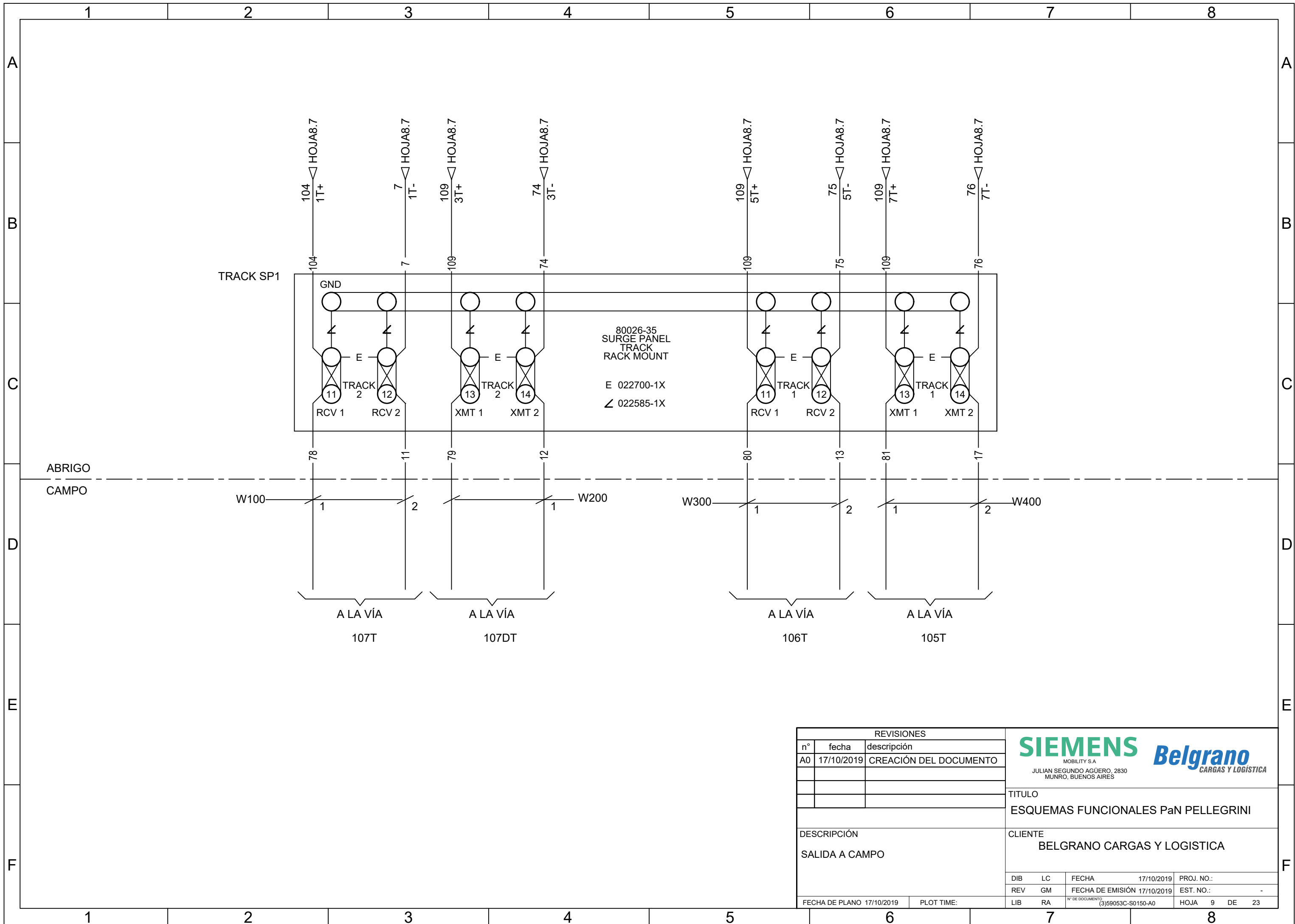

| REVISIONES | | |
|----------------|------------|------------------------|
| n° | fecha | descripción |
| A0 | 17/10/2019 | CREACIÓN DEL DOCUMENTO |
| | | |
| | | |
| | | |
| DESCRIPCIÓN | | |
| SALIDA A CAMPO | | |
| FECHA DE PLANO | 17/10/2019 | PLOT TIME: |



| | | | |
|-------------------------------------|----|------------------|--------------------|
| TITULO | | | |
| ESQUEMAS FUNCIONALES PaN PELLEGRINI | | | |
| CLIENTE | | | |
| BELGRANO CARGAS Y LOGISTICA | | | |
| DIB | LC | FECHA | 17/10/2019 |
| REV | GM | FECHA DE EMISIÓN | 17/10/2019 |
| LIB | RA | N° DE DOCUMENTO | (3)59053C-S0150-A0 |
| PROJ. NO.: | | EST. NO.: | |
| | | - | |
| HOJA | | 9 DE 23 | |

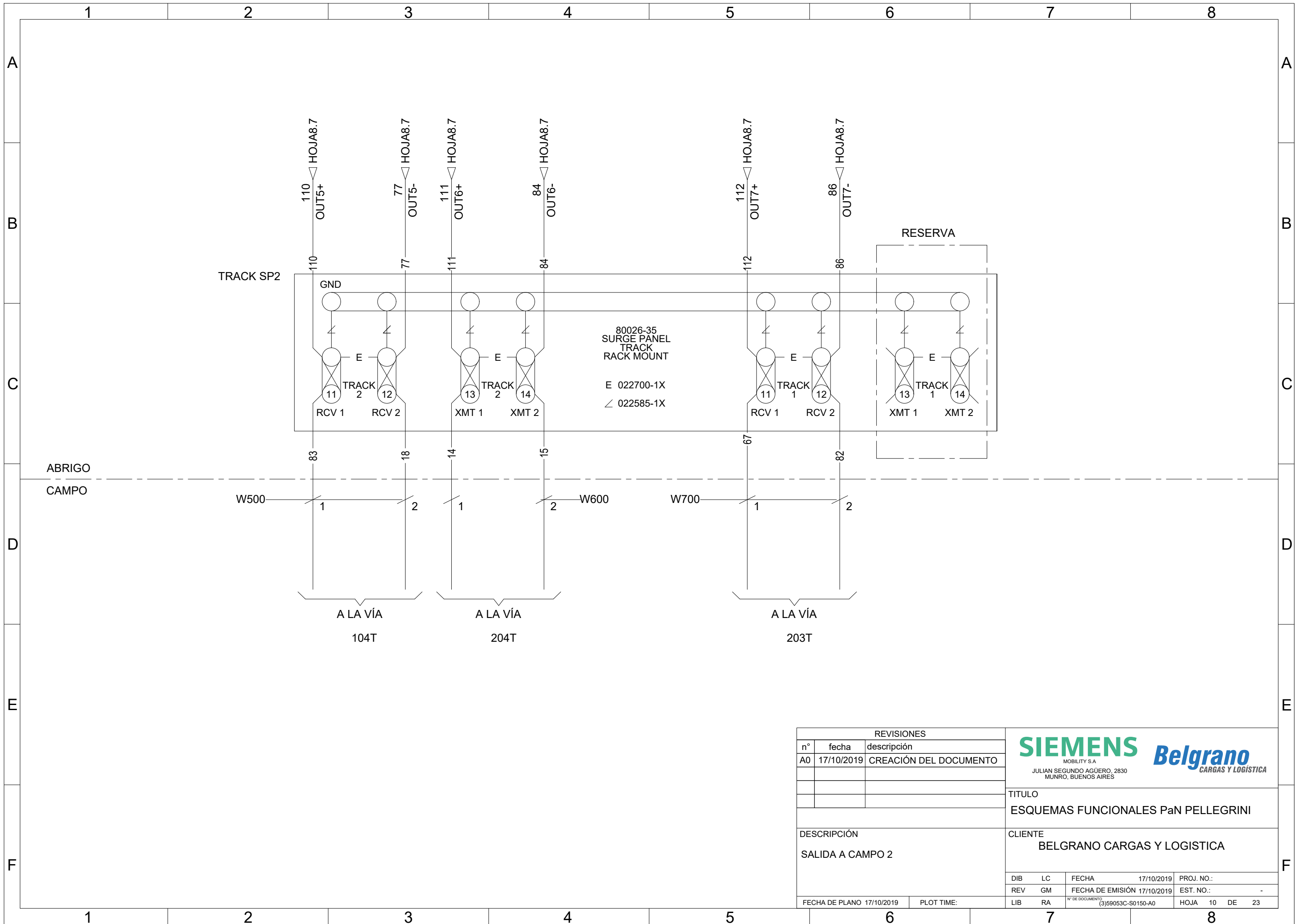

| REVISIONES | | |
|------------------|------------|------------------------|
| n° | fecha | descripción |
| A0 | 17/10/2019 | CREACIÓN DEL DOCUMENTO |
| | | |
| | | |
| | | |
| DESCRIPCIÓN | | |
| SALIDA A CAMPO 2 | | |
| FECHA DE PLANO | 17/10/2019 | PLOT TIME: |



| | | | |
|-------------------------------------|----|------------------|--------------------|
| TITULO | | | |
| ESQUEMAS FUNCIONALES PaN PELLEGRINI | | | |
| CLIENTE | | | |
| BELGRANO CARGAS Y LOGISTICA | | | |
| DIB | LC | FECHA | 17/10/2019 |
| REV | GM | FECHA DE EMISIÓN | 17/10/2019 |
| LIB | RA | N° DE DOCUMENTO | (3)59053C-S0150-A0 |
| PROJ. NO.: | | EST. NO.: | |
| | | - | |
| HOJA | | 10 DE 23 | |

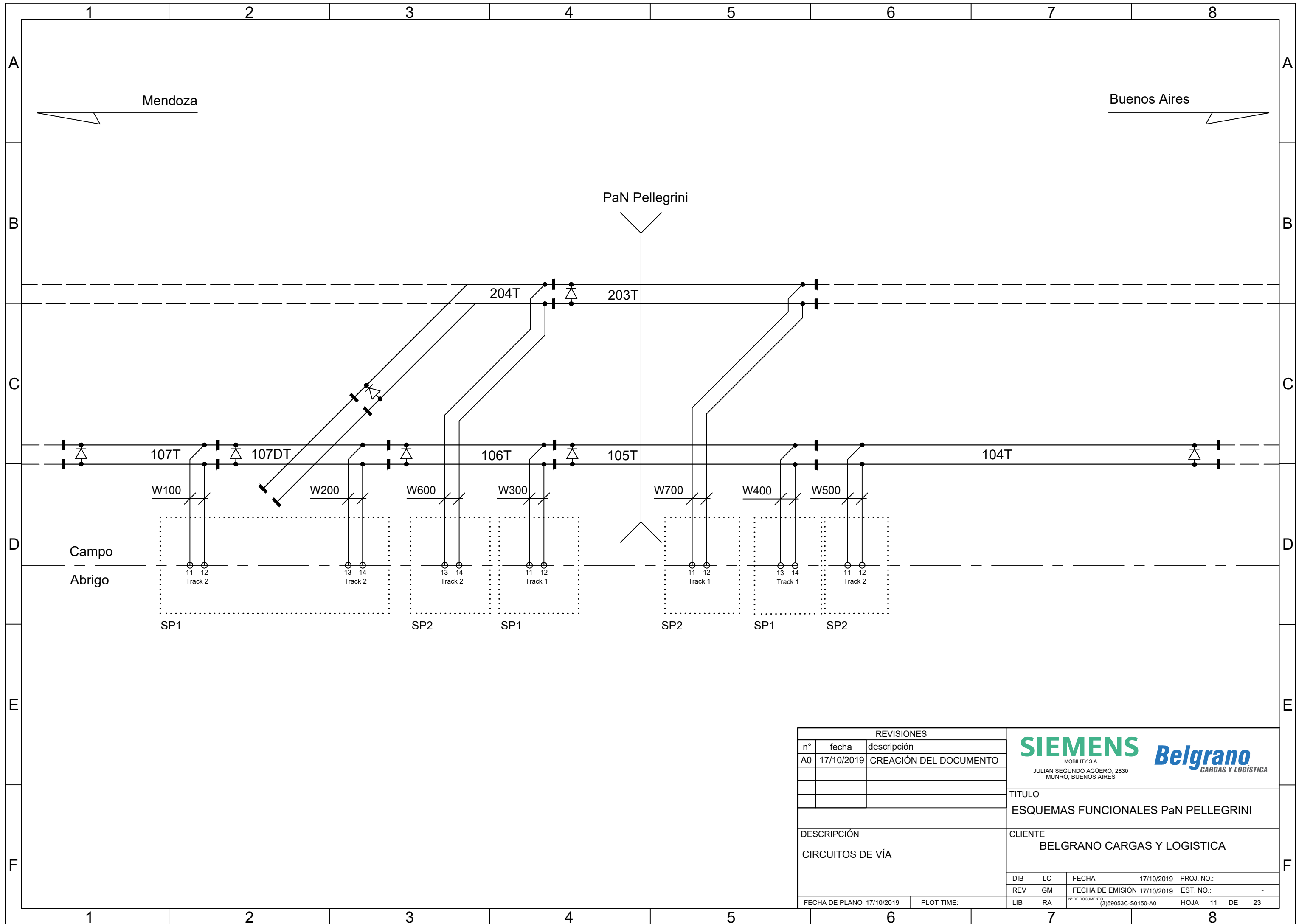

| REVISIONES | | |
|------------------|------------|------------------------|
| n° | fecha | descripción |
| A0 | 17/10/2019 | CREACIÓN DEL DOCUMENTO |
| | | |
| | | |
| | | |
| DESCRIPCIÓN | | |
| CIRCUITOS DE VÍA | | |
| FECHA DE PLANO | 17/10/2019 | PLOT TIME: |

SIEMENS *Belgrano*
MOBILITY S.A.
 JULIAN SEGUNDO AGÜERO, 2830
 MUNRO, BUENOS AIRES

TITULO
ESQUEMAS FUNCIONALES PaN PELLEGRINI

CLIENTE
BELGRANO CARGAS Y LOGISTICA

| | | | | | |
|-----|----|------------------|--------------------|------------|----------|
| DIB | LC | FECHA | 17/10/2019 | PROJ. NO.: | |
| REV | GM | FECHA DE EMISIÓN | 17/10/2019 | EST. NO.: | - |
| LIB | RA | N° DE DOCUMENTO | (3)59053C-S0150-A0 | HOJA | 11 DE 23 |

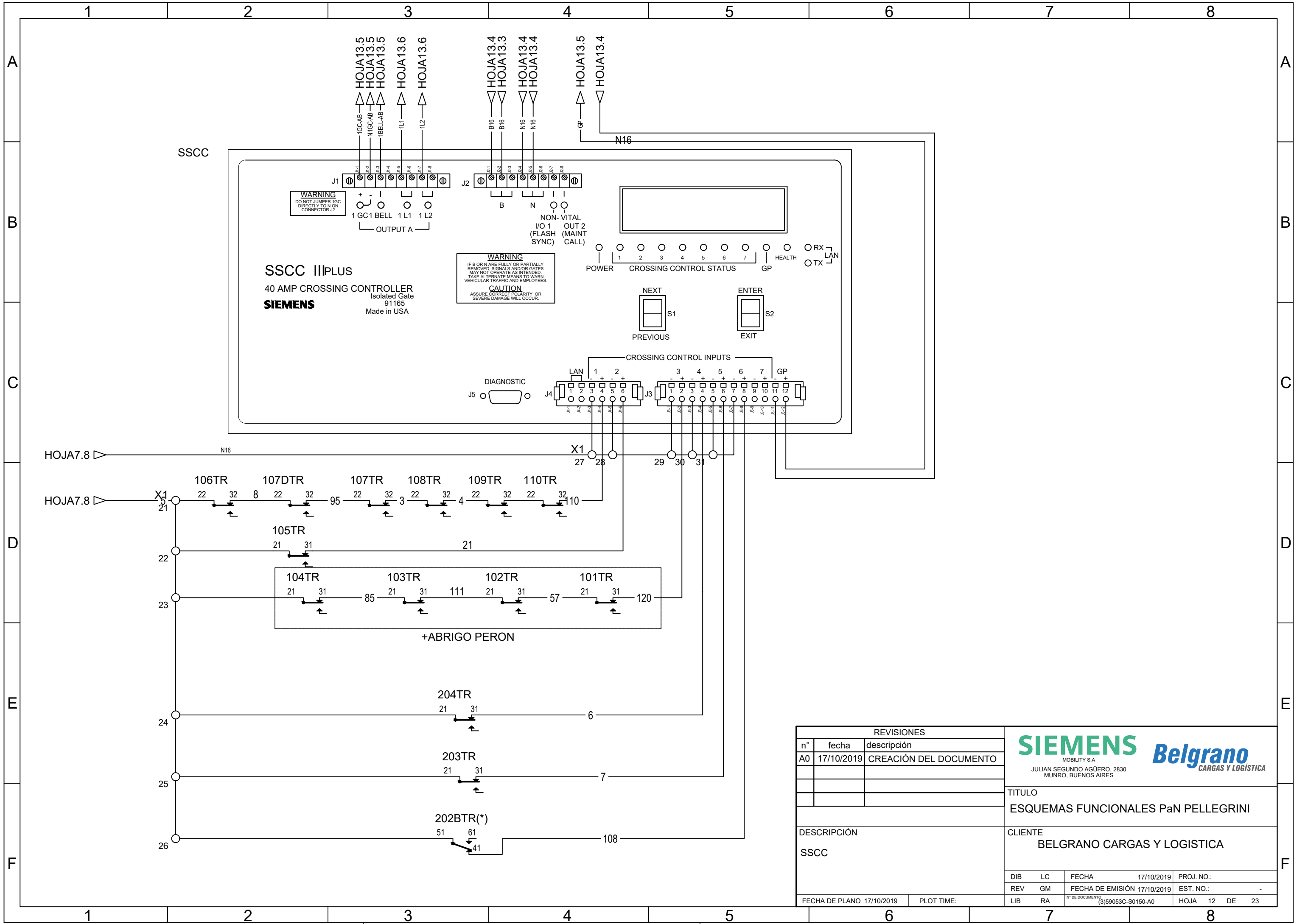

WARNING
DO NOT JUMPER IGC DIRECTLY TO N ON CONNECTOR J2

SSCC IIPLUS
40 AMP CROSSING CONTROLLER
Isolated Gate
91165
SIEMENS
Made in USA

WARNING
IF B OR N ARE FULLY OR PARTIALLY REMOVED, SIGNALS AND/OR GATES MAY NOT OPERATE AS INTENDED. TAKE ALTERNATE MEANS TO WARN VEHICULAR TRAFFIC AND EMPLOYEES.
CAUTION
ASSURE CORRECT POLARITY OR SEVERE DAMAGE WILL OCCUR.

| REVISIONES | | | |
|---------------------------|------------|------------------------|--|
| n° | fecha | descripción | |
| A0 | 17/10/2019 | CREACIÓN DEL DOCUMENTO | |
| | | | |
| | | | |
| | | | |
| FECHA DE PLANO 17/10/2019 | | PLOT TIME: | |

SIEMENS *Belgrano*
MOBILITY S.A.
JULIAN SEGUNDO AGÜERO, 2830
MUNRO, BUENOS AIRES

TITULO
ESQUEMAS FUNCIONALES PaN PELLEGRINI

DESCRIPCIÓN
SSCC

CLIENTE
BELGRANO CARGAS Y LOGISTICA

| | | | | | |
|-----|----|------------------|--------------------|------------|----------|
| DIB | LC | FECHA | 17/10/2019 | PROJ. NO.: | |
| REV | GM | FECHA DE EMISIÓN | 17/10/2019 | EST. NO.: | - |
| LIB | RA | N° DE DOCUMENTO | (3)59053C-S0150-A0 | HOJA | 12 DE 23 |

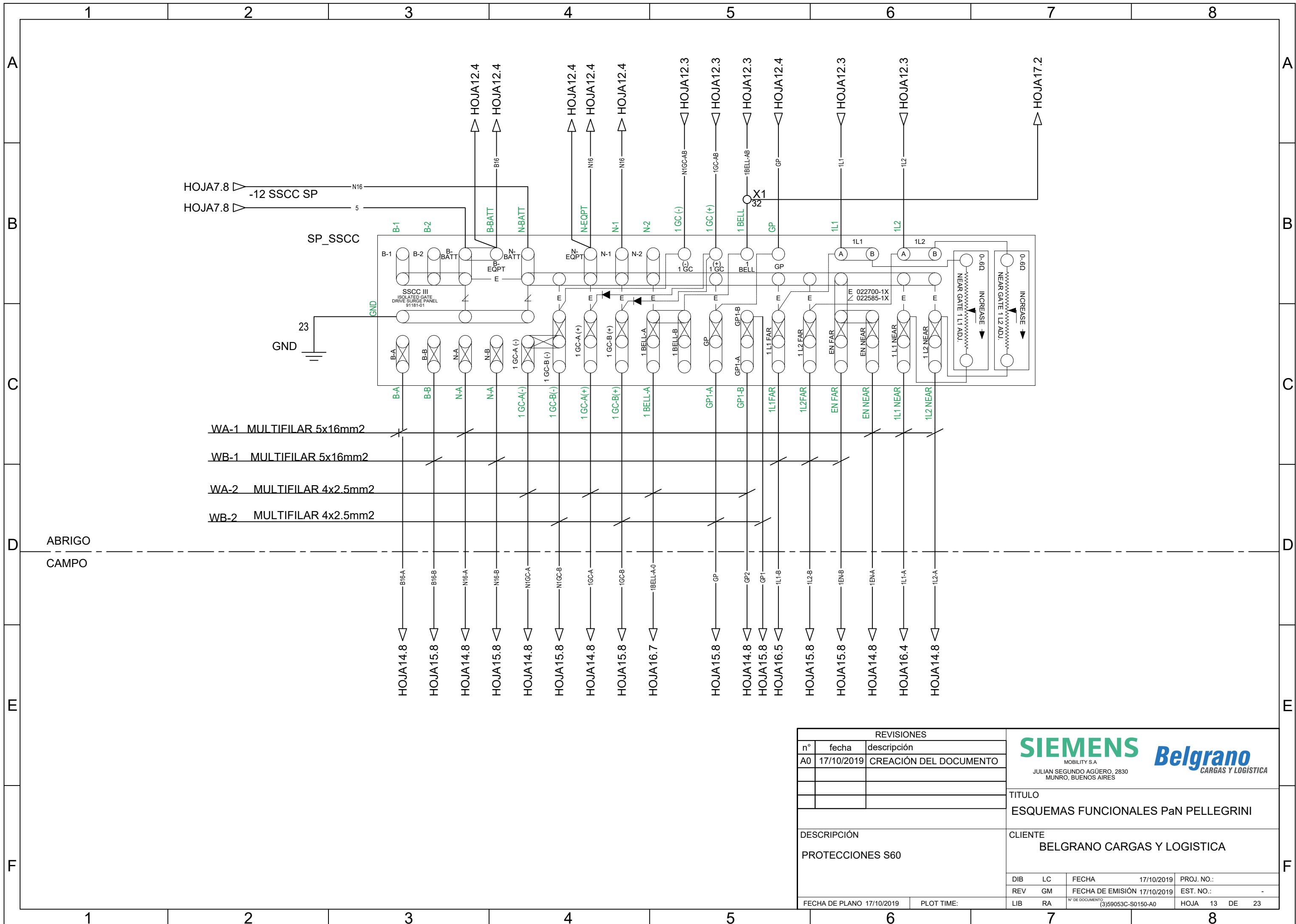

| REVISIONES | | |
|------------------|------------|------------------------|
| n° | fecha | descripción |
| A0 | 17/10/2019 | CREACIÓN DEL DOCUMENTO |
| | | |
| | | |
| | | |
| DESCRIPCIÓN | | |
| PROTECCIONES S60 | | |
| FECHA DE PLANO | 17/10/2019 | PLOT TIME: |

SIEMENS Belgrano
 MOBILITY S.A.
 JULIAN SEGUNDO AGÜERO, 2830
 MUNRO, BUENOS AIRES

TITULO
ESQUEMAS FUNCIONALES PaN PELLEGRINI

CLIENTE
BELGRANO CARGAS Y LOGISTICA

| | | | | | |
|-----|----|------------------|--------------------|------------|----------|
| DIB | LC | FECHA | 17/10/2019 | PROJ. NO.: | |
| REV | GM | FECHA DE EMISIÓN | 17/10/2019 | EST. NO.: | - |
| LIB | RA | N° DE DOCUMENTO | (3)59053C-S0150-A0 | HOJA | 13 DE 23 |

1 2 3 4 5 6 7 8

A
B
C
D
E
F

| ACCIONAMIENTO DE BARRERA "S60" | | |
|--------------------------------|---------------------|---------------------------|
| CONTACTO | CONTACTO CERRADO EN | FUNCIÓN DEL CONTACTO |
| 6 | 70°-90° | CONTROL DE ENERGIA(BAJAR) |
| 7 | 0°-89° | CONTROL DE ENERGIA(SUBIR) |
| 8 | 83°-90° | CONTROL DEL DESTELLADOR |
| 9 | 5°-90° | CONTROL DE CAMPANA |
| 10 | 0°-5° | INDICACIÓN DE BRAZO BAJO |
| 11 | | RESERVA |
| 12 | | RESERVA |

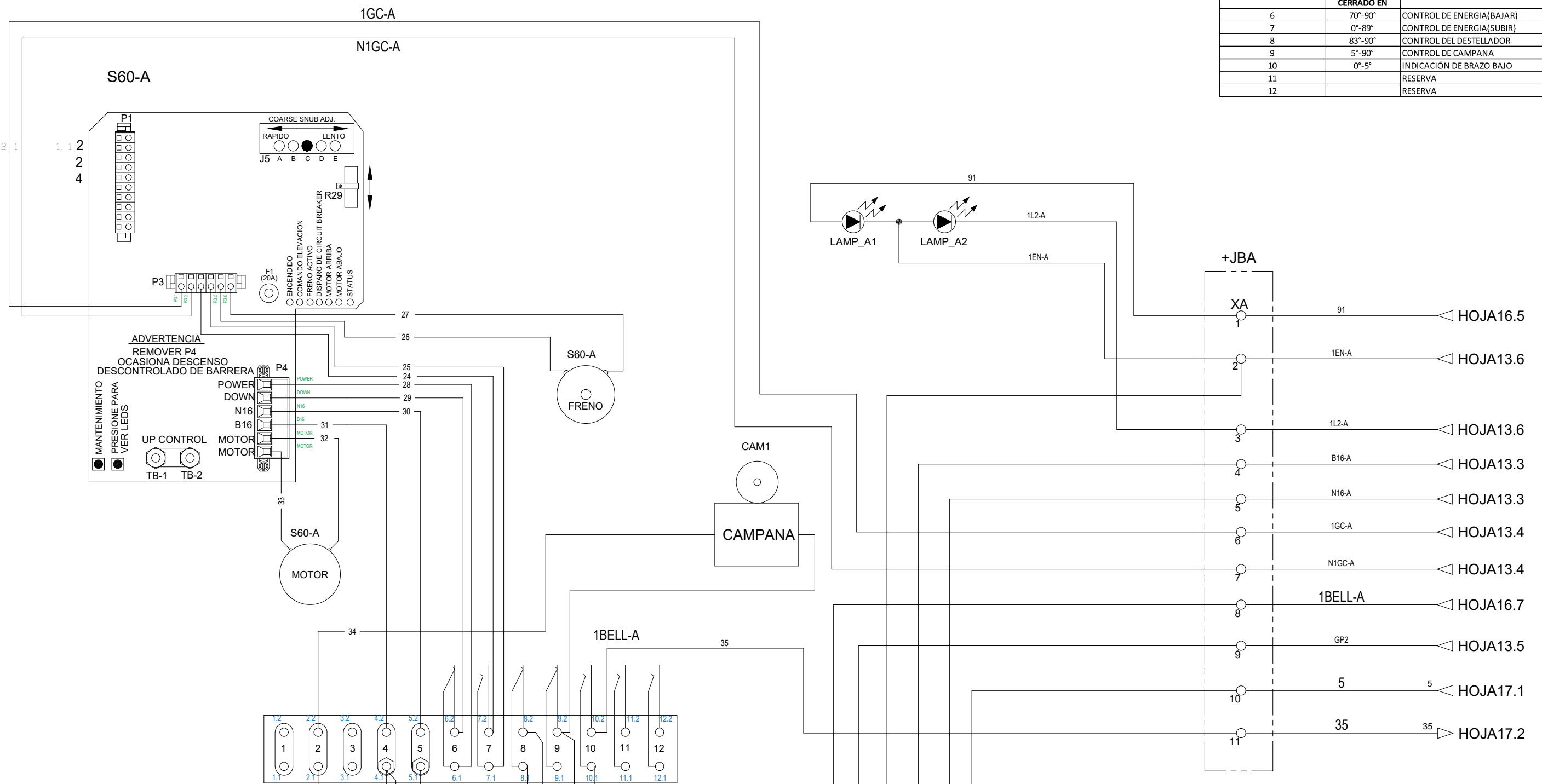

ADVERTENCIA
 REMOVER P4
 OCASIONA DESCENSO
 DESCONTROLADO DE BARRERA

MANTENIMIENTO
 PRESIONE PARA
 VER LEDS

UP CONTROL
 TB-1 TB-2

POWER DOWN
 N16
 B16
 MOTOR
 MOTOR

| REVISIONES | | |
|------------|------------|------------------------|
| n° | fecha | descripción |
| A0 | 17/10/2019 | CREACIÓN DEL DOCUMENTO |
| | | |
| | | |

FECHA DE PLANO 17/10/2019 PLOT TIME:

SIEMENS Belgrano
 MOBILITY S.A
 JULIAN SEGUNDO AGÜERO, 2830
 MUNRO, BUENOS AIRES

TITULO
ESQUEMAS FUNCIONALES PaN PELLEGRINI

CLIENTE
BELGRANO CARGAS Y LOGISTICA

| | | | | | |
|-----|----|------------------|--------------------|------------|----------|
| DIB | LC | FECHA | 17/10/2019 | PROJ. NO.: | |
| REV | GM | FECHA DE EMISIÓN | 17/10/2019 | EST. NO.: | - |
| LIB | RA | N° DE DOCUMENTO | (3)59053C-S0150-A0 | HOJA | 14 DE 23 |

1 2 3 4 5 6 7 8

1 2 3 4 5 6 7 8

A
B
C
D
E
F

| ACCIONAMIENTO DE BARRERA "S60" | | |
|--------------------------------|---------------------|---------------------------|
| CONTACTO | CONTACTO CERRADO EN | FUNCIÓN DEL CONTACTO |
| 6 | 70°-90° | CONTROL DE ENERGIA(BAJAR) |
| 7 | 0°-89° | CONTROL DE ENERGIA(SUBIR) |
| 8 | 83°-90° | CONTROL DEL DESTELLADOR |
| 9 | 5°-90° | CONTROL DE CAMPANA |
| 10 | 0°-5° | INDICACIÓN DE BRAZO BAJO |
| 11 | | RESERVA |
| 12 | | RESERVA |

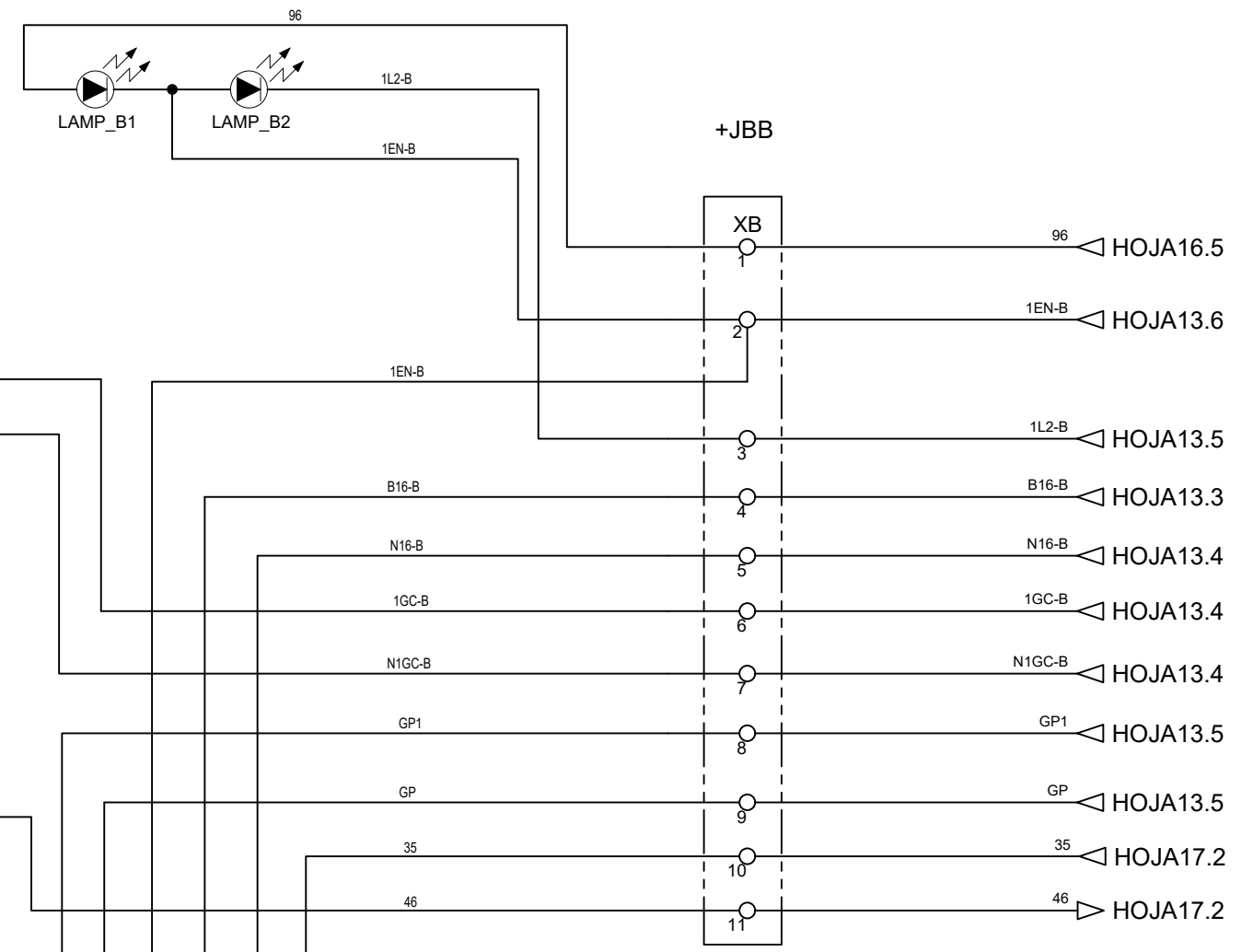
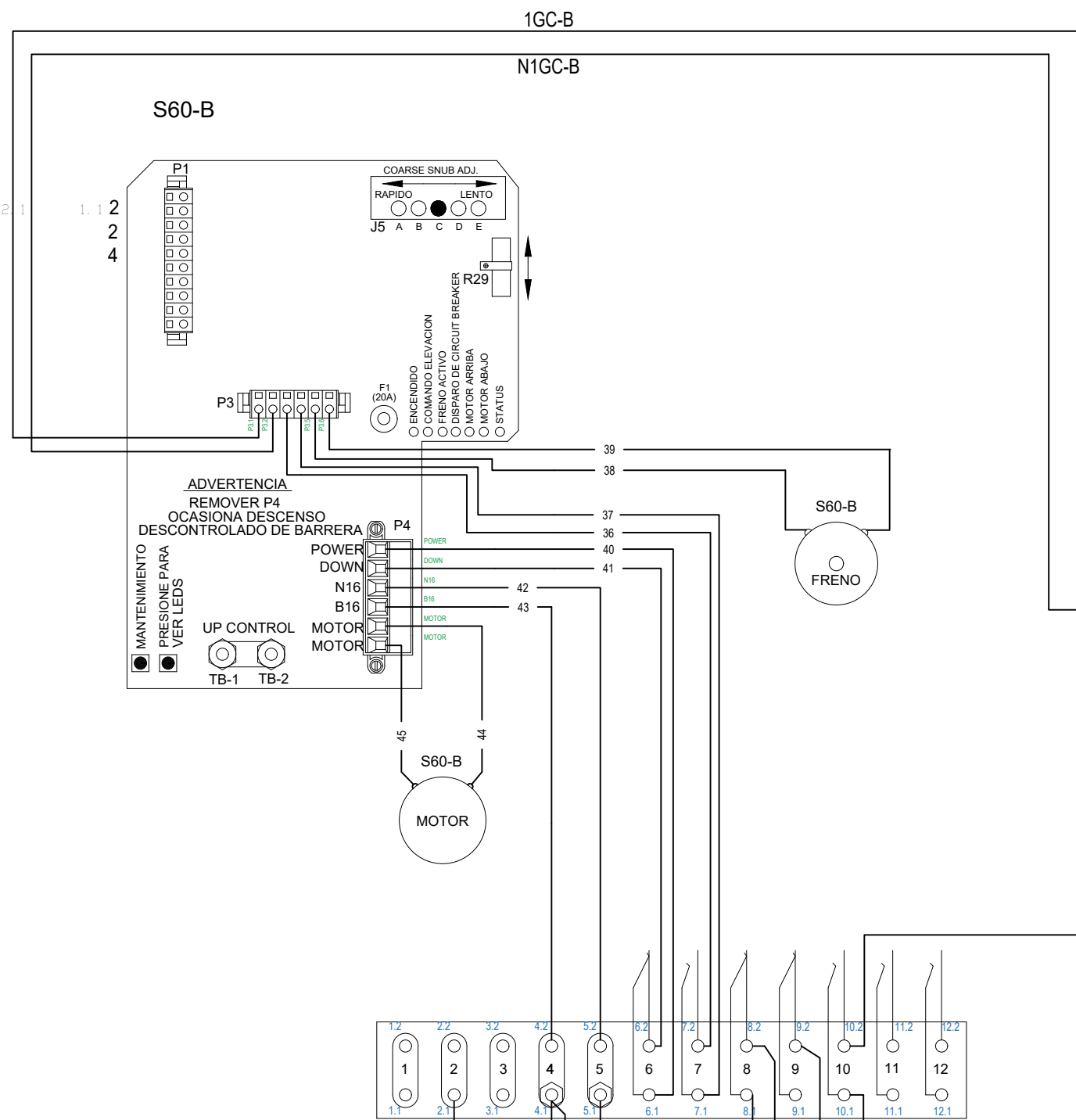

ADVERTENCIA
 REMOVER P4
 OCASIONA DESCENSO
 DESCONTROLADO DE BARRERA

MANTENIMIENTO
 PRESIONE PARA
 VER LEDS

UP CONTROL
 TB-1 TB-2

POWER DOWN
 N16
 B16
 MOTOR
 MOTOR

| REVISIONES | | |
|------------|------------|------------------------|
| n° | fecha | descripción |
| A0 | 17/10/2019 | CREACIÓN DEL DOCUMENTO |
| | | |
| | | |
| | | |

SIEMENS Belgrano
 MOBILITY S.A.
 JULIAN SEGUNDO AGÜERO, 2830
 MUNRO, BUENOS AIRES

TITULO
ESQUEMAS FUNCIONALES PaN PELLEGRINI

CLIENTE
BELGRANO CARGAS Y LOGISTICA

| | | | | | |
|-----|----|------------------|--------------------|------------|----------|
| DIB | LC | FECHA | 17/10/2019 | PROJ. NO.: | |
| REV | GM | FECHA DE EMISIÓN | 17/10/2019 | EST. NO.: | - |
| LIB | RA | N° DE DOCUMENTO | (3)59053C-S0150-A0 | HOJA | 15 DE 23 |

1 2 3 4 5 6 7 8

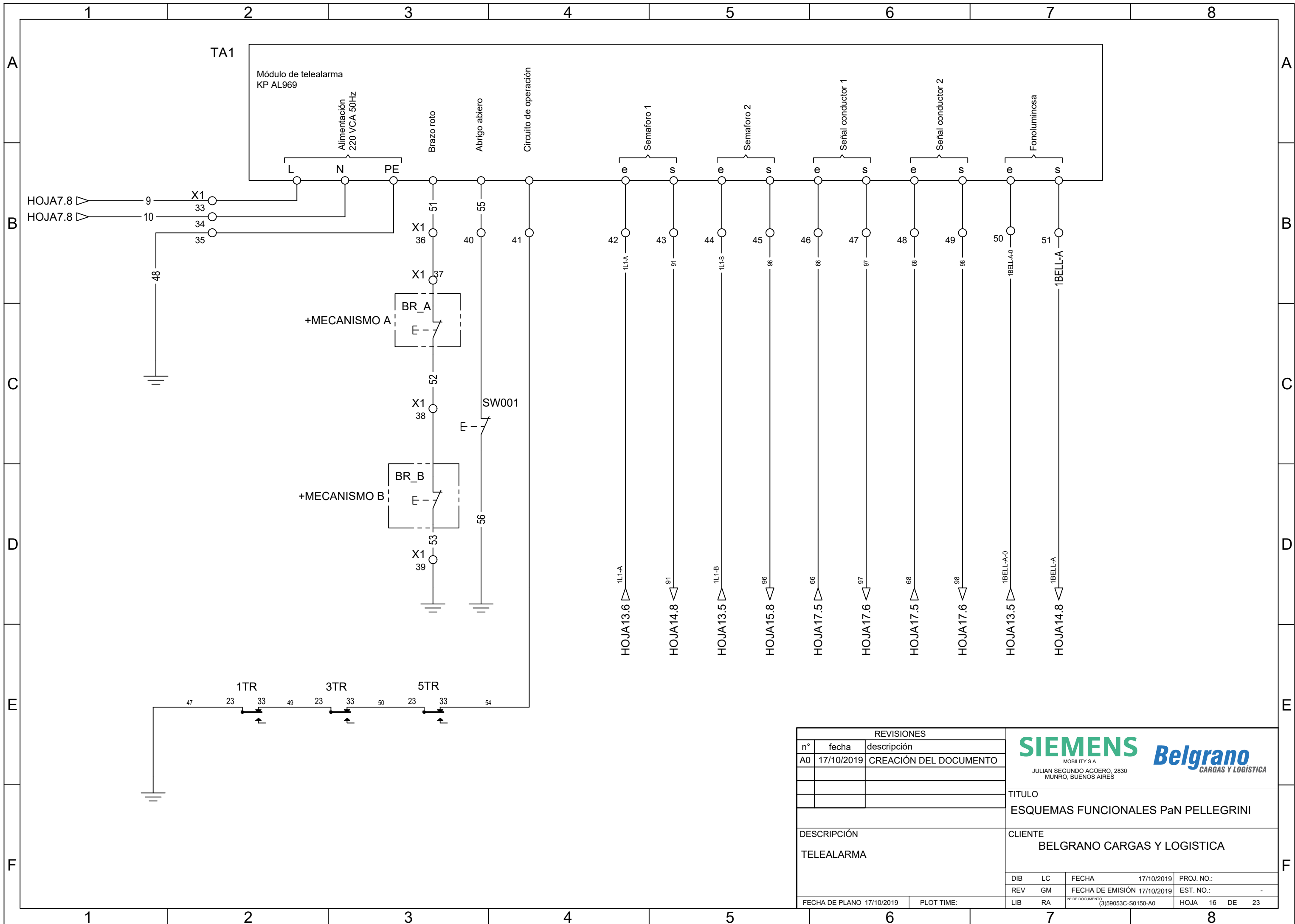

| REVISIONES | | |
|----------------|------------|------------------------|
| n° | fecha | descripción |
| A0 | 17/10/2019 | CREACIÓN DEL DOCUMENTO |
| | | |
| | | |
| | | |
| DESCRIPCIÓN | | |
| TELEALARMA | | |
| FECHA DE PLANO | 17/10/2019 | PLOT TIME: |

SIEMENS *Belgrano*
 MOBILITY S.A.
 JULIAN SEGUNDO AGÜERO, 2830
 MUNRO, BUENOS AIRES

TITULO
ESQUEMAS FUNCIONALES PaN PELLEGRINI

CLIENTE
BELGRANO CARGAS Y LOGISTICA

| | | | | | |
|-----|----|------------------|--------------------|------------|----------|
| DIB | LC | FECHA | 17/10/2019 | PROJ. NO.: | |
| REV | GM | FECHA DE EMISIÓN | 17/10/2019 | EST. NO.: | - |
| LIB | RA | N° DE DOCUMENTO | (3)59053C-S0150-A0 | HOJA | 16 DE 23 |

Listado de componentes y cantidades

| COMPONENTE | CANTIDAD | CATALOGO | DESCRIPCIÓN |
|---|----------|-----------------|-------------|
| 202BTR(*) BELLR1 | 2 | 400000 | |
| F01 | 1 | 400700-7X | |
| 104TR 105TR 106TR 107DTR 107TR 203TR 204TR | 7 | 400010 | |
| TRACK SP1 TRACK SP2 | 2 | 8000-80026-0035 | |
| SP_SSCC | 1 | 9000-91170-0001 | |
| SSCC | 1 | 9000-91190-1101 | |
| PS01 PS02 | 2 | 4000-44350-006X | |
| RA1.2 RA2.2 RA3.2 RA4.2 RA5.2 RA6.2 RA7.2 | 7 | 029603-2X | |
| R7.1 RA1.1 RA2.1 RA3.1 RA4.1 RA5.1 RA6.1 RA7.1 | 8 | 029603-9X | |

| REVISIONES | | | |
|------------|------------|------------------------|--|
| n° | fecha | descripción | |
| A0 | 17/10/2019 | CREACIÓN DEL DOCUMENTO | |
| | | | |
| | | | |



MOBILITY S.A.
JULIAN SEGUNDO AGÜERO, 2830
MUNRO, BUENOS AIRES

TITULO
ESQUEMAS FUNCIONALES PaN PELLEGRINI

CLIENTE
BELGRANO CARGAS Y LOGISTICA

| | | | | | |
|-----|----|------------------|--------------------|------------|----------|
| DIB | LC | FECHA | 17/10/2019 | PROJ. NO.: | |
| REV | GM | FECHA DE EMISIÓN | 17/10/2019 | EST. NO.: | - |
| LIB | RA | N° DE DOCUMENTO | (3)59053C-S0150-A0 | HOJA | 19 DE 23 |

FECHA DE PLANO 17/10/2019 PLOT TIME:

Listado de cables y tipos

| # multiconductor | tipo |
|------------------|-------------------------|
| W100 | Multiconductor 2 X 6mm2 |
| W200 | Multiconductor 2 X 6mm2 |
| W300 | Multiconductor 2 X 6mm2 |
| W400 | Multiconductor 2 X 6mm2 |
| W500 | Multiconductor 2 X 6mm2 |
| W600 | Multiconductor 2 X 6mm2 |
| W700 | Multiconductor 2 X 6mm2 |
| WA-1 | MULTIFILAR 5x16mm2 |
| WA-2 | MULTIFILAR 4x2.5mm2 |
| WB-1 | MULTIFILAR 5x16mm2 |
| WB-2 | MULTIFILAR 4x2.5mm2 |
| WSC1 | Multifilar 2 x 2.5mm2 |
| WSC2 | Multifilar 2 x 2.5mm2 |

| REVISIONES | | | |
|---|------------|-------------------------------------|--------------------|
| n° | fecha | descripción | |
| A0 | 17/10/2019 | CREACIÓN DEL DOCUMENTO | |
| | | | |
| | | | |
| | | | |
| DESCRIPCIÓN | | | |
| LISTADO DE CABLES Y TIPO | | | |
| FECHA DE PLANO 17/10/2019 | | | PLOT TIME: |
|  <small>MOBILITY S.A. JULIAN SEGUNDO AGÜERO, 2830 MUNRO, BUENOS AIRES</small> | | TITULO | |
| | | ESQUEMAS FUNCIONALES PaN PELLEGRINI | |
| CLIENTE | | BELGRANO CARGAS Y LOGISTICA | |
| DIB | LC | FECHA | 17/10/2019 |
| REV | GM | FECHA DE EMISIÓN | 17/10/2019 |
| LIB | RA | N° DE DOCUMENTO | (3)59053C-S0150-A0 |
| | | PROJ. NO.: | |
| | | EST. NO.: | - |
| | | HOJA | 20 DE 23 |

LISTADO DE CABLES DESDE HASTA

| #CABLE | COMPONENTE 1 | PIN1 | COMPONENTE 2 | PIN2 |
|--------|------------------|----------|--------------|----------|
| 1 | X1 | 1 | T03 | |
| 1 | X1 | 1 | T01 | |
| 1 | BELL-A TA1 | | X1 | 51 |
| 1 | BELL-A-0 TA1 | | X1 | 50 |
| 1 | BELL-A-0 SP_SSCC | 1 BELL-A | X1 | 50 |
| 1 | BELL-AB X1 | 32 | X1 | 54 |
| 1 | BELL-AB X1 | 32 | SP_SSCC | 1 BELL |
| 1 | BELL-AB X1 | 54 | BELLR1 | 3E |
| 1 | BELL-AB X1 | 54 | BELLR1 | 22 |
| 1 | BELL-AB SSCC | J1-3 | X1 | 32 |
| 1 | GC-AB SSCC | J1-1 | SP_SSCC | 1 GC (+) |
| 1 | L1 SSCC | J1-5 | SP_SSCC | 1L1 |
| 1 | L1-A TA1 | | X1 | 42 |
| 1 | L1-A SP_SSCC | 1L1 NEAR | X1 | 42 |
| 1 | L1-B TA1 | | X1 | 44 |
| 1 | L1-B SP_SSCC | 1L1FAR | X1 | 44 |
| 1 | L2 SSCC | J1-7 | SP_SSCC | 1L2 |
| 2 | X1 | 4 | T03 | |
| 2 | X1 | 4 | T01 | |
| 3 | T01 | | X1 | 2 |
| 3 | X1 | 2 | CB1 | L |
| 4 | CB1 | + | X1 | 3 |
| 4 | X1 | 3 | BT1 | |
| 5 | BT1 | | X1 | 6 |
| 5 | CB1 | - | X1 | 7 |
| 5 | CB1 | - | X1 | 6 |
| 5 | X1 | 7 | X1 | 21 |
| 5 | X1 | 7 | X1 | 8 |
| 5 | X1 | 8 | SP_SSCC | |
| 5 | X1 | 8 | X1 | 9 |
| 5 | X1 | 9 | X1 | 52 |
| 5 | X1 | 9 | X1 | 10 |
| 5 | X1 | 10 | X1 | 19 |
| 5 | X1 | 10 | X1 | 11 |
| 5 | X1 | 11 | X1 | 55 |
| 5 | X1 | 19 | PS01 | |
| 5 | X1 | 19 | PS02 | |
| 5 | X1 | 21 | 106TR | 22 |
| 5 | X1 | 21 | X1 | 22 |
| 5 | X1 | 22 | 105TR | 21 |
| 5 | X1 | 22 | X1 | 23 |
| 5 | X1 | 23 | X1 | 24 |
| 5 | X1 | 24 | 204TR | 21 |
| 5 | X1 | 24 | X1 | 25 |
| 5 | X1 | 25 | 203TR | 21 |
| 5 | X1 | 25 | X1 | 26 |
| 5 | X1 | 26 | 202BTR(*) | 51 |
| 5 | X1 | 52 | F01 | |
| 6 | 204TR | 31 | SSCC | J3-4 |
| 7 | PS01 | | 107TR | 1E |

| #CABLE | COMPONENTE 1 | PIN1 | COMPONENTE 2 | PIN2 |
|--------|--------------|------|--------------|------|
| 7 | 107TR | 1E | TRACK SP1 | |
| 7 | 203TR | 31 | SSCC | J3-6 |
| 8 | 106TR | 32 | 107DTR | 22 |
| 9 | T03 | | X1 | 17 |
| 9 | X1 | 17 | X1 | 33 |
| 9 | X1 | 33 | TA1 | |
| 10 | T03 | | X1 | 18 |
| 10 | X1 | 18 | X1 | 34 |
| 10 | X1 | 34 | TA1 | |
| 21 | 105TR | 31 | SSCC | J4-6 |
| 46 | F01 | | X1 | 53 |
| 47 | | | 1TR | 23 |
| 48 | | | X1 | 35 |
| 48 | X1 | 35 | TA1 | |
| 49 | 1TR | 33 | 3TR | 23 |
| 50 | 3TR | 33 | 5TR | 23 |
| 51 | TA1 | | X1 | 36 |
| 51 | X1 | 36 | X1 | 37 |
| 53 | X1 | 39 | | |
| 54 | TA1 | | X1 | 41 |
| 54 | 5TR | 33 | X1 | 41 |
| 55 | TA1 | | X1 | 40 |
| 55 | X1 | 40 | SW001 | |
| 56 | SW001 | | | |
| 60 | 204TR | 32 | 202BTR(*) | 21 |
| 61 | BELLR1 | 32 | F01 | 3E |
| 64 | 1TR | 41 | BELLR1 | 21 |
| 65 | 5TR | 41 | BELLR1 | 23 |
| 66 | TA1 | | X1 | 46 |
| 66 | BELLR1 | 31 | X1 | 46 |
| 68 | TA1 | | X1 | 48 |
| 68 | BELLR1 | 33 | X1 | 48 |
| 70 | 202BTR(*) | 31 | 202BTR(*) | 1E |
| 74 | 107DTR | 1E | TRACK SP1 | |
| 75 | PS01 | | 106TR | 1E |
| 75 | 106TR | 1E | TRACK SP1 | |
| 76 | PS01 | | 105TR | 1E |
| 76 | 105TR | 1E | TRACK SP1 | |
| 77 | PS02 | | 104TR | 1E |
| 77 | 104TR | 1E | TRACK SP2 | |
| 84 | PS02 | | PS02 | |
| 84 | PS02 | | 204TR | 1E |
| 84 | 204TR | 1E | TRACK SP2 | |
| 86 | PS02 | | 203TR | 1E |
| 86 | 203TR | 1E | TRACK SP2 | |
| 87 | PS01 | | RA1.1 | |
| 91 | TA1 | | X1 | 43 |
| 93 | PS01 | | RA2.1 | |
| 94 | PS01 | | RA3.1 | |
| 95 | 107DTR | 32 | 107TR | 22 |

| REVISIONES | | |
|-------------------|------------|------------------------|
| n° | fecha | descripción |
| A0 | 17/10/2019 | CREACIÓN DEL DOCUMENTO |
| | | |
| | | |
| | | |
| DESCRIPCIÓN | | |
| LISTA DESDE HASTA | | |
| FECHA DE PLANO | 17/10/2019 | PLOT TIME: |



| | | | |
|-------------------------------------|-----------|------------------|--------------------|
| TITULO | | | |
| ESQUEMAS FUNCIONALES PaN PELLEGRINI | | | |
| CLIENTE | | | |
| BELGRANO CARGAS Y LOGISTICA | | | |
| DIB | LC | FECHA | 17/10/2019 |
| REV | GM | FECHA DE EMISIÓN | 17/10/2019 |
| LIB | RA | N° DE DOCUMENTO | (3)59053C-S0150-A0 |
| PROJ. NO.: | EST. NO.: | HOJA | 21 DE 23 |

LISTADO DE CABLES DESDE HASTA

| #CABLE | COMPONENTE 1 | PIN1 | COMPONENTE 2 | PIN2 |
|---------|--------------|--------|--------------|----------|
| 96 | TA1 | | X1 | 45 |
| 97 | TA1 | | X1 | 47 |
| 97 | X1 | 47 | X1 | 57 |
| 98 | TA1 | | X1 | 49 |
| 98 | X1 | 49 | X1 | 59 |
| 99 | PS01 | | RA4.1 | |
| 100 | PS02 | | RA5.1 | |
| 101 | PS02 | | RA6.1 | |
| 102 | PS02 | | RA7.1 | |
| 103 | PS02 | | R7.1 | |
| 104 | RA1.1 | | RA1.2 | |
| 104 | RA1.2 | | TRACK SP1 | |
| 108 | 202BTR(*) | 41 | SSCC | J3-8 |
| 109 | RA2.1 | | RA3.1 | |
| 109 | RA3.1 | | RA4.1 | |
| 109 | RA4.1 | | RA2.2 | |
| 109 | RA2.2 | | RA3.2 | |
| 109 | RA3.2 | | RA4.2 | |
| 109 | RA4.2 | | TRACK SP1 | |
| 109 | TRACK SP1 | | TRACK SP1 | |
| 109 | TRACK SP1 | | TRACK SP1 | |
| 112 | RA7.1 | | RA7.2 | |
| 112 | RA7.2 | | TRACK SP2 | |
| 112 | RA6.1 | | R7.1 | |
| 112 | R7.1 | | RA6.2 | |
| 112 | RA6.2 | | TRACK SP2 | |
| 112 | RA5.1 | | RA5.2 | |
| 112 | RA5.2 | | TRACK SP2 | |
| 113 | 107TR | 3E | RA1.2 | |
| 114 | 104TR | 3E | RA5.2 | |
| 115 | 107DTR | 3E | RA2.2 | |
| 116 | 204TR | 3E | RA6.2 | |
| 117 | 106TR | 3E | RA3.2 | |
| 118 | 203TR | 3E | RA7.2 | |
| 119 | 105TR | 3E | RA4.2 | |
| B16 | SP_SSCC | B-BATT | SSCC | J2-2 |
| B16 | SP_SSCC | B-BATT | SSCC | J2-1 |
| GP | SSCC | J3-12 | SP_SSCC | GP |
| N1GC-AB | SSCC | J1-2 | SP_SSCC | 1 GC (-) |
| N16 | T01 | | X1 | 5 |
| N16 | F01 | 1E | X1 | 56 |
| N16 | BELLR1 | 1E | X1 | 56 |
| N16 | X1 | 5 | CB1 | N |
| N16 | X1 | 12 | X1 | 20 |
| N16 | X1 | 12 | X1 | 13 |
| N16 | X1 | 12 | 202BTR(*) | 3E |
| N16 | X1 | 13 | X1 | 27 |
| N16 | X1 | 13 | X1 | 14 |
| N16 | X1 | 14 | SP_SSCC | N-BATT |
| N16 | X1 | 14 | X1 | 15 |

| #CABLE | COMPONENTE 1 | PIN1 | COMPONENTE 2 | PIN2 |
|--------|--------------|--------|--------------|-------|
| N16 | X1 | 15 | X1 | 56 |
| N16 | X1 | 15 | X1 | 16 |
| N16 | X1 | 16 | X1 | 60 |
| N16 | X1 | 20 | PS01 | |
| N16 | X1 | 20 | PS02 | |
| N16 | X1 | 27 | X1 | 28 |
| N16 | X1 | 28 | X1 | 29 |
| N16 | X1 | 29 | X1 | 30 |
| N16 | X1 | 30 | X1 | 31 |
| N16 | X1 | 31 | SSCC | J3-7 |
| N16 | X1 | 58 | X1 | 60 |
| N16 | SSCC | J3-1 | X1 | 29 |
| N16 | SSCC | J3-3 | X1 | 30 |
| N16 | SSCC | J3-5 | X1 | 31 |
| N16 | SSCC | J4-3 | X1 | 27 |
| N16 | SSCC | J4-5 | X1 | 28 |
| N16 | CB1 | N | X1 | 12 |
| N16 | SP_SSCC | N-1 | SSCC | J3-11 |
| N16 | SP_SSCC | N-EQPT | SSCC | J2-5 |
| N16 | SP_SSCC | N-EQPT | SSCC | J2-4 |

| REVISIONES | | | |
|-------------|------------|------------------------|--|
| n° | fecha | descripción | |
| A0 | 17/10/2019 | CREACIÓN DEL DOCUMENTO | |
| | | | |
| | | | |
| DESCRIPCIÓN | | | |



MOBILITY S.A
JULIAN SEGUNDO AGÜERO, 2830
MUNRO, BUENOS AIRES

TITULO
ESQUEMAS FUNCIONALES PaN PELLEGRINI

CLIENTE
BELGRANO CARGAS Y LOGISTICA

| | | | | | |
|-----|----|------------------|--------------------|------------|----------|
| DIS | LC | FECHA | 17/10/2019 | PROJ. NO.: | |
| REV | GM | FECHA DE EMISIÓN | 17/10/2019 | EST. NO.: | - |
| DIB | RA | N° DE DOCUMENTO | (3)59053C-S0150-A0 | HOJA | 22 DE 23 |

FECHA DE PLANO 17/10/2019 PLOT TIME:

