

ESTRUCTURA METALICA

Construida en Hierro ángulo de 1 1/4" x 1/4" y bulones de anclaje de acero de Ø 7/8"

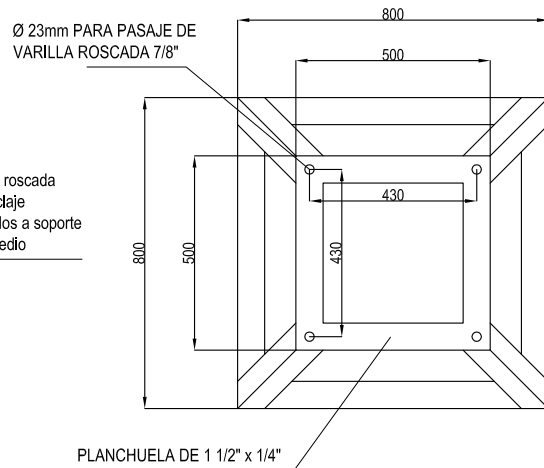

PLANTA

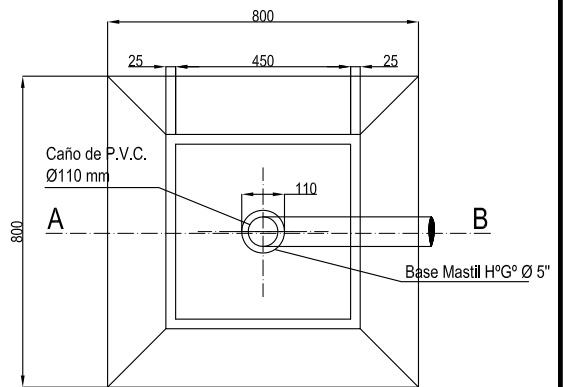

**CORTE A-B
DETALLE BASE
ENTERRADA**

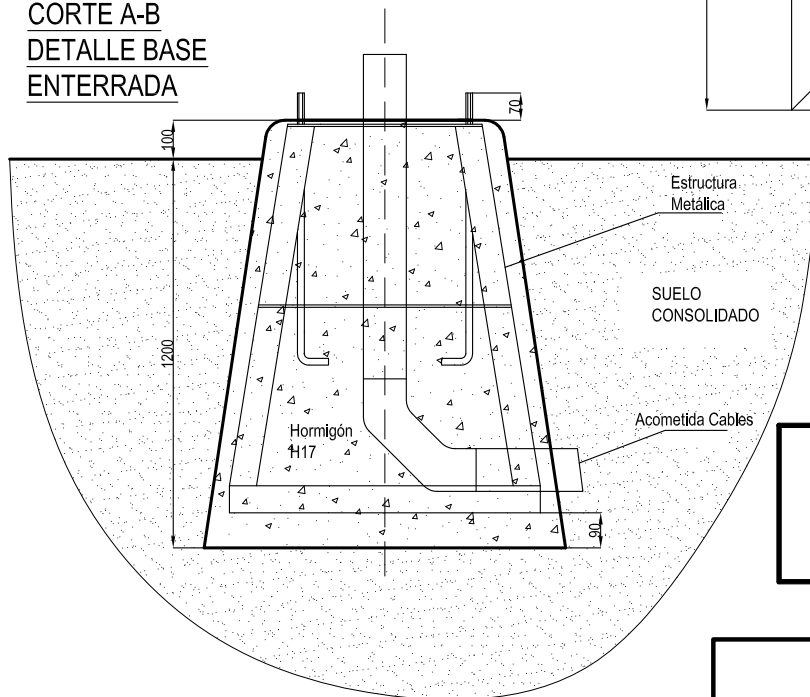

Al momento de hormigonar las varillas roscadas de 7/8" deben estar fijadas a la estructura tanto en su parte superior como inferior mediante tuerca y arandela plana

**PLANO ESQUEMÁTICO
NO APTO PARA CONSTRUCCIÓN**

		PLANO TIPO DE OBRA																		
														PROYECTÓ						
														DIBUJÓ / MODIFICÓ						
		BASE DE MASTIL DE BARRERA												REVISÓ						
														TOTAL DE HOJAS						
														1	1					
ESCALA: S/E	FECHA:	-	-	-	-	-	-	-	-	-	-	-	S	Ñ	0	0	0	0	1	0